

MAGTROL

Model DSP6001

High Speed Programmable Dynamometer Controller

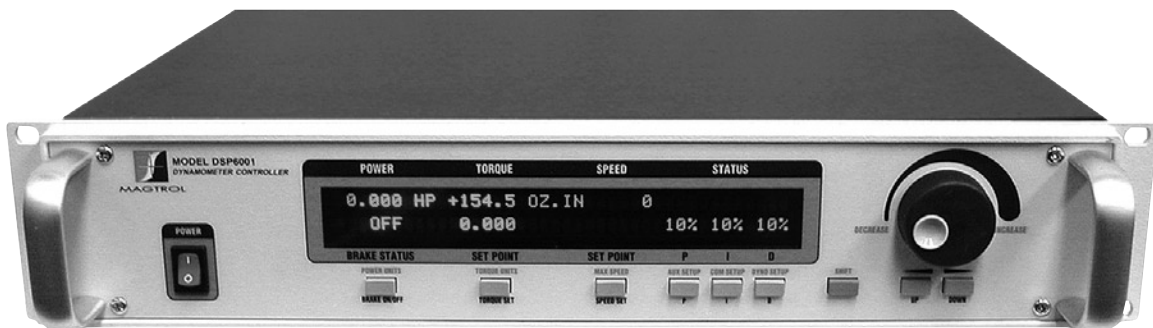

User's Manual

Purchase Record

Please record all model numbers and serial numbers of your Magtrol equipment, along with the general purchase information. The model number and serial number can be found on either a silver identification plate or white label affixed to each unit. Refer to these numbers whenever you communicate with a Magtrol representative about this equipment.

Model Number: _____

Serial Number: _____

Purchase Date: _____

Purchased From: _____

While every precaution has been exercised in the compilation of this document to ensure the accuracy of its contents, Magtrol, Inc. assumes no responsibility for errors or omissions. Additionally, no liability is assumed for any damages that may result from the use of the information contained within this publication.

COPYRIGHT

Copyright ©2001-2005 Magtrol, Inc. All rights reserved.

Copying or reproduction of all or any part of the contents of this manual without the express permission of Magtrol is strictly prohibited.

TRADEMARKS

LabVIEW™ is a trademark of National Instruments Corporation.

Microsoft® is a registered trademark of Microsoft Corporation.

National Instruments™ is a trademark of National Instruments Corporation.

Windows® is a registered trademark of Microsoft Corporation.

Safety Precautions



1. Make sure that all Magtrol dynamometers and electronic products are earth-grounded, to ensure personal safety and proper operation.
2. Check line voltage before operating the DSP6001.
3. Make sure that dynamometers and motors under test are equipped with appropriate safety guards.

Revisions To This Manual

The contents of this manual are subject to change without prior notice. Should revisions be necessary, updates to all Magtrol User's Manuals can be found at Magtrol's web site at www.magtrol.com/support/manuals.htm.

Please compare the date of this manual with the revision date on the web site, then refer to the manual's Table of Revisions for any changes/updates that have been made since this edition.

REVISION DATE

1st Edition, revision H – May 2005

TABLE OF REVISIONS

Date	Edition	Change	Section(s)
05/18/05	1st Edition - rev. H	Changed M-TEST 4.0 references to "M-TEST" or "M-TEST 5.0"	throughout manual
06/28/04	1st Edition - rev. G	Removed DSP6001 resetting procedure	9.4
05/24/04	1st Edition - rev. F	Added DIR#, OH1 and IOXX.XX Misc. Command codes	8.6.7, D.6
08/05/03	1st Edition - rev. E	Ratings changes for: Operating Temperature, Accuracy, Temperature Coefficient and Accessory Torque/Speed Output	1.3
08/05/03	1st Edition - rev. E	Auxiliary Input rating replaced with Input Voltage Range	1.3
08/05/03	1st Edition - rev. E	Screen Saver function removed	2.3.2
08/05/03	1st Edition - rev. E	Added Power Alarm to priority table	6.1.3
08/05/03	1st Edition - rev. E	Deleted DDLXX.XX Ramp Command code	8.6.3, D.3
08/05/03	1st Edition - rev. E	Deleted A,B,C,D and E Speed Command codes	8.6.3, 8.6.5, D.3
08/05/03	1st Edition - rev. E	Deleted C# Misc. Command code	8.6.7, D.6
05/06/02	1st Edition - rev. D	Speed check and decimal point check added to calibration procedure	9.3.5 & 9.3.6
12/20/01	1st Edition - rev. C	Added values for analog filter setup (AF1# and AF2#)	8.6.4
12/20/01	1st Edition - rev. C	Added filter cutoff frequency	4.1
08/27/01	1st Edition - rev. B	Changed name of chapter titles	Chap. 7 & 8
08/27/01	1st Edition - rev. B	Changed name and location of Additional Scale Factor Table	Appendix F
08/27/01	1st Edition - rev. B	Updated Power Analyzers in System Options table	1.3
07/23/01	1st Edition - rev. A	Updated Motor Testing Software section and System Options	1.3
07/23/01	1st Edition - rev. A	Increased range of PID numbers when using the multiplier	5.4
07/23/01	1st Edition - rev. A	Changed Contact Configuration and Manufacturer P/N under Relay Specifications	6.1.1
07/23/01	1st Edition - rev. A	Air Flow Alarm for Eddy-Current/Powder Brake Dynamometers is not available	6.1.3
07/23/01	1st Edition - rev. A	Changed IDN? command to *IDN? command	8.6
07/23/01	1st Edition - rev. A	Added alarm condition to explanation of OD command	8.6
07/23/01	1st Edition - rev. A	Entered exact figures for reference voltage	9.3.2, 9.3.3
07/23/01	1st Edition - rev. A	Defined accepted voltage range in steps 3, 6, 9 & 14	9.3.4
03/27/01	1st Edition	Complete re-write of Preliminary Manual	entire manual

Table of Contents

SAFETY PRECAUTIONS	I
REVISIONS TO THIS MANUAL	II
REVISION DATE.....	II
TABLE OF REVISIONS	II
TABLE OF CONTENTS	III
TABLE OF FIGURES	VII
PREFACE.....	IX
PURPOSE OF THIS MANUAL	IX
WHO SHOULD USE THIS MANUAL.....	IX
MANUAL ORGANIZATION	IX
CONVENTIONS USED IN THIS MANUAL	X
1. INTRODUCTION	1
1.1 UNPACKING YOUR DSP6001	1
1.2 NEW FEATURES OF THE DSP6001	1
1.3 DATA SHEET.....	2
2. CONTROLS.....	8
2.1 FRONT PANEL.....	8
2.2 FRONT PANEL CONTROLS AND BUTTONS	8
2.2.1 Enabling Secondary Functions.....	8
2.2.2 Enabling Saving Function	9
2.2.3 How to Use Front Panel Controls and Buttons	9
2.3 VACUUM FLUORESCENT DISPLAY (VFD).....	10
2.3.1 Contrast Settings	11
2.3.2 Screen Saver	11
2.3.3 Status Display Messages	11
2.4 REAR PANEL	12
2.5 REAR PANEL INPUTS AND OUTPUTS.....	12
3. INSTALLATION/CONFIGURATION.....	15
3.1 POWERING UP THE DSP6001	15
3.1.1 Setting Unit for Line Voltage	15
3.1.2 Self-Test	16
3.1.3 Main Menu	16
3.2 TESTING INSTRUMENTATION SETUP	17
3.2.1 Dynamometer Configuration Menu	18
3.2.2 Hysteresis Dynamometer Setup	19
3.2.3 Hysteresis Dynamometer with Torque Transducer Setup.....	20
3.2.4 Hysteresis Dynamometer with Auxiliary Instrumentation Setup.....	22
3.2.5 Hysteresis Dynamometer with Eddy-Current or Powder Brake Setup	24
3.2.6 Eddy-Current or Powder Brake Dynamometer Setup.....	26
3.2.7 Eddy-Current or Powder Brake Dynamometer with Torque Transducer Setup.....	27
3.2.8 Eddy-Current or Powder Brake Dynamometer with Auxiliary Instrumentation Setup	28
3.2.9 Two Eddy-Current/Powder Brake Dynamometers (Independent Setup).....	29
3.2.10 Two Eddy-Current/Powder Brake Dynamometers (Tandem Setup).....	31
3.2.11 Eddy-Current Dynamometer with Powder Brake Dynamometer (Tandem Setup).....	33
3.2.12 In-Line Torque Transducer Cross Loop Function	35

3.3	SPEED ENCODER SETUP.....	36
3.3.1	Bit Configurations.....	36
3.4	TORQUE/SPEED ANALOG OUTPUTS.....	37
3.4.1	Torque DAC Scale Factor.....	37
3.4.2	Speed DAC Scale Factor.....	37
3.4.3	Torque/Speed DAC Setup.....	37
4.	DIGITAL FILTERS.....	38
4.1	FILTER PARAMETERS.....	38
4.2	FILTER SETUP.....	39
5.	PID SETTINGS.....	40
5.1	ABOUT THE PID LOOP.....	40
5.1.1	P (Proportional Gain).....	40
5.1.2	I (Integral).....	40
5.1.3	D (Derivative).....	40
5.2	SETTING PID VALUES.....	40
5.2.1	How To Set P (Proportional Gain) Value.....	40
5.2.2	How to Set I (Integral) Value.....	40
5.2.3	How to Set D (Derivative) Value.....	40
5.3	HOW THE PID LOOP WORKS.....	41
5.3.1	Scale Factors for Hysteresis, Eddy-Current and Powder Brake Dynamometers.....	41
5.3.2	Speed Correction for WB (Eddy-Current Brake) Dynamometer.....	41
5.3.3	Equations.....	42
5.4	ADDITIONAL SCALE FACTOR.....	42
5.4.1	How To Set Additional Scale Factor.....	42
5.5	SETTING THE CORRECT PID'S FOR YOUR MOTOR.....	43
5.5.1	Setting the PID with an Unknown Motor or System.....	43
5.5.2	Setting the PID for Torque Control.....	43
5.5.3	Setting the PID for Speed Control.....	46
5.5.4	Setting the PID for Ramp Down.....	48
6.	ALARM SYSTEM.....	50
6.1	GENERAL INFORMATION.....	50
6.1.1	Alarm Relay.....	50
6.1.2	Alarm Operation.....	51
6.1.3	Alarm Priority.....	52
6.2	POWER ALARM.....	52
6.2.1	Instructions for Power Alarm Setup.....	52
6.2.2	Power Alarm Action.....	53
6.2.3	To Reset Power Alarm.....	53
6.3	MAXIMUM SPEED ALARM.....	53
6.3.1	Instructions for Maximum Speed Alarm Setup.....	53
6.3.2	Maximum Speed Alarm Action.....	54
6.3.3	To Reset Maximum Speed Alarm.....	54
6.4	MAXIMUM TORQUE ALARM.....	54
6.4.1	Instructions for Maximum Torque Alarm Setup.....	54
6.4.2	Maximum Torque Alarm Action.....	55
6.4.3	To Reset Maximum Torque Alarm.....	55
6.5	AIR FLOW ALARM.....	56
6.5.1	Instructions for Air Flow Alarm Setup.....	56
6.5.2	Air Flow Alarm Action.....	56
6.5.3	To Reset Air Flow Alarm.....	56

6.6	WATER FLOW ALARM	57
6.6.1	Instructions for Water Flow Alarm Setup.....	57
6.6.2	Water Flow Alarm Action	57
6.6.3	To Reset Water Flow Alarm	57
6.7	EXTERNAL ALARM	58
6.7.1	Instructions for External Alarm Setup.....	58
6.7.2	External Alarm Action.....	58
6.7.3	To Reset External Alarm	58
6.8	TEMPERATURE ALARM	59
6.8.1	Instructions for Temperature Alarm Setup.....	59
6.8.2	Temperature Alarm Action.....	59
6.8.3	To Reset Temperature Alarm.....	59
6.9	ELECTRICAL ALARM	60
6.9.1	Instructions for Electrical Alarm Setup.....	60
6.9.2	Electrical Alarm Action.....	60
6.9.3	To Reset Electrical Alarm	60
7.	MANUALLY CONTROLLED OPERATION	61
7.1	HOW TO CHOOSE DESIRED CHANNEL WHEN USING TWO DYNAMOMETERS	61
7.2	HOW TO SET DESIRED POWER UNITS	62
7.3	HOW TO SET DESIRED TORQUE UNITS	62
7.4	HOW TO SET TORQUE CONTROL.....	62
7.5	HOW TO SET SPEED CONTROL	63
7.6	HOW TO SET OPEN LOOP CONTROL.....	64
8.	COMPUTER CONTROLLED OPERATION	65
8.1	ABOUT THE GPIB INTERFACE	65
8.1.1	Installing the GPIB (IEEE-488) Connector Cable.....	65
8.1.2	Changing the GPIB Primary Address	66
8.2	ABOUT THE RS-232 INTERFACE.....	66
8.2.1	Connection	66
8.2.2	Communication Parameters	67
8.2.3	Baud Rate	67
8.3	CHECKING THE DSP6001-TO-PC CONNECTION.....	67
8.4	DATA FORMAT	68
8.5	PROGRAMMING	68
8.5.1	Data Termination Characters.....	68
8.5.2	Timeout	69
8.6	DSP6001 COMMAND SET	69
8.6.1	Alarm Commands	69
8.6.2	Communication Commands.....	70
8.6.3	Ramp Commands.....	71
8.6.4	Setup Commands	72
8.6.5	Speed Commands.....	74
8.6.6	Torque Commands	74
8.6.7	Miscellaneous Command.....	75
9.	CALIBRATION	76
9.1	CLOSED-BOX CALIBRATION	76
9.2	CALIBRATION SCHEDULE.....	76
9.3	BASIC CALIBRATION PROCESS.....	76
9.3.1	Initial Calibration Procedure	76

9.3.2	TSC1 Offset and Gain	77
9.3.3	TSC2 Offset and Gain	78
9.3.4	DAC Output Offset and Gain	78
9.3.5	Speed Check.....	80
9.3.6	Decimal Point Check.....	81
10.	TROUBLESHOOTING.....	82
APPENDIX A:	LABVIEW PROGRAMMING EXAMPLES	83
A.1	SIMPLE READ.....	83
A.2	TORQUE STABILIZED	84
A.3	SPEED STABILIZED	85
APPENDIX B:	INERTIA CORRECTION.....	86
B.1	INERTIAL EFFECT ON MOTOR TEST DATA	86
B.2	PROCEDURE FOR INERTIA CORRECTION	86
B.2.1	Key Conditions.....	87
APPENDIX C:	FRONT PANEL/DISPLAY MENU FLOW CHARTS	88
C.1	PRIMARY KEY FUNCTIONS.....	88
C.2	SECONDARY KEY FUNCTIONS	89
C.2.1	Power Units Menu.....	89
C.2.2	Torque Units Menu.....	89
C.2.3	Max Speed Menu	90
C.2.4	Aux Setup Menu	90
C.2.5	Com Setup Menu.....	91
C.2.6	Dyno Setup Menu	92
APPENDIX D:	REMOTE CONFIGURATION FLOW CHARTS.....	101
D.1	ADVANCED CONFIGURATION.....	101
D.2	PRE-TEST	102
D.3	RAMP.....	103
D.4	SPEED	104
D.5	TORQUE.....	105
D.6	MISCELLANEOUS.....	106
D.7	DATA	106
APPENDIX E:	SCHEMATICS	107
E.1	DYNAMOMETER POWER SUPPLY.....	107
E.2	DYNAMOMETER DSP & MEMORY.....	108
E.3	DSP DYNAMOMETER ANALOG I/O.....	109
APPENDIX F:	ADDITIONAL SCALE FACTOR TABLE.....	110
INDEX.....		111
MAGTROL LIMITED WARRANTY.....		114
CLAIMS		114
SERVICE INFORMATION.....		115
RETURNING MAGTROL EQUIPMENT FOR REPAIR AND/OR CALIBRATION		115
Returning Equipment to Magtrol, Inc. (United States)		115
Returning Equipment to Magtrol SA (Switzerland).....		115

TABLE OF FIGURES

2. CONTROLS

Figure 2-1 Front Panel	8
Figure 2-2 Secondary Function Menu.....	8
Figure 2-3 Saving Function Menu.....	9
Figure 2-4 Rear Panel.....	12
Figure 2-5 Dynamometer Brake Input	12
Figure 2-6 Accessory Torque-Speed Output.....	12
Figure 2-7 Dynamometer/TSC1 Connector	13
Figure 2-8 AUX/TSC2 Connector.....	13
Figure 2-9 Supply 1 Connector	13
Figure 2-10 Supply 2 Connector.....	14
Figure 2-11 RS-232C Interface	14

3. INSTALLATION/CONFIGURATION

Figure 3-1 Cover for Voltage Selector, Fuses.....	15
Figure 3-2 Program Download Display.....	16
Figure 3-3 Revision Display.....	16
Figure 3-4 Alarm Warning Display	16
Figure 3-5 Main Menu	16
Figure 3-6 Dyno Setup Menu	18
Figure 3-7 Dynamometer Configuration Menu.....	18
Figure 3-8 Hysteresis Dynamometer Setup.....	19
Figure 3-9 Hysteresis Setup Menu	19
Figure 3-10 Hysteresis Dynamometer with Torque Transducer Setup.....	20
Figure 3-11 Torque Transducer Setup Menu.....	21
Figure 3-12 Aux Setup Menu - Display On.....	21
Figure 3-13 TSC1 with TM2XX Output Menu.....	21
Figure 3-14 Hysteresis Dynamometer with Auxiliary Instrumentation Setup.....	22
Figure 3-15 TSC2 Aux Setup Menu	23
Figure 3-16 TSC1 with AUX Output Menu.....	23
Figure 3-17 Hysteresis Dynamometer with Eddy-Current or Powder Brake Setup.....	24
Figure 3-18 TSC2 Eddy-Current/Powder Brake Setup Menu	25
Figure 3-19 Nominal Speed Setup Menu.....	25
Figure 3-20 Eddy-Current or Powder Brake Dynamometer Setup	26
Figure 3-21 TSC1 Eddy-Current/Powder Brake Setup Menu	26
Figure 3-22 Eddy-Current or Powder Brake Dynamometer with Torque Transducer Setup	27
Figure 3-23 Eddy-Current or Powder Brake Dynamometer with Auxiliary Instrumentation Setup	28
Figure 3-24 Two Eddy-Current/Powder Brake Dynamometers (Independent Setup)	29
Figure 3-25 Tandem Configuration Menu.....	30
Figure 3-26 Two Eddy-Current/Powder Brake Dynamometers (Tandem Setup)	31
Figure 3-27 Eddy-Current Dynamometer with Powder Brake Dynamometer (Tandem Setup).....	33
Figure 3-28 TSC1 Eddy-Current Setup Menu	33
Figure 3-29 TSC2 Powder Brake Setup Menu.....	34
Figure 3-30 Maximum Speed Excited Menu	34
Figure 3-31 In-Line Torque Transducer Cross Loop Function	35
Figure 3-32 Brake Type Menu.....	35
Figure 3-33 Brake Type Menu (for WB).....	36
Figure 3-34 Encoder Menu	36
Figure 3-35 Torque/Speed DAC Setup Menu.....	37

4. DIGITAL FILTERS

Figure 4-1 Transposed Direct Form II Architecture.....	38
--	----

5. PID SETTINGS

Figure 5-1 System Block Diagram.....	41
Figure 5-2 Open Loop Control Menu.....	43
Figure 5-3 Initial P Setting for Torque Control at 25%	44

Figure 5-4 High Initial P Setting for Torque Control	44
Figure 5-5 Initial I Setting for Torque Control.....	45
Figure 5-6 Initial D Setting for Torque Control	45
Figure 5-7 Initial P Setting for Speed Control at 25%.....	46
Figure 5-8 Initial I Setting for Speed Control	47
Figure 5-9 Initial D Setting for Speed Control.....	47
Figure 5-10 Ramp Down Low I.....	48
Figure 5-11 Ramp Down High I.....	49
Figure 5-12 Ramp Down Dynamic I	49
6. ALARM SYSTEM	
Figure 6-1 Normal Condition “Energized Relay”	50
Figure 6-2 Alarm Condition “De-Energized Relay”	50
Figure 6-3 Typical Application.....	51
Figure 6-4 Alarm Enable/Disable Menu.....	51
Figure 6-5 Max Power Menu.....	52
Figure 6-6 Power Alarm Display	53
Figure 6-7 Speed Alarm Setup Menu.....	53
Figure 6-8 -OL- Speed Alarm Display	54
Figure 6-9 Over Speed Alarm Message Display.....	54
Figure 6-10 Torque Alarm Setup Menu	55
Figure 6-11 -OL- Torque Alarm Display.....	55
Figure 6-12 Over Torque Alarm Message Display.....	55
Figure 6-13 Air Flow Alarm Setup Display	56
Figure 6-14 Air Flow Alarm Message Display	56
Figure 6-15 Water Flow Alarm Setup Display	57
Figure 6-16 Water Flow Alarm Message Display	57
Figure 6-17 External Alarm Setup Display.....	58
Figure 6-18 External Alarm Message Display.....	58
Figure 6-19 Temperature Alarm Message Display.....	59
Figure 6-20 Electrical Alarm Message Display.....	60
7. MANUALLY CONTROLLED OPERATION	
Figure 7-1 Dynamometer Channel Menu.....	61
Figure 7-2 Power Units Menu	62
Figure 7-3 Torque Units Menu	62
Figure 7-4 Torque Control Menu.....	62
Figure 7-5 Max Speed Menu	63
8. COMPUTER CONTROLLED OPERATION	
Figure 8-1 GPIB Installation	65
Figure 8-2 Com Setup Menu Display.....	66
Figure 8-3 RS-232 Interface.....	66
Figure 8-4 Straight Through Pin-to-Pin Cable Connection.....	67
9. CALIBRATION	
Figure 9-1 Calibration Display Analog Inputs	77
Figure 9-2 TSC1 Input Connector.....	77
Figure 9-3 TSC2 Input Connector.....	78
Figure 9-4 Calibration Output DAC Display Menu.....	78
Figure 9-5 Supply 1 Connector	79
Figure 9-6 Supply 2 Connector	79
Figure 9-7 Calibration Accessory Torque DAC Display Menu.....	79
Figure 9-8 Accessory Torque-Speed Output.....	80
Figure 9-9 Calibration Accessory Speed DAC Display Menu	80

Preface

PURPOSE OF THIS MANUAL

This manual contains all the information required for the installation and general use of the Model DSP6001 Dynamometer Controller. To ensure proper use of the instrument, please read this manual thoroughly before operating it. Keep the manual in a safe place for quick reference whenever a question arises.

WHO SHOULD USE THIS MANUAL

This manual is intended for bench test operators who are going to use the Model DSP6001 Dynamometer Controller in conjunction with any Magtrol Hysteresis, Eddy-Current or Powder Brake Dynamometer, Magtrol In-Line Torque Transducer or auxiliary instrumentation.

MANUAL ORGANIZATION

This section gives an overview of the structure of the manual and the information contained within it. Some information has been deliberately repeated in different sections of the document to minimize cross-referencing and to facilitate understanding through reiteration.

The structure of the manual is as follows:

- Chapter 1: INTRODUCTION - Contains the technical data sheet for the DSP6001 Dynamometer Controller, which describes the unit and provides its technical characteristics.
- Chapter 2: CONTROLS - Description of the elements located on the front and rear panels of the unit.
- Chapter 3: INSTALLATION/CONFIGURATION - Provides setup options available with the DSP6001 Dynamometer Controller. Illustrates and outlines the hardware connection setup and software configurations for each option.
- Chapter 4: DIGITAL FILTERS - Contains theory and setup information pertaining to Digital Filters.
- Chapter 5: PID SETTINGS - Describes the Proportional Integral Derivative (PID) Loop and provides information on theory, setup and use.
- Chapter 6: ALARM SYSTEM - Describes the new built-in alarm feature providing the user with information on how each different alarm operates along with instructions for setup and use.
- Chapter 7: MANUALLY CONTROLLED OPERATION - How to run a test when the DSP6001 is used as a stand-alone unit. Includes information on setting power and torque units, torque and speed control and open loop control.
- Chapter 8: COMPUTER CONTROLLED OPERATION - How to run a test when the DSP6001 is used with a PC. Includes information on GPIB Interface, RS-232 Interface, data format, programming and command set.
- Chapter 9: CALIBRATION - Provides recommended calibration schedules along with step-by-step instructions for the calibration procedure.

- Chapter 10: TROUBLESHOOTING - Solutions to common problems encountered during setup and testing.
- Appendix A: LABVIEW™ PROGRAMMING EXAMPLES - Magtrol’s comprehensive motor-test software programs, made specifically to compliment the DSP6001 Dynamometer Controller.
- Appendix B: INERTIA CORRECTION - Describes the inertial effect on motor test data providing solutions for correction.
- Appendix C: FRONT PANEL/DISPLAY MENU FLOW CHARTS - A visual display of various setup procedures.
- Appendix D: REMOTE CONFIGURATION FLOW CHARTS - A visual display of the command set used when programming the DSP6001.
- Appendix E: SCHEMATICS - For Encoder/Switch Board, Power Supply, DSP & Memory and Analog I/O.
- Appendix F: ADDITIONAL SCALE FACTOR TABLE - Provides additional scale factor values based on test instrument selection.

CONVENTIONS USED IN THIS MANUAL

The following symbols and type styles may be used in this manual to highlight certain parts of the text:



Note: This is intended to draw the operator’s attention to complementary information or advice relating to the subject being treated. It introduces information enabling the correct and optimal functioning of the product to be obtained.



CAUTION : THIS IS USED TO DRAW THE OPERATOR'S ATTENTION TO INFORMATION, DIRECTIVES, PROCEDURES, ETC. WHICH, IF IGNORED, MAY RESULT IN DAMAGE BEING CAUSED TO THE MATERIAL BEING USED. THE ASSOCIATED TEXT DESCRIBES THE NECESSARY PRECAUTIONS TO TAKE AND THE CONSEQUENCES THAT MAY ARISE IF THE PRECAUTIONS ARE IGNORED.



WARNING! THIS INTRODUCES DIRECTIVES, PROCEDURES, PRECAUTIONARY MEASURES, ETC. WHICH MUST BE EXECUTED OR FOLLOWED WITH THE UTMOST CARE AND ATTENTION, OTHERWISE THE PERSONAL SAFETY OF THE OPERATOR OR THIRD PARTIES MAY BE PUT AT RISK. THE READER MUST ABSOLUTELY TAKE NOTE OF THE ACCOMPANYING TEXT, AND ACT UPON IT, BEFORE PROCEEDING FURTHER.

1. Introduction

1.1 UNPACKING YOUR DSP6001

Your DSP6001 was packaged carefully for shipping. Please notify your carrier and Magtrol Customer Service if you believe your unit was damaged in shipping.

1. Save all shipping cartons and packaging material until you inspect the DSP6001.
2. Inspect the DSP6001 for any evidence of damage in shipping.
3. Make sure the carton contains the following:

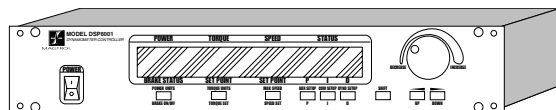

DSP6001 Dynamometer Controller

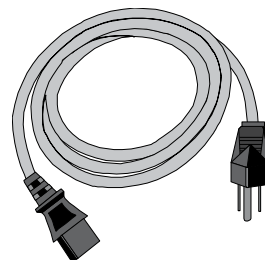

Line cord

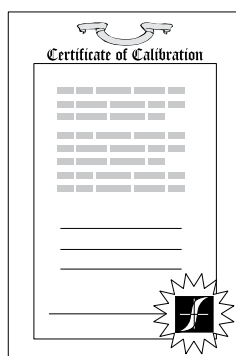

Calibration Certificate

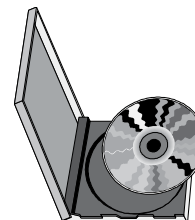

Magtrol User Manual CD-Rom

1.2 NEW FEATURES OF THE DSP6001

Magtrol's new Model DSP6001 Dynamometer Controller is an upgraded version of the DSP6000, providing superior motor testing capabilities by using state-of-the-art digital signal processing technology. Designed for use with any Magtrol Hysteresis, Eddy-Current or Powder Brake Dynamometer, Magtrol In-Line Torque Transducer or auxiliary instrumentation, the DSP6001 both controls the dynamometer and provides digital readouts on the front panel. The features that make the DSP6001 unique include:

- Two Channels - Enables unit to support a combination of up to two testing instruments with independent or tandem configurations.
- Built-In Alarm System - To caution the user when problems occur, there are automatic electrical and temperature alarms programmed into the unit. Also inherent to the unit are optional power, speed, torque, air flow, water flow and external input alarms that become active when enabled by the user.
- Torque/Speed Analog Outputs - Able to interface with a data acquisition system or strip chart recorder.
- Digital Filter - Removes undesired noise from torque signals.
- Cross Loop Function - Allows closed loop control of a brake via the torque transducer.
- Saving - Allows user to save programmed values within their configurations.

1.3 DATA SHEET

DSP6001 High-Speed Programmable Dynamometer Controller

FEATURES

- **Two Channels:** Enable the unit to support up to two testing instruments with independent or tandem configurations.
- **Built-in Alarm System:** For power, speed, torque, temperature, air flow, water flow, electrical overload and external inputs
- **Torque/Speed Analog Outputs:** For interface with a data acquisition system or strip chart recorder
- **Interfaces:** RS-232 and IEEE-488
- **High Speed Data Acquisition:** 120 torque and speed points per second via IEEE bus (approx. 60/sec. via RS-232)
- **High Quality, Easy-to-Read Vacuum Fluorescent Readout:** Displays torque, speed, power, auxiliary and PID (proportional gain, integral and derivative) values
- **Fast Full-Curve Data Acquisition:** Free-run to locked rotor in seconds
- **Speed & Torque Operating Modes:** Provide independent PID settings for improved Dynamometer control
- **Built-in Current-Regulated Supply:** For use with Hysteresis Dynamometer only
- **Adjustable Torque Units:** English, Metric and SI are standard
- **Dynamometer Overload Protection**
- **Digital Filter:** Removes undesired noise from torque signals
- **Cross Loop Function:** Allows closed loop control of brake via torque transducer
- **Programmable Digital PID Values:** Controlled and stored via M-Test Software or controlled manually
- **Saving:** Saves programmed values within configuration
- **Auxiliary ± 10 VDC Analog Input:** For additional transducer
- **Single or Multi-point Torque and Speed Stabilized Testing:** Via M-TEST 5.0 Software
- **Closed Box Calibration**
- **Rack Mounting:** 19" (482.6 mm) with handles

DESCRIPTION

Magtrol's Model DSP6001 High Speed Programmable Dynamometer Controller employs state-of-the-art Digital Signal Processing Technology to provide superior motor testing

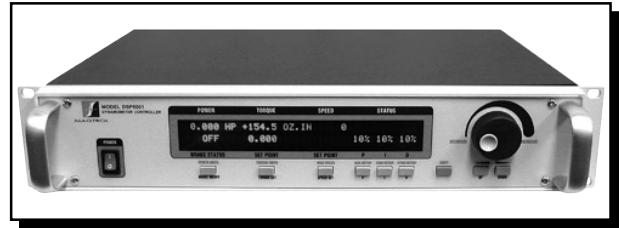

capabilities. Designed for use with any Magtrol Hysteresis, Eddy-Current or Powder Dynamometer, Magtrol In-Line Torque Transducer or auxiliary instrumentation, the DSP6001 can provide complete PC control via the IEEE-488 or RS-232 interface. With 120 readings per second, the DSP6001 is ideally suited for both the test lab and the production line.

APPLICATIONS

In the laboratory, the DSP6001's high sample rate provides superior resolution for data acquisition and curve plotting. This allows for capturing more usable motor test data during switching, breakdown and other transitional areas of the motor test curve. For production and incoming inspection, the DSP6001 displays torque, speed and power at all times, allowing the Controller to be used as a manual stand alone unit or as part of a complete PC system.

MOTOR TESTING SOFTWARE

Magtrol's M-TEST 5.0 Software (*sold separately*) is a state-of-the-art motor testing program for Windows®-based data acquisition. Used with the Magtrol DSP6001 Controller, Magtrol M-TEST 5.0 Software provides the control of any Magtrol Dynamometer and runs test sequences in a manner best suited to the overall accuracy and efficiency of the Magtrol Motor Test System. The data that is generated by Magtrol's Motor Testing Software can be stored, displayed and printed in tabular or graphic formats, and can be easily imported into a spreadsheet.

Written in LabVIEW™, M-TEST 5.0 has the flexibility to test a majority of motor types in a variety of ways. Because of LabVIEW's versatility, obtaining data from other sources (e.g. thermocouples), controlling motor power and providing audio/visual indicators is relatively easy.

Magtrol's M-TEST 5.0 Software is ideal for simulating loads, cycling the unit under test and motor ramping. Because it is easy to gather data and duplicate tests, the software is ideal for use in engineering labs, production testing and incoming/outgoing inspection.

Specifications

DSP6001

MEASUREMENT CHARACTERISTICS	
Maximum Torque	10,000 units, ±5 V TSC1, ±10 V TSC2
Maximum Speed	99,999 rpm
Accuracy	Speed: 0.01% of reading from 10 rpm to 100,000 rpm TSC1: 0.02% of range (±1 mV) TSC2: 0.02% of range (±2 mV)
ELECTRICAL CHARACTERISTICS	
Fuses (5 × 20 mm)	Brake: UL/CSA 1.25 A 250 V SB IEC 1.00 A 250 V T
	Power (120 V): UL/CSA 800 mA 250 V SB Power (240 V): IEC 315 mA 250 V T
Power Requirements	75 VA
Voltage Requirements	120/240 V 60/50 Hz
Max. Compliance Voltage	45 VDC, Brake Output
INPUTS AND OUTPUTS	
Maximum Torque Input	TSC1: ±5 VDC TSC2: ±10 VDC
Accessory Torque/Speed Output	Torque: ±10 VDC Speed: ±10 VDC
Ctrl Out	0–3 VDC
ENVIRONMENT	
Operating Temperature	5 °C to 40 °C
Relative Humidity	< 80%
Temperature Coefficient	0.004% of range/°C of 5 VDC for both channels

DIMENSIONS		
Width	19.0 in	483 mm
Height	3.5 in	89 mm
Depth with handles	12.4 in	315 mm
	13.8 in	351 mm
Weight	16.73 lb	7.58 kg

FRONT PANEL

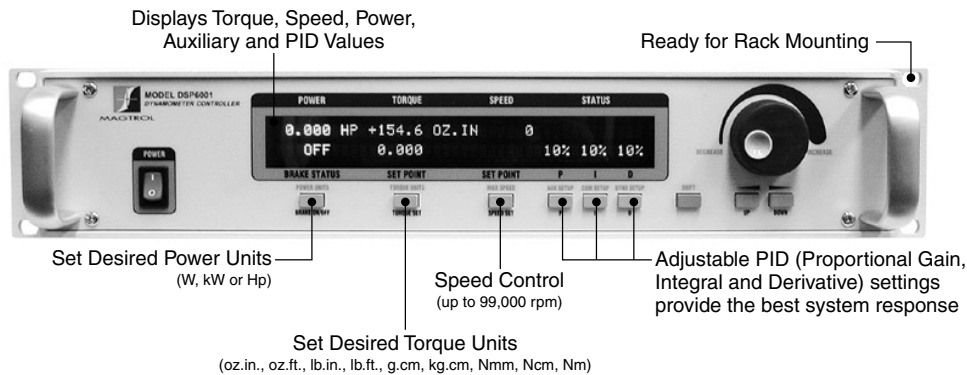

REAR PANEL

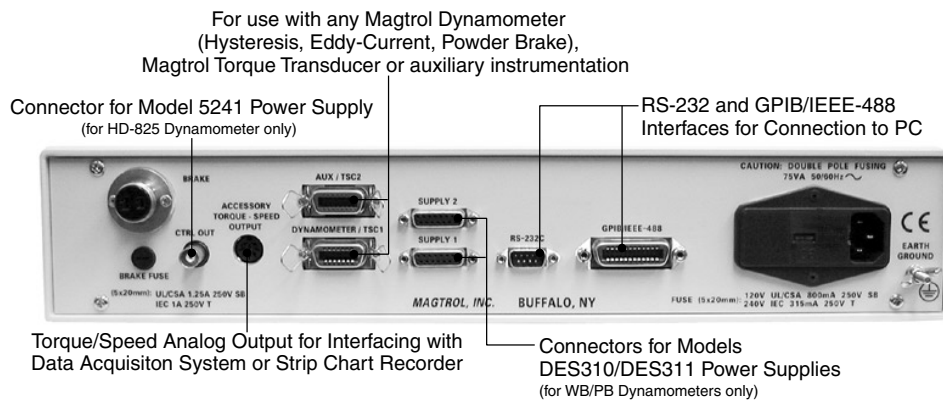

System Configurations

DSP6001

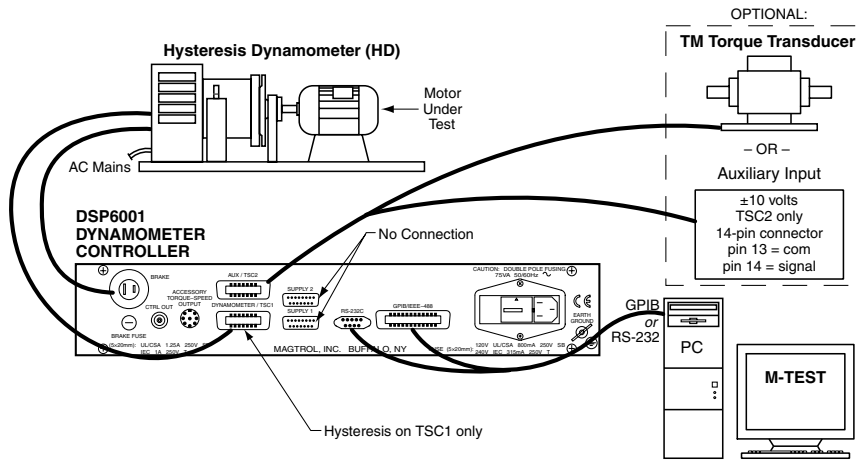

DSP6001 Connected to Hysteresis Dynamometer with Optional Auxiliary Input or In-Line Torque Transducer

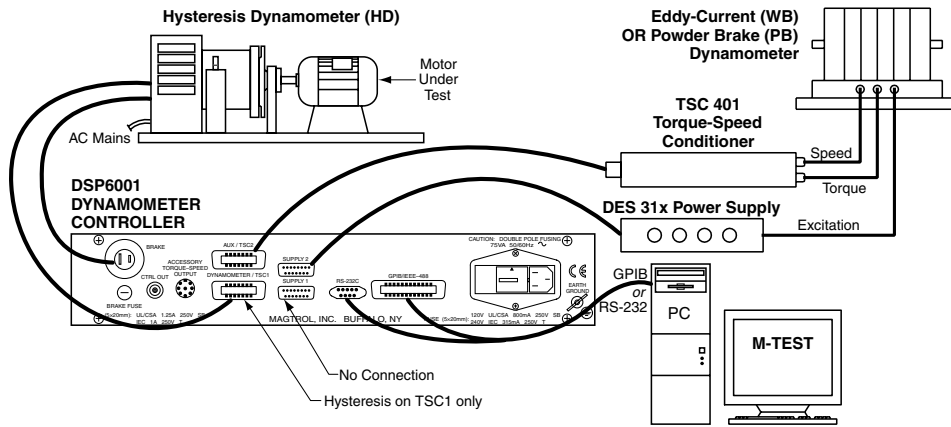

DSP6001 Connected to Hysteresis Dynamometer and Eddy-Current or Powder Brake Dynamometer

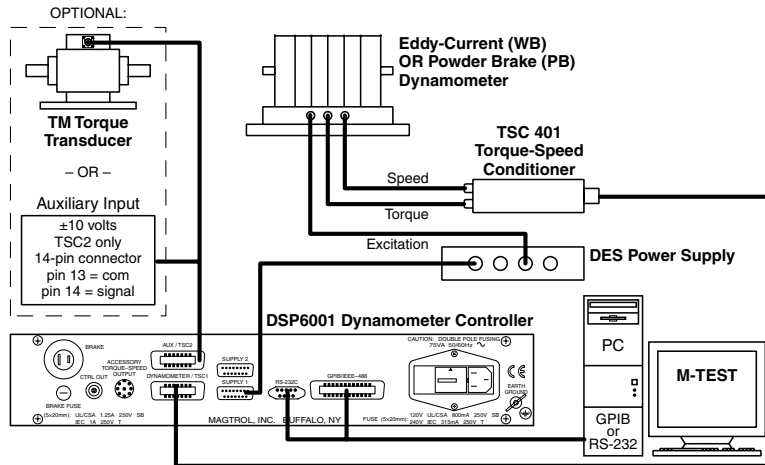

DSP6001 Connected to Eddy-Current or Powder Brake Dynamometer (WB/PB) with Optional Auxiliary Input or In-Line Torque Transducer

System Configurations

DSP6001

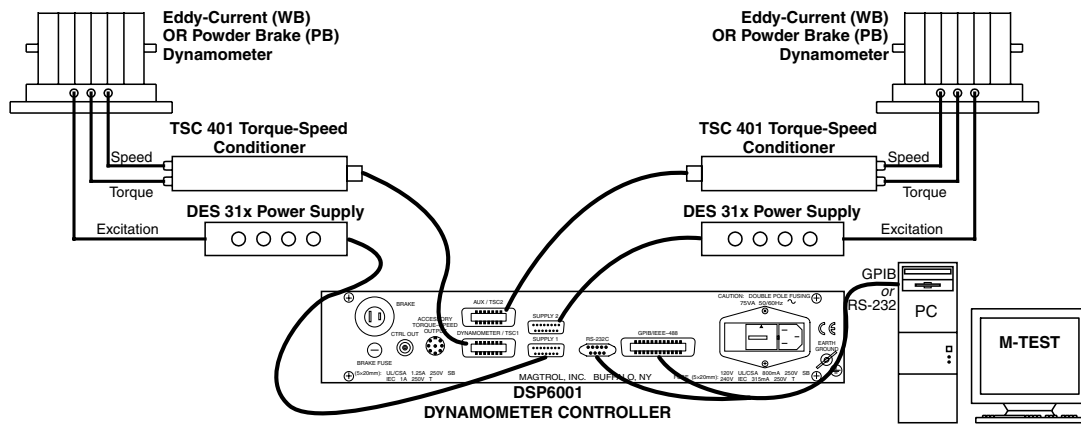

DSP6001 Connected to 2 Eddy-Current or Powder Brake Dynamometers (Independent Setup)

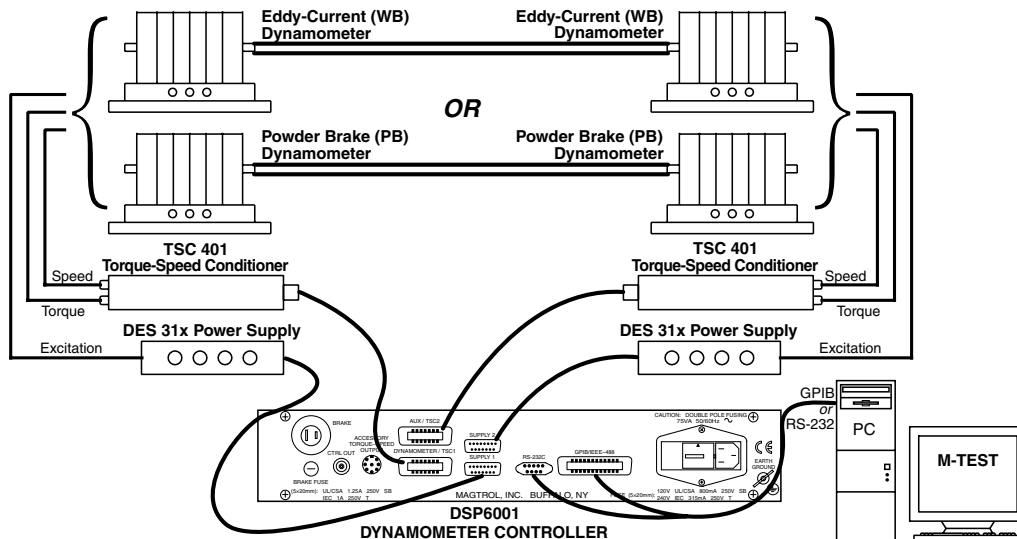

DSP6001 Connected to 2 Eddy-Current or 2 Powder Brake Dynamometers (Tandem Setup)

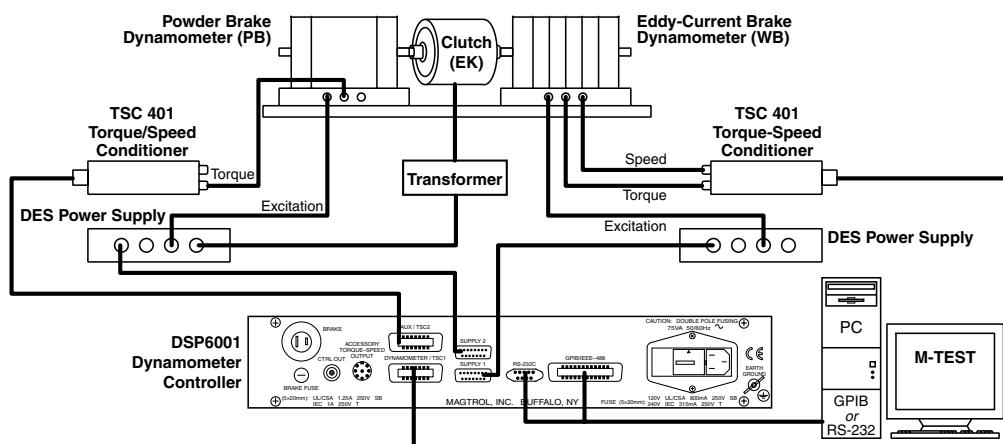

DSP6001 Connected to Eddy-Current and Powder Brake Dynamometer (Tandem Setup)

System Configurations

DSP6001

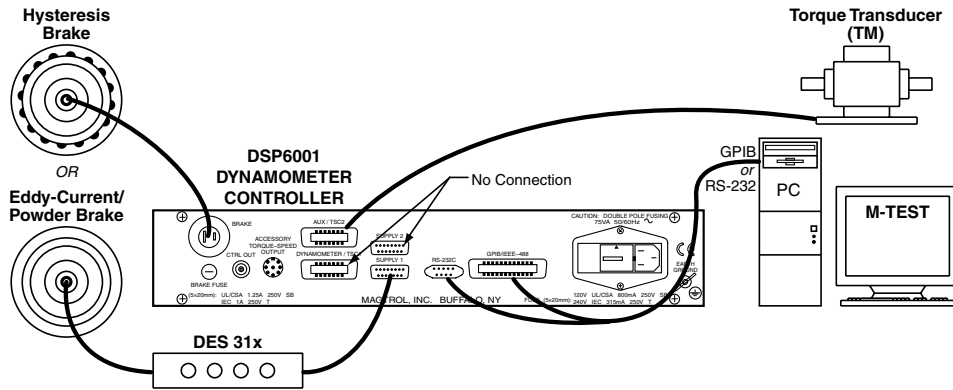

In-Line Torque Transducer Cross Loop Function

CUSTOM MOTOR TEST SYSTEM

The DSP6001 can be incorporated into a Customized Motor Test System. These PC based, turn-key systems are custom designed and built to meet specific user requirements.

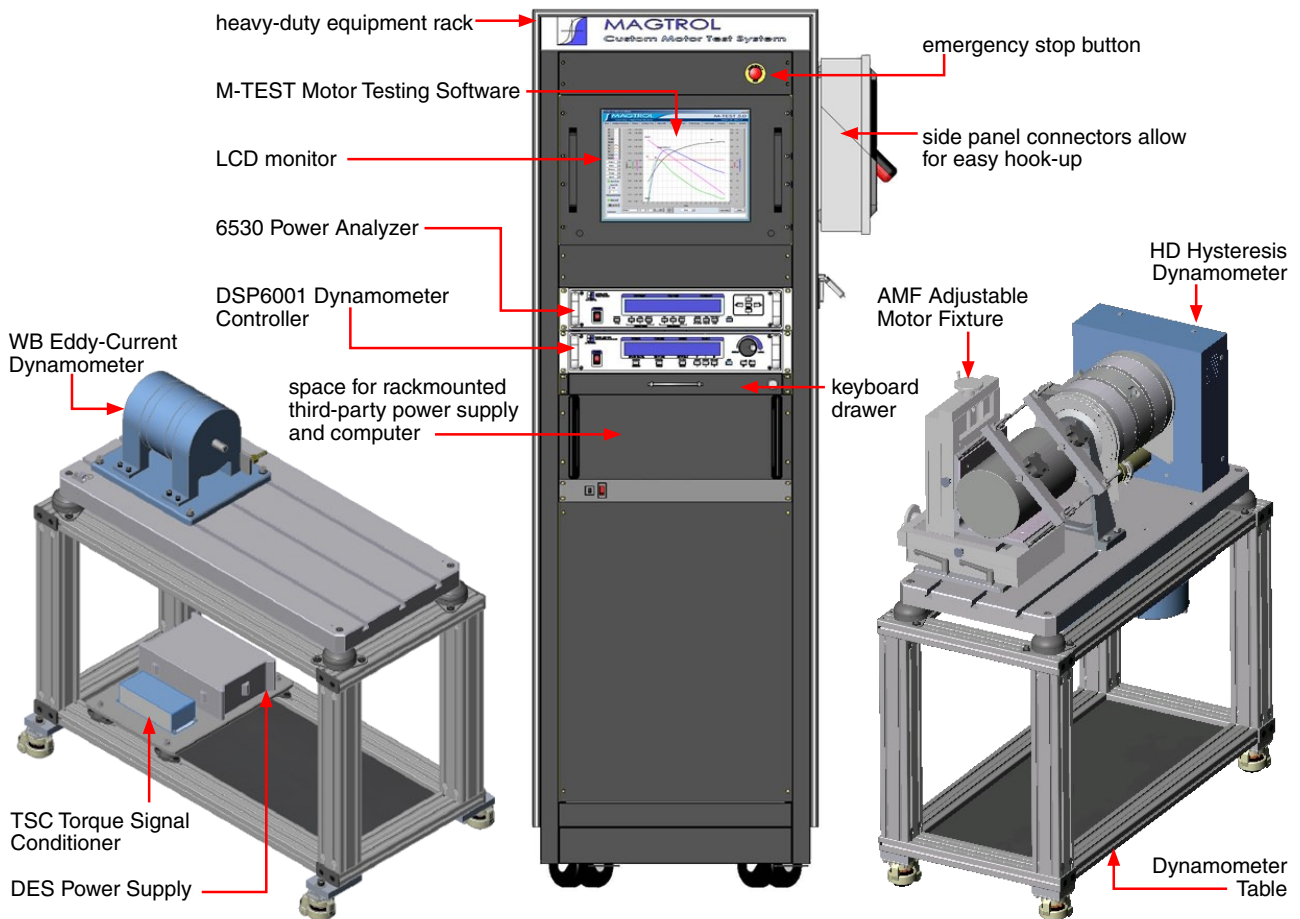

Ordering Information

DSP6001

ORDERING INFORMATION

DSP6001	High-Speed Programmable Dynamometer Controller	120 VAC
DSP6001A	High-Speed Programmable Dynamometer Controller	240 VAC

SYSTEM OPTIONS AND ACCESSORIES

CATEGORY	DESCRIPTION	MODEL / PART #
TESTING DEVICES	Hysteresis Dynamometers	HD series
	Eddy-Current Dynamometers	WB series
	Powder Brake Dynamometers	PB series
	In-Line Torque Transducers	TM/TMHS/TMB series
POWER ANALYZERS	High-Speed Single-Phase Power Analyzer	6510 e
	High-Speed Three-Phase Power Analyzer	6530
SOFTWARE	M-TEST 5.0 Motor Testing Software	SW-M-TEST5.0-WE
	Temperature Testing Hardware	HW-TTEST
POWER SUPPLIES	Closed-Loop Speed Control/Power Supply	6100
	Power Supply	5200
	Current-Regulated Power Supply	5210
	Power Amplifier <i>(required for HD-825 Dynamometer only)</i>	5241
	Power Supply for WB & PB Dynamometers series 2.7 and 43	DES 310
	Power Supply for WB & PB Dynamometer series 65, 115 and 15	DES 311
MISC.	Torque/Speed Conditioner <i>(required for connecting WB/PB Series Dynamometers to DSP6001)</i>	TSC 401
CARDS & CABLES	GPIB Interface Card (PCI)	73-M023
	GPIB Cable, 1 meter	88M047
	GPIB Cable, 2 meters	88M048
	Torque Transducer Connector Cable	EB 113/01

Due to the continual development of our products, we reserve the right to modify specifications without forewarning.

2. Controls

2.1 FRONT PANEL

The front panel provides a power switch, nine control buttons, a Decrease/Increase Dial, and Vacuum Fluorescent Display (VFD).

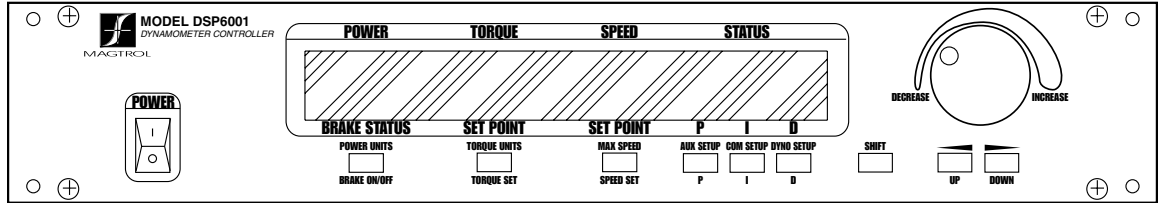

Figure 2-1 Front Panel

2.2 FRONT PANEL CONTROLS AND BUTTONS

The front panel controls and buttons, from left to right, are:

- Power switch
- Six double-function control button:

Primary Function	Secondary Function
BRAKE ON/OFF	POWER UNITS
TORQUE SET	TORQUE UNITS
SPEED SET	MAX SPEED
P	AUX SETUP
I	COM SETUP
D	DYNO SETUP

- Three single-function control buttons:
 - SHIFT (enables saving function and secondary functions printed in blue above control buttons)
 - UP - Left arrow ◀ (moves cursor to the left)
 - DOWN - Right arrow ▶ (moves cursor to the right)
- Decrease/Increase Dial (decreases or increases the selected parameter)

2.2.1 ENABLING SECONDARY FUNCTIONS

To enable the secondary function of the double-function control buttons:

1. Press the blue SHIFT button and release it. The word “SHIFT” appears in the display:

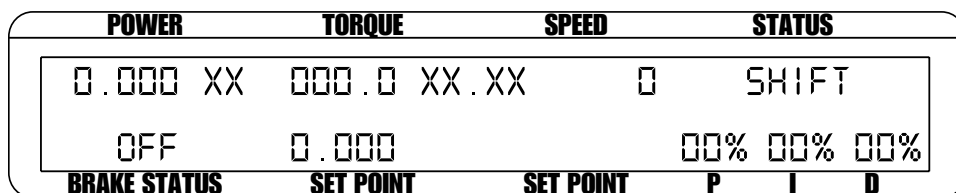

Figure 2-2 Secondary Function Menu

2. Press any control button to enable the function shown in blue letters above the button.
3. Press the SHIFT button again to exit the secondary function and return to main menu.



Note: If the brake status is ON, the SHIFT button will be ignored.

2.2.2 ENABLING SAVING FUNCTION

To save all current programmed settings:

1. Press the SHIFT button two times. The word “SAVING” will appear in the display, as shown in *Figure 2–3 Saving Function Menu*.

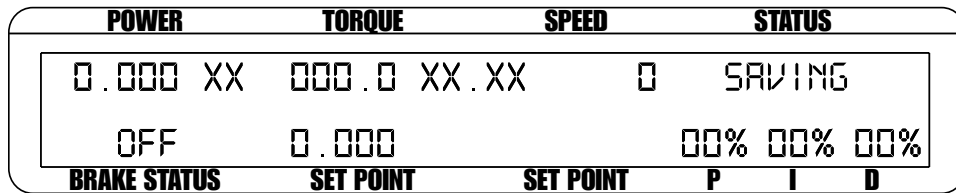

Figure 2–3 Saving Function Menu

2. After a few seconds, the menu will automatically return to the main menu display and all configurations of the unit will be saved into a non-volatile memory.

2.2.3 HOW TO USE FRONT PANEL CONTROLS AND BUTTONS

2.2.3.1 Controls/Single-Function Buttons

Button	To Use	Function
POWER	Press I to turn power ON Press O to turn power OFF.	Turns power ON or OFF.
SHIFT	Press this button and release; then press desired control button.	Enables the function written in blue above control button.
	Press this button two times and release.	Saves current configuration of unit to non-volatile memory.
UP/LEFT ◀	Press.	Increases magnitude of change when adjusting a numerical value (speed, torque or max. speed).
DOWN/RIGHT ▶	Press.	Decreases magnitude of change when adjusting a numerical value (speed, torque or max. speed).
DECREASE / INCREASE DIAL	Turn clockwise or counterclockwise.	Increases or decreases the parameter selected.

2.2.3.2 Double-Function Buttons

Button	To Use	Function
POWER UNITS	Press SHIFT and release; then press this button.	Sets desired unit of power. Press UP ◀ or DOWN ▶ button to see options. Press SHIFT to enable option.
BRAKE ON/OFF	Press this button.	Turns brake ON or OFF.
TORQUE UNITS	Press SHIFT and release; then press this button.	Sets desired unit of measure. Press UP ◀ or DOWN ▶ button to see options. Press SHIFT to enable option.
TORQUE SET	Press this button.	Enables adjustment of set point for torque loading.
	Press and hold this button until second beep.	Enables Open Loop mode (if brake is off).
MAX SPEED	Press SHIFT and release; then press this button.	Sets the speed range of the Controller.
SPEED SET	Press this button.	Enables adjustment of set point for speed loading.
AUX SETUP	Press SHIFT and release; then press this button.	Turns auxiliary/torque transducer display ON or OFF. Enables adjustment of scale factors for torque and speed DAC'S.
P	Press this button.	Enables adjustment of proportional term.
COM SETUP	Press SHIFT and release; then press this button.	Adjusts GPIB primary address and RS-232 baud rate. Also adjusts display contrast.
I	Press this button.	Enables adjustment of integral term.
DYNO SETUP	Press SHIFT and release; then press this button.	Provides options to set maximum power, dynamometer settings (input units, maximum torque and scale factor), speed encoders and alarms.
D	Press this button.	Enables adjustment of derivative term.

2.3 VACUUM FLUORESCENT DISPLAY (VFD)

The VFD provides information about the control functions, the motor under test, and an auxiliary input device or In-Line Torque Transducer (if connected). The displays, from left to right, are:

Top Row	Bottom Row
POWER	BRAKE STATUS (ON or OFF)
TORQUE	SET POINT (TORQUE)
SPEED	SET POINT (SPEED)
AUX INPUT, TM2XX or STATUS DISPLAY	P
	I
	D

2.3.1 CONTRAST SETTINGS

The DSP6001 is shipped with the Contrast Setting at zero (lowest) in order to prolong display life. If it is necessary to increase the Contrast for improved readability, execute the following steps:

1. Press SHIFT.
2. Press COM SETUP button.
3. Select CONTRAST until desired brightness is reached.
4. Press SHIFT to return to main menu.



Note: Make sure the lowest possible setting is used to achieve desired result. Using a setting higher than necessary may cause display segments to burn-in over a period of time, resulting in uneven illumination from segment to segment.

2.3.2 SCREEN SAVER

In order to help eliminate the possibility of display damage, a Screen Saver has been programmed into the DSP6001. If the display has been turned on for more than 5 minutes without any activity, a Screen Saver with moving arrows will appear.

The display can be reactivated by any one of the following actions:

1. Touch any button on the Front Display Panel.
2. Send a command through the GPIB interface.
3. RPM activity in the motor under test.



Note: This function was removed after code revision 7.2.

2.3.3 STATUS DISPLAY MESSAGES

Message	Meaning
SHIFT	Shift button was pressed.
AUX	Auxiliary unit is attached and enabled.
Nm	Torque Transducer attached and enabled.
MAX SPEED	Maximum motor RPM.
I/O ERROR	Incorrect command was sent from computer.
UNITS	Torque unit of measurement.
REMOTE	Remote control via PC enabled.
RAMP DOWN	Decrease motor speed by increasing load on motor.
RAMP UP	Increase motor speed by decreasing load on motor.
SAVING	Saves current configuration of unit to non-volatile memory.

2.4 REAR PANEL

The rear panel provides connectors and receptacles for connecting to appropriate equipment.

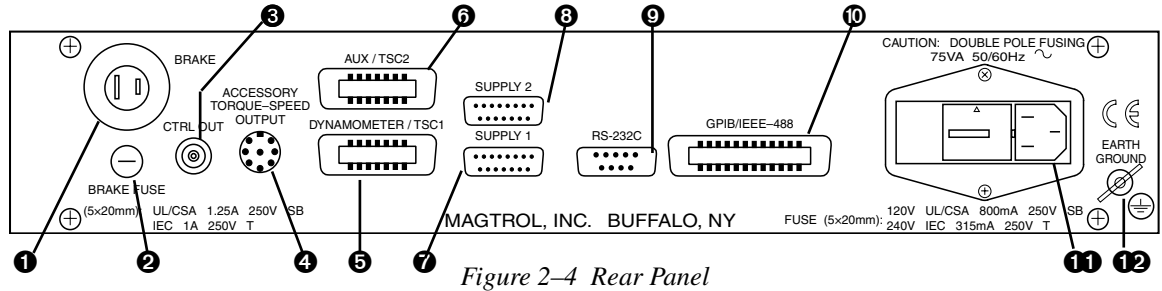

Figure 2-4 Rear Panel

2.5 REAR PANEL INPUTS AND OUTPUTS

- 1 BRAKE Connect dynamometer brake cable here.



Figure 2-5 Dynamometer Brake Input

- 2 BRAKE FUSE Contains brake fuse (5 x 20 mm)
(UL/CSA 1.25A 250V SB)
(IEC 1A 250V T)
- 3 CTRL OUT Connect to Model 5241 Power Amplifier when using HD-825 Dynamometer.

- 4 ACCESSORY TORQUE/SPEED OUTPUT Connect accessory output cable here (optional).

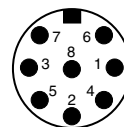

- 1. ANALOG TORQUE
- 2. ANALOG SPEED
- 3. ANALOG GROUND
- 4. ALARM RELAY (NORMALLY OPEN)
- 5. ALARM RELAY (NORMALLY CLOSED)
- 6. ALARM RELAY (COMMON)
- 7. EXTERNAL ALARM INPUT
- 8. +5.0 VDC COM

Figure 2-6 Accessory Torque-Speed Output

- 5** DYNAMOMETER/ TSC1 Connect dynamometer signal cable here.

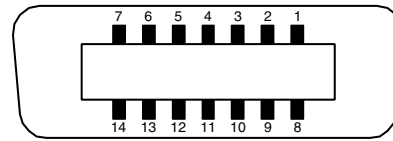

- | | |
|----------------|-------------------|
| 1. FLOW/CLUTCH | 8. +5.0 VDC COM |
| 2. TACH. B | 9. D.P. A |
| 3. +24 VDC | 10. TACH. A |
| 4. +24 VDC COM | 11. INDEX |
| 5. -24 VDC COM | 12. D.P. B |
| 6. -24 VDC | 13. TORQUE COMMON |
| 7. +5.0 VDC | 14. TORQUE SIGNAL |

Figure 2–7 Dynamometer/TSC1 Connector

- 6** AUX/TSC2 Connect signal cables for the dynamometer, TM2XX or auxiliary instrument here.

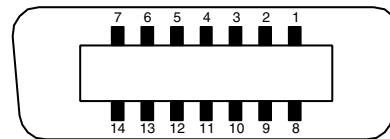

- | | |
|----------------|-------------------|
| 1. SPARE | 8. +5.0 VDC COM |
| 2. N/C | 9. ROT_SENS |
| 3. +24 VDC | 10. TACH. C |
| 4. +24 VDC COM | 11. N/C |
| 5. -24 VDC COM | 12. BITE |
| 6. -24 VDC | 13. TORQUE COMMON |
| 7. +5.0 VDC | 14. TORQUE SIGNAL |

Figure 2–8 AUX/TSC2 Connector

- 7** SUPPLY 1 Connect WB/PB DES supply for TSC1.

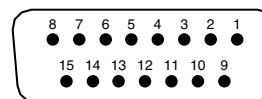

1. SHIELD (EARTH)
2. ELECTRICAL ALARM CHANNEL 1
3. N/C
4. PRIMARY SUPPLY CONTR. CHANNEL 1
5. SUPPLY +24 VDC
6. +5.0 VDC COM
7. CURRENT SET POINT (SIGNAL)
8. W FLOW_1
9. SHIELD (EARTH)
10. TEMPERATURE ALARM CHANNEL 1
11. STAND-BY CHANNEL 1
12. SUPPLY +24 VDC
13. +5.0 VDC COM
14. CURRENT SET POINT (ANALOG 0V)
15. N/C

Figure 2–9 Supply 1 Connector

8 SUPPLY 2 Connect WB/PB DES supply for TSC2.

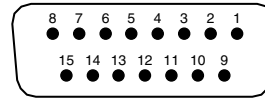

- 1. SHIELD (EARTH)
- 2. ELECTRICAL ALARM CHANNEL 2
- 3. CLUTCH
- 4. PRIMARY SUPPLY CONTR. CHANNEL 2
- 5. SUPPLY +24 VDC
- 6. +5.0 VDC COM
- 7. CURRENT SET POINT (SIGNAL)
- 8. W FLOW_2
- 9. SHIELD (EARTH)
- 10. TEMPERATURE ALARM CHANNEL 2
- 11. STAND-BY CHANNEL 2
- 12. SUPPLY +24 VDC
- 13. +5.0 VDC COM
- 14. CURRENT SET POINT (ANALOG 0V)
- 15. N/C

Figure 2–10 Supply 2 Connector

9 RS-232C Use this socket for RS-232 connector cable

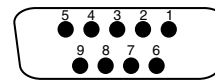

- 1.
- 2. TX
- 3. RX
- 4.
- 5. GND
- 6.
- 7.
- 8.
- 9. N/C

Figure 2–11 RS-232C Interface

10 GPIB/IEEE-488 Use this socket for GPIB cable (meets IEEE-488 specifications).

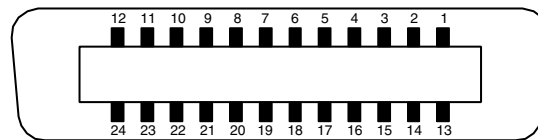

- | | |
|------------|-------------------|
| 1. D1 | 13. D5 |
| 2. D2 | 14. D6 |
| 3. D3 | 15. D7 |
| 4. D4 | 16. D8 |
| 5. E01 | 17. REN |
| 6. DAV | 18. DAV-COM |
| 7. NRFD | 19. NRFD-COM |
| 8. NDAC | 20. NDAC-COM |
| 9. IFC | 21. IFC-COM |
| 10. SRQ | 22. SRQ-COM |
| 11. ATN | 23. ATN-COM |
| 12. SHIELD | 24. SIGNAL GROUND |

Figure 2–12 GPIB/IEEE-488 Interface

11 POWER Attach power cord here.

12 EARTH GROUND Attach earth ground here.

3. Installation/Configuration



Note: Before installing the DSP6001, you should become familiar with the front and rear panels, as outlined in *Chapter 2—Controls*.

3.1 POWERING UP THE DSP6001



WARNING! TO REDUCE THE RISK OF ELECTRIC SHOCK, MAKE SURE THE DSP6001 IS EARTH GROUNDED BEFORE STARTING!

3.1.1 SETTING UNIT FOR LINE VOLTAGE

The DSP6001 will operate with either of the following power sources:

- 120 V 50/60 Hz
 - 240 V 50/60 Hz
1. Find the line cord receptacle on rear panel. The line cord is a detachable NEMA Standard 3 wire.
 2. Make sure the selector matches the power source (numbers should match the line voltage).

If not:

- Locate the power entry module.
- Remove the line cord.
- Insert a screwdriver into the slot and open the cover.
- Slide the voltage selector so the desired line voltage appears in the window.
- Install the appropriate fuses for that voltage.

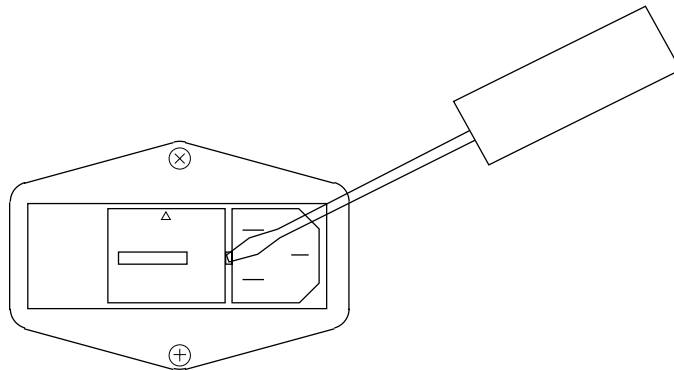

Figure 3–1 Cover for Voltage Selector, Fuses

3.1.2 SELF-TEST

After turning the power on to the DSP6001, the display panel will show all segments of the VFD (series of rectangles), indicating that the DSP6001 is downloading the program.

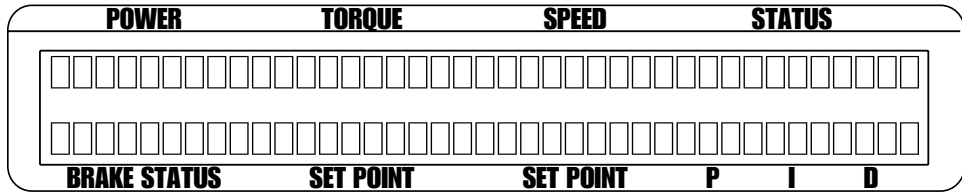

Figure 3-2 Program Download Display

When the program download is complete, the message “MAGTROL MODEL DSP6001 Revision X.X” appears.

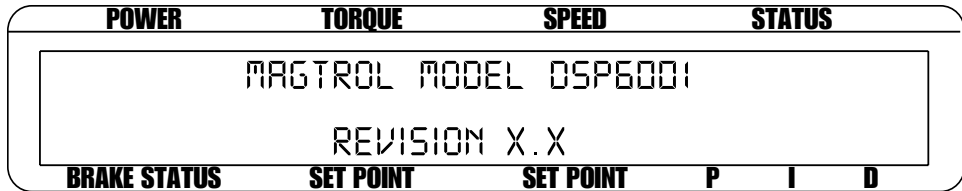

Figure 3-3 Revision Display

If the alarms are disabled, the following display message will appear at this time.

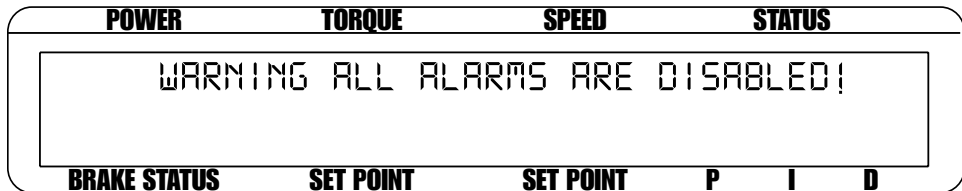

Figure 3-4 Alarm Warning Display

To activate the alarms, refer to *Section 6.1.2.1 – How to Enable/Disable Alarms*.

3.1.3 MAIN MENU

When the DSP6001 is completely powered up and ready for use, the main menu will appear on the display.

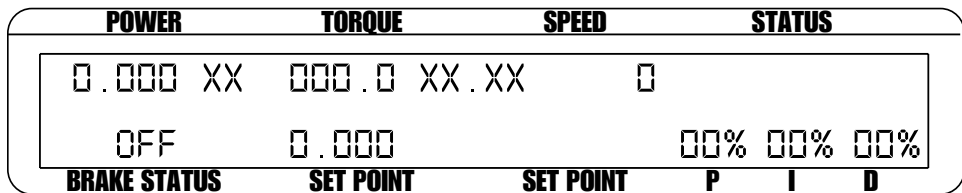

Figure 3-5 Main Menu

3.2 TESTING INSTRUMENTATION SETUP

The DSP6001 has the ability to support a combination of up to two testing instruments with independent or tandem configurations. Typically used combinations include:

TSC1	TSC2
HD	---
HD	TM2XX
HD	AUX
HD	WB or PB
WB or PB	---
WB or PB	TM2XX
WB or PB	AUX
WB or PB	WB or PB
BRAKE	TM2XX

- HD = Hysteresis Dynamometer
- WB = Eddy-Current Dynamometer
- PB = Powder Brake Dynamometer
- TM2XX = In-Line Torque Transducer
- AUX = Auxiliary Instrumentation
- BRAKE = Hysteresis, Eddy-Current or Powder Brake
- = no connection



Notes:

1. Only one Hysteresis Dynamometer, In-Line Torque Transducer or Auxiliary Instrument can be attached to the unit at any one time.
2. In the TSC1 (WB/PB) and TSC2 (WB/PB) combination, the instruments can be configured independently or as a tandem unit.
3. When there is no connection on TSC1 and TM2XX is connected to TSC2, the TM2XX will control the outputs of TSC1.

The setup of your unit will depend on which option you choose. The following sections will illustrate and outline the hardware connection and software configurations needed to begin your testing, based on your selection. For additional reference, see *Appendix C: Front Panel/Display Menu Flow Charts*.

SETUP

3.2.1 DYNAMOMETER CONFIGURATION MENU

To reach the dynamometer configuration menu:

1. Turn on DSP6001 power. See *Section 3.1 – Powering Up the DSP6001*.
2. Press SHIFT. The word “SHIFT” will appear in the display.
3. Press the DYNO SETUP button. The display should appear as follows:

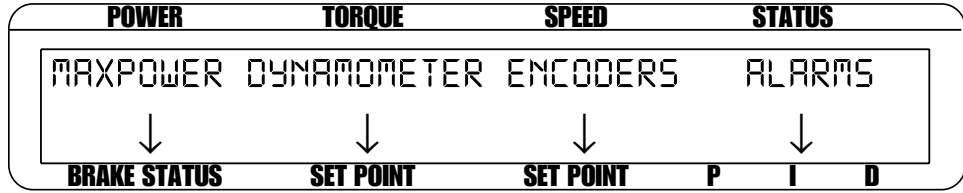

Figure 3-6 Dyno Setup Menu

4. Select DYNAMOMETER. The display should appear as follows:

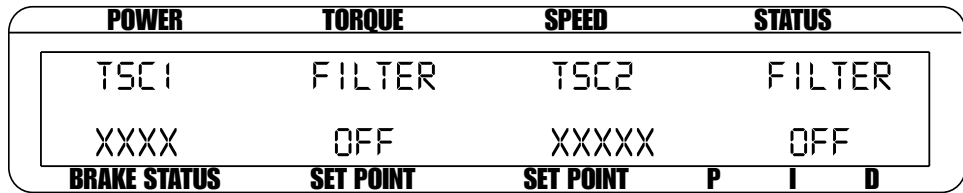

Figure 3-7 Dynamometer Configuration Menu

5. Pressing the POWER UNITS button allows selection of the preferred testing device (HD, WB, PB or BRAKE) for TSC1. Pressing the MAX SPEED button allows selection of the preferred testing device (AUX, WB, PB or TM2XX) for TSC2. Refer to the remainder of this chapter for more detailed instructions on setup and configuration of the different testing devices.



Note: For information on Filters, see *Chapter 4 – Digital Filters*.

SETUP

3.2.2 HYSTERESIS DYNAMOMETER SETUP

3.2.2.1 Hardware Connection

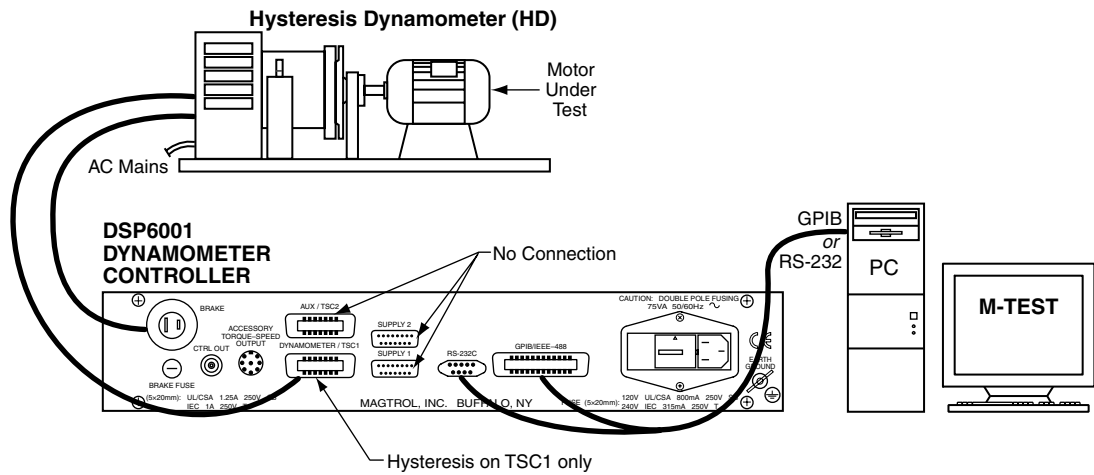

Figure 3–8 Hysteresis Dynamometer Setup

3.2.2.2 Software Configuration

1. Turn on the DSP6001 and proceed to the dynamometer configuration menu. See Section 3.2.1 – Dynamometer Configuration Menu.
2. Select TSC1 until HD is reached.
3. Select TSC2 until AUX is reached.
4. Press SHIFT. The display should appear as follows:

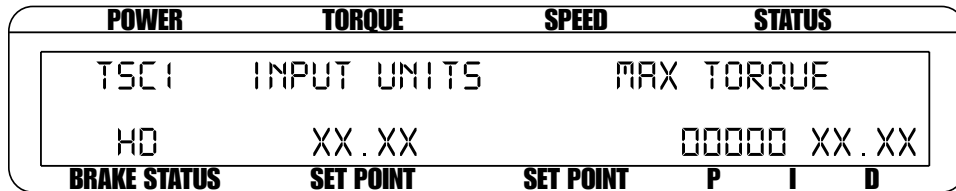

Figure 3–9 Hysteresis Setup Menu

5. Press the TORQUE UNITS button until the desired input unit for TSC1 is reached.
6. Press SHIFT 3 times to complete the initial setup and return to the main menu.

SETUP

3.2.3 HYSTERESIS DYNAMOMETER WITH TORQUE TRANSDUCER SETUP

3.2.3.1 Hardware Connection

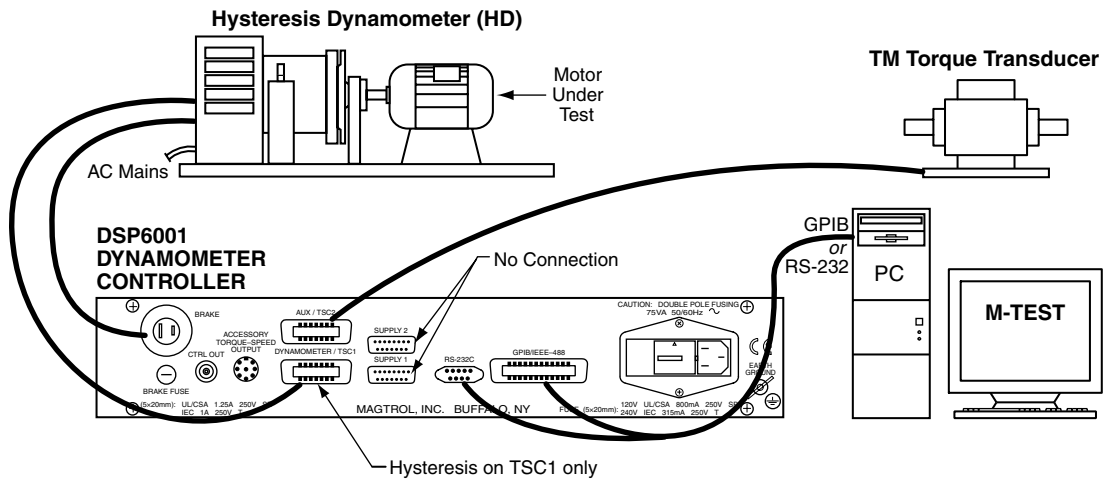

Figure 3–10 Hysteresis Dynamometer with Torque Transducer Setup

SETUP

3.2.3.2 Software Configuration

1. Turn on the DSP6001 and proceed to the dynamometer configuration menu. *See Section 3.2.1 – Dynamometer Configuration Menu.*
2. Select TSC1 until HD is reached.
3. Select TSC2 until TM2XX is reached.
4. Press SHIFT to get to the hysteresis setup menu. *See Figure 3–9 Hysteresis Setup Menu.*
5. Press TORQUE UNITS button until the desired input unit for TSC1 is reached.
6. Press SHIFT. The display should appear as follows:

POWER	TORQUE	SPEED	STATUS
TSC2	SCALE FACTOR	MAX TORQUE	
TM2XX	00000 Nm/V	00000 XX	
BRAKE STATUS	SET POINT	SET POINT	P I D

Figure 3–11 Torque Transducer Setup Menu

7. Press TORQUE UNITS button and use UP ◀ and DOWN ▶ buttons and Decrease/Increase dial to set desired scale factor for TSC2.
8. Press SHIFT 3 times to return to the main menu.
9. To display the TSC2 torque transducer information in the main menu STATUS area, press SHIFT, AUX SETUP and the POWER UNITS button until the display says ON (as shown in Figure 3–12 Aux Setup Menu - Display On).

POWER	TORQUE	SPEED	STATUS
DISPLAY	TORQUE DAC	SPEED DAC	
ON	0.000 UNITS/V	0000 RPM/V	
BRAKE STATUS	SET POINT	SET POINT	P I D

Figure 3–12 Aux Setup Menu - Display On

10. Press SHIFT to complete the initial setup and return to the new main menu. The display should appear as follows:

POWER	TORQUE	SPEED	STATUS
0.000 HP	±000.0 XX.XX	0	±000.0 Nm
XXX	0.000		00% 00% 00%
BRAKE STATUS	SET POINT	SET POINT	P I D

Figure 3–13 TSC1 with TM2XX Output Menu

SETUP

3.2.4 HYSTERESIS DYNAMOMETER WITH AUXILIARY INSTRUMENTATION SETUP

3.2.4.1 Hardware Connection

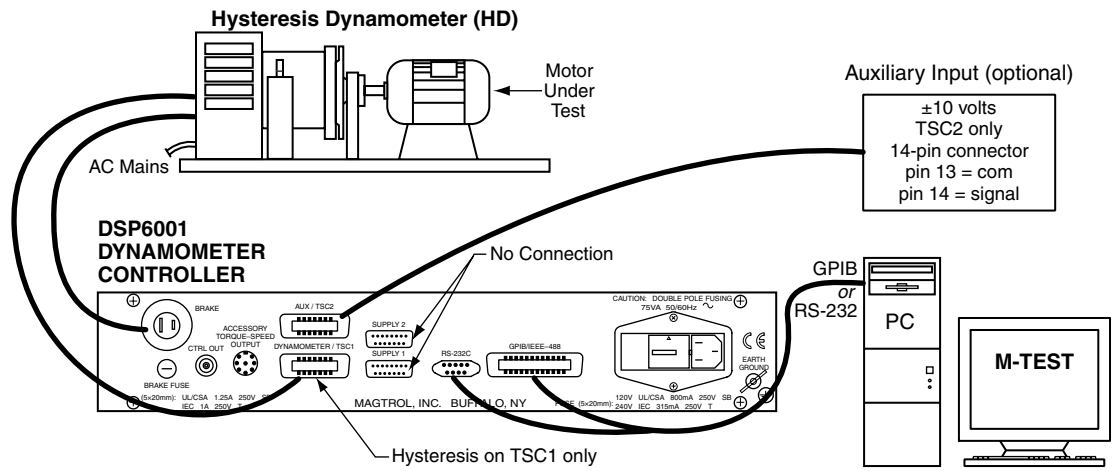

Figure 3–14 Hysteresis Dynamometer with Auxiliary Instrumentation Setup

SETUP

3.2.4.2 Software Configuration

1. Turn on the DSP6001 and proceed to the dynamometer configuration menu. *See Section 3.2.1 – Dynamometer Configuration Menu.*
2. Select TSC1 until HD is reached.
3. Select TSC2 until AUX is reached.
4. Press SHIFT to get to the hysteresis setup menu. *See Figure 3–9 Hysteresis Setup Menu.*
5. Press TORQUE UNITS button until the desired input unit for TSC1 is reached.
6. Press SHIFT. The display should appear as follows:

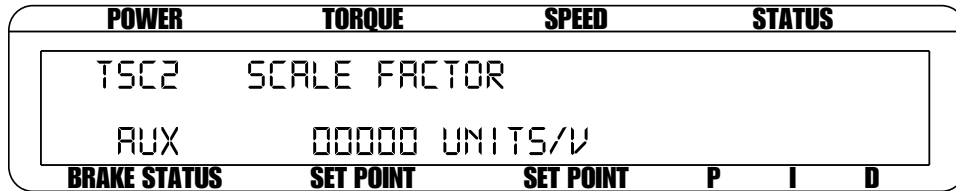

Figure 3–15 TSC2 Aux Setup Menu

7. Press TORQUE UNITS button and use UP ◀ and DOWN ▶ buttons and Decrease/Increase dial to set desired scale factor for TSC2.
8. Press SHIFT 3 times to return to the main menu.
9. To display the TSC2 auxiliary information in the main menu STATUS area, press SHIFT, AUX SETUP and the POWER UNITS button until the display says ON. *See Figure 3–12 Aux Setup Menu - Display On.*
10. Press SHIFT to complete the initial setup and return to the new main menu. The display should appear as follows:

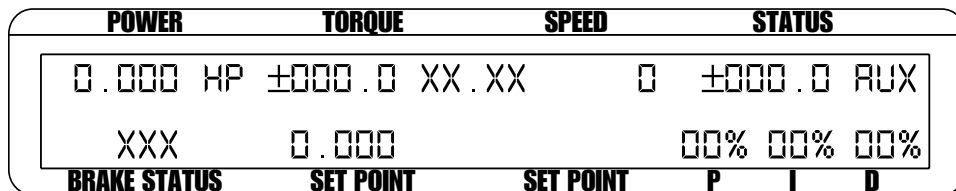

Figure 3–16 TSC1 with AUX Output Menu

SETUP

3.2.5 HYSTERESIS DYNAMOMETER WITH EDDY-CURRENT OR POWDER BRAKE SETUP

3.2.5.1 Hardware Connection

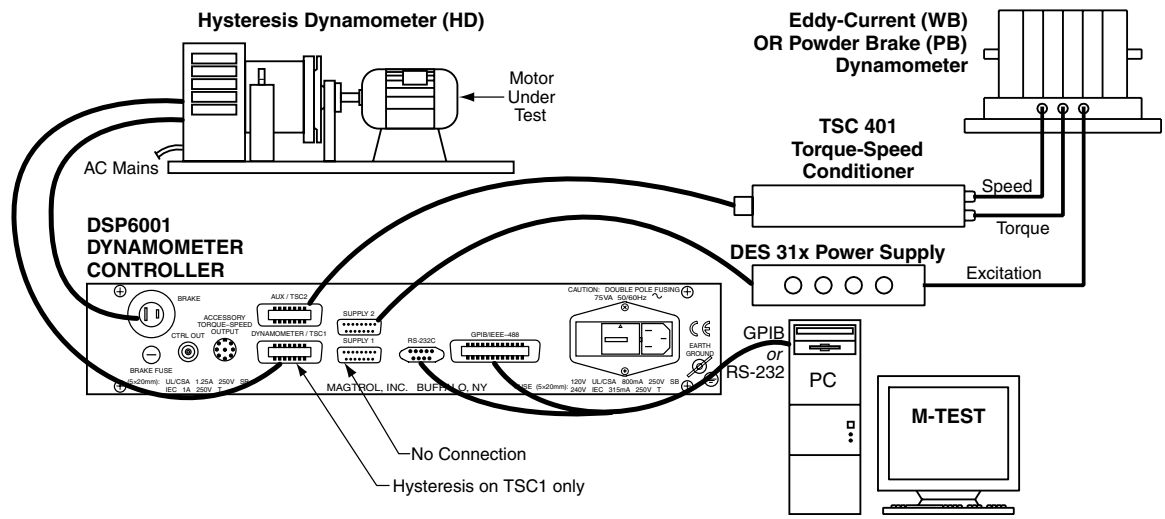

Figure 3–17 Hysteresis Dynamometer with Eddy-Current or Powder Brake Setup

3.2.5.2 Software Configuration

1. Turn on the DSP6001 and proceed to the dynamometer configuration menu. See *Section 3.2.1 – Dynamometer Configuration Menu*.
2. Select TSC1 until HD is reached.
3. Select TSC2 until WB or PB is reached.
4. Press SHIFT to get to the hysteresis setup menu. See *Figure 3–9 Hysteresis Setup Menu*.
5. Press TORQUE UNITS button until the desired input unit for TSC1 is reached.
6. Press SHIFT. The display should appear as follows:

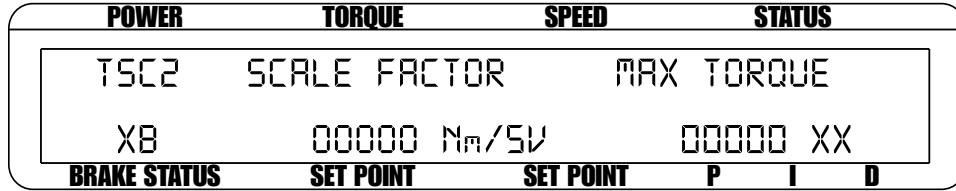

Figure 3–18 TSC2 Eddy-Current/Powder Brake Setup Menu

7. Press TORQUE UNITS button and use UP ◀ and DOWN ▶ buttons and Decrease/Increase dial to set desired scale factor for TSC2.
- 8.a. If using an Eddy Current Dynamometer, press SHIFT 2 times. The display should appear as follows:

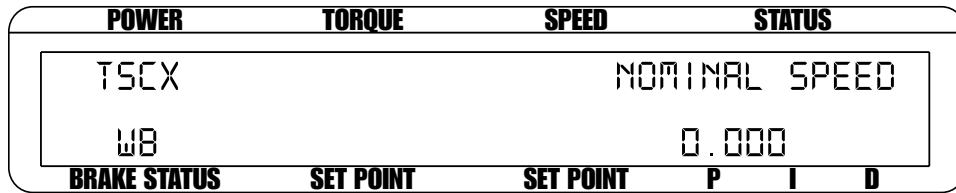

Figure 3–19 Nominal Speed Setup Menu

Press the AUX SETUP button and use UP ◀ and DOWN ▶ buttons and Decrease/Increase dial to set desired nominal speed. Press SHIFT 3 times to complete the initial setup and return to the main menu.

- 8.b. If using a Powder Brake Dynamometer, press SHIFT 3 times to complete the initial setup and return to the main menu.

SETUP

3.2.6 EDDY-CURRENT OR POWDER BRAKE DYNAMOMETER SETUP

3.2.6.1 Hardware Connection

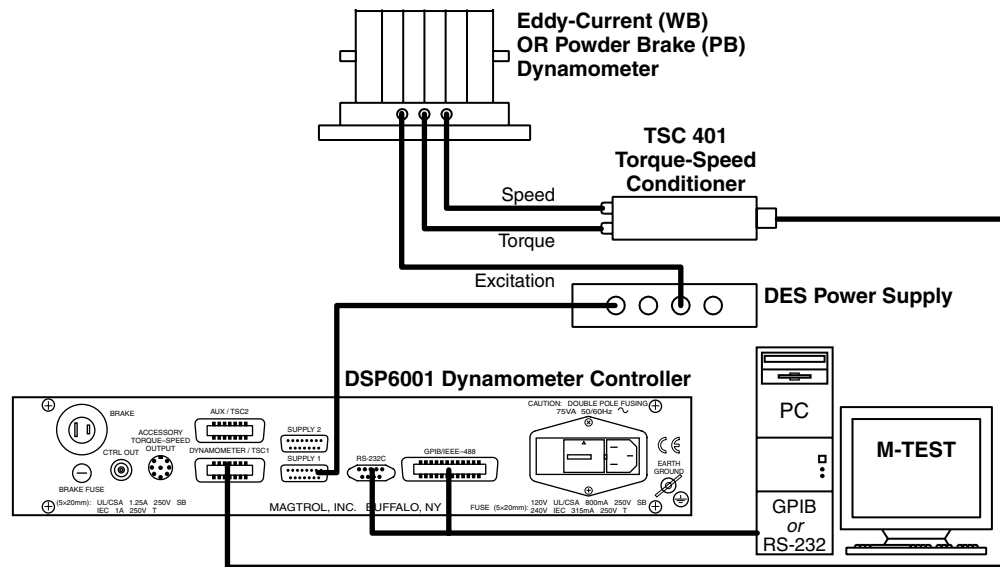

Figure 3–20 Eddy-Current or Powder Brake Dynamometer Setup

3.2.6.2 Software Configuration

1. Turn on the DSP6001 and proceed to the dynamometer configuration menu. See Section 3.2.1 – Dynamometer Configuration Menu.
2. Select TSC1 until WB or PB is reached.
3. Select TSC2 until AUX is reached.
4. Press SHIFT. The display should appear as follows:

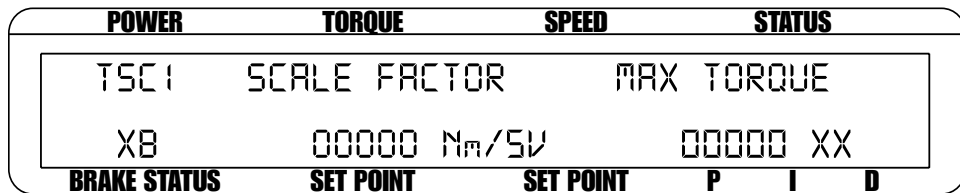

Figure 3–21 TSC1 Eddy-Current/Powder Brake Setup Menu

5. Press TORQUE UNITS button and use UP ◀ and DOWN ▶ buttons and Decrease/Increase dial to set desired scale factor.
- 6.a. If using an Eddy Current Dynamometer, press SHIFT 2 times. The display should appear as shown in Figure 3–19 Nominal Speed Setup Menu. Press the AUX SETUP button and use UP ◀ and DOWN ▶ buttons and Decrease/Increase dial to set desired nominal speed. Press SHIFT 4 times to complete the initial setup and return to the main menu.
- 6.b. If using a Powder Brake Dynamometer, press SHIFT 4 times to complete the initial setup and return to the main menu.

SETUP

3.2.7 EDDY-CURRENT OR POWDER BRAKE DYNAMOMETER WITH TORQUE TRANSDUCER SETUP

3.2.7.1 Hardware Connection

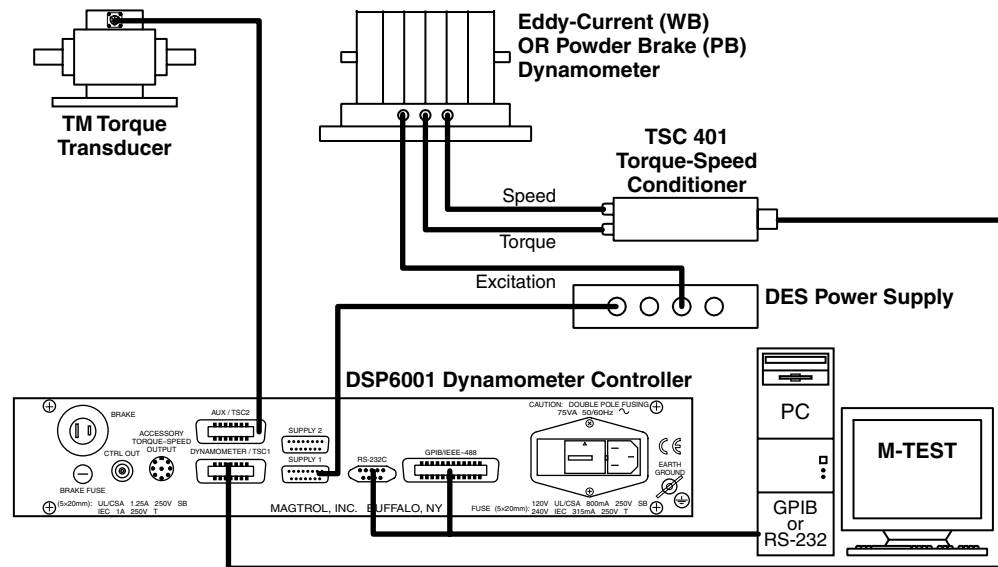

Figure 3–22 Eddy-Current or Powder Brake Dynamometer with Torque Transducer Setup

3.2.7.2 Software Configuration

1. Turn on the DSP6001 and proceed to the dynamometer configuration menu. See Section 3.2.1 – Dynamometer Configuration Menu.
2. Select TSC1 until WB or PB is reached.
3. Select TSC2 until TM2XX is reached.
4. Press SHIFT to get to the TSC1 eddy-current/powder brake setup menu. See Figure 3–21 TSC1 Eddy-Current/Powder Brake Setup Menu.
5. Press TORQUE UNITS button and use UP ◀ and DOWN ▶ buttons and Decrease/Increase dial to set desired scale factor for TSC1.
- 6.a. If using an Eddy Current Dynamometer, press SHIFT 2 times. The display should appear as shown in Figure 3–19 Nominal Speed Setup Menu. Press the AUX SETUP button and use UP ◀ and DOWN ▶ buttons and Decrease/Increase dial to set desired nominal speed. Press SHIFT 2 times to get to the Torque Transducer Setup Menu as shown in Figure 3–11.
- 6.b. If using a Powder Brake Dynamometer, press SHIFT 2 times to get to the Torque Transducer Setup Menu as shown in Figure 3–11.
7. Press TORQUE UNITS button and use UP ◀ and DOWN ▶ buttons and Decrease/Increase dial to set desired scale factor for TSC2.
8. Press SHIFT 3 times to return to the main menu.
9. To display the TSC2 torque transducer information in the main menu STATUS area, press SHIFT, AUX SETUP and the POWER UNITS button until the display says ON. See Figure 3–12 Aux Setup Menu - Display On.
10. Press SHIFT to complete the initial setup and return to the new main menu. See Figure 3–13 TSC1 with TM2XX Output Menu.

3.2.8 EDDY-CURRENT OR POWDER BRAKE DYNAMOMETER WITH AUXILIARY INSTRUMENTATION SETUP

3.2.8.1 Hardware Connection

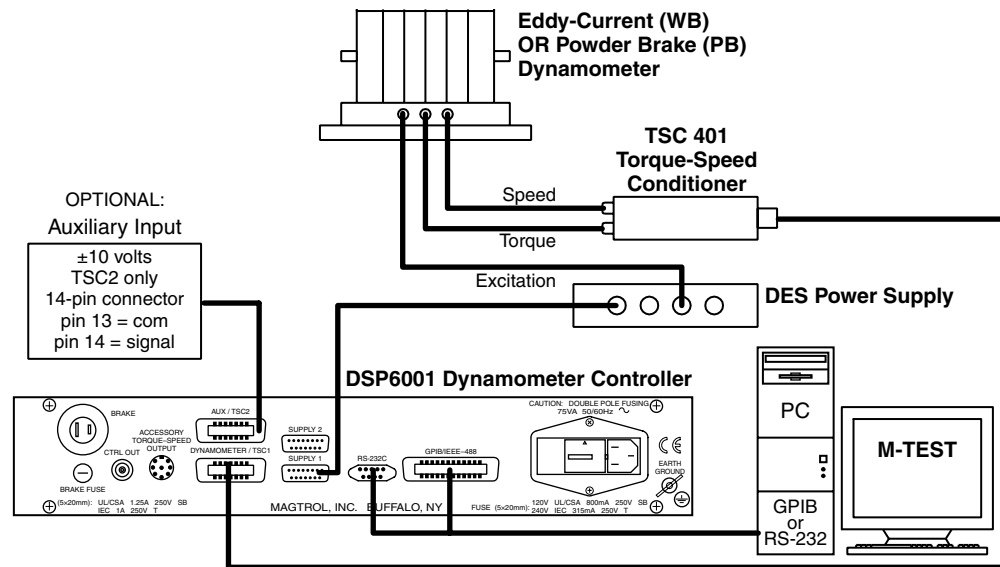

Figure 3–23 Eddy-Current or Powder Brake Dynamometer with Auxiliary Instrumentation Setup

3.2.8.2 Software Configuration

1. Turn on the DSP6001 and proceed to the dynamometer configuration menu. See *Section 3.2.1 – Dynamometer Configuration Menu*.
2. Select TSC1 until WB or PB is reached.
3. Select TSC2 until AUX is reached.
4. Press SHIFT to get to the TSC1 eddy-current/powder brake setup menu. See *Figure 3–21 TSC1 Eddy-Current/Powder Brake Setup Menu*.
5. Press TORQUE UNITS button and use UP ◀ and DOWN ▶ buttons and Decrease/Increase dial to set desired scale factor for TSC1.
- 6.a. If using an Eddy Current Dynamometer, press SHIFT 2 times. The display should appear as shown in *Figure 3–19 Nominal Speed Setup Menu*. Press the AUX SETUP button and use UP ◀ and DOWN ▶ buttons and Decrease/Increase dial to set desired nominal speed. Press SHIFT 2 times to get to the Auxiliary Instrumentation Setup Menu as shown in *Figure 3–15*.
- 6.b. If using a Powder Brake Dynamometer, press SHIFT 2 times to get to the Auxiliary Instrumentation Setup Menu as shown in *Figure 3-15*.
7. Press TORQUE UNITS button and use UP ◀ and DOWN ▶ buttons and Decrease/Increase dial to set desired scale factor for TSC2.
8. Press SHIFT 3 times to return to the main menu.
9. To display the TSC2 auxiliary information in the main menu STATUS area, press SHIFT, AUX SETUP and the POWER UNITS button until the display says ON. See *Figure 3–13 Aux Setup Menu - Display On*.
10. Press SHIFT to complete the initial setup and return to the new main menu. See *Figure 3–16 TSC1 with AUX Output Menu*.

3.2.9 TWO EDDY-CURRENT/POWDER BRAKE DYNAMOMETERS (INDEPENDENT SETUP)

3.2.9.1 Hardware Connection

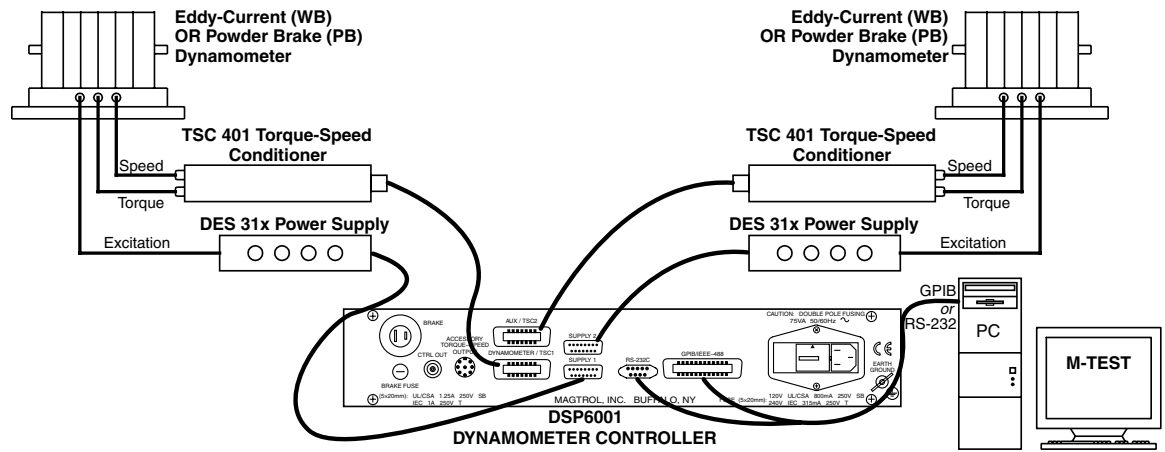

Figure 3–24 Two Eddy-Current/Powder Brake Dynamometers (Independent Setup)

3.2.9.2 Software Configuration

1. Turn on the DSP6001 and proceed to the dynamometer configuration menu. See *Section 3.2.1 – Dynamometer Configuration Menu*.
2. Select TSC1 until WB or PB is reached.
3. Select TSC2 until WB or PB is reached.
4. Press SHIFT to get to the TSC1 eddy-current/powder brake setup menu. See *Figure 3–21 TSC1 Eddy-Current/Powder Brake Setup Menu*.
5. Press TORQUE UNITS button and use UP ◀ and DOWN ▶ buttons and Decrease/Increase dial to set desired scale factor for TSC1.
- 6.a. If using an Eddy Current Dynamometer, press SHIFT 2 times. The display should appear as shown in *Figure 3–19 Nominal Speed Setup Menu*. Press the AUX SETUP button and use UP ◀ and DOWN ▶ buttons and Decrease/Increase dial to set desired nominal speed. Press SHIFT 2 times to get to the TSC2 Eddy-Current/Powder Brake Setup Menu as shown in *Figure 3–18*.
- 6.b. If using a Powder Brake Dynamometer, press SHIFT 2 times to get to the TSC2 Eddy-Current/Powder Brake Setup Menu as shown in *Figure 3–18*.
7. Press TORQUE UNITS button and use UP ◀ and DOWN ▶ buttons and Decrease/Increase dial to set desired scale factor for TSC2.
- 8.a. If using an Eddy Current Dynamometer, press SHIFT 2 times. The display should appear as shown in *Figure 3–19 Nominal Speed Setup Menu*. Press the AUX SETUP button and use UP ◀ and DOWN ▶ buttons and Decrease/Increase dial to set desired nominal speed. Press SHIFT 2 times.
- 8.b. If using a Powder Brake Dynamometer, Press SHIFT 2 times.
9. The menu will appear as follows:

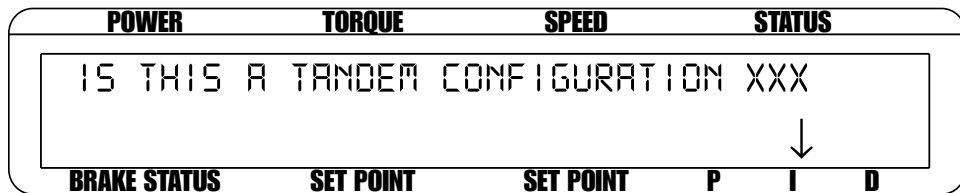

Figure 3–25 Tandem Configuration Menu

10. Press the COM SETUP button until the menu says “NO”.
11. Press SHIFT 2 times to complete the initial setup and return to the main menu.

3.2.10 Two EDDY-CURRENT/POWDER BRAKE DYNAMOMETERS (TANDEM SETUP)

3.2.10.1 Hardware Connection

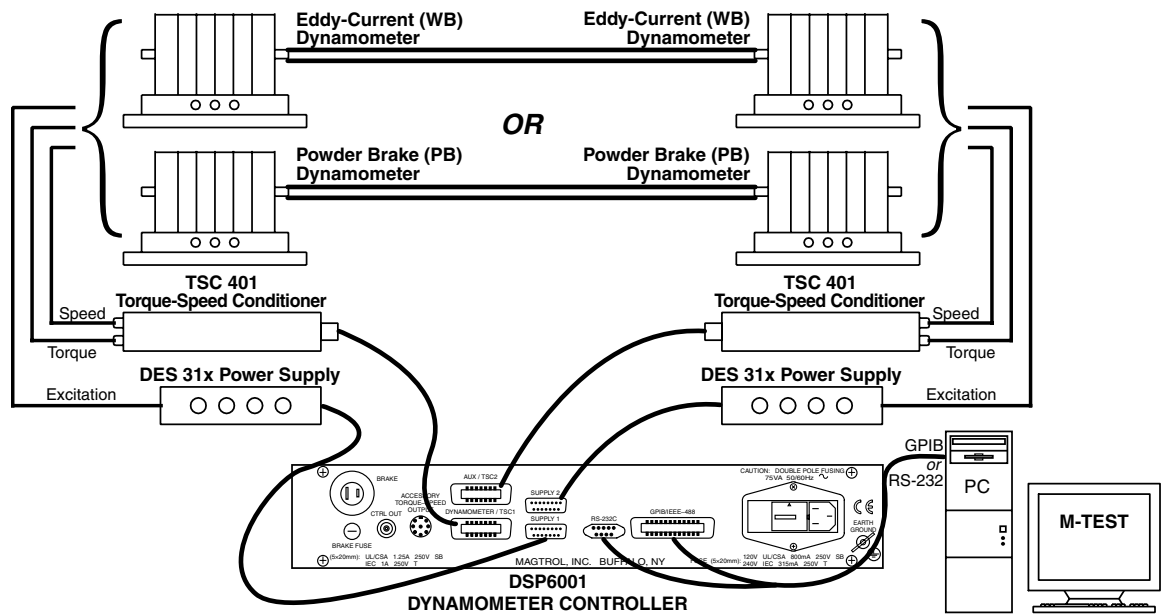

Figure 3-26 Two Eddy-Current/Powder Brake Dynamometers (Tandem Setup)



Note: This particular tandem configuration is only applicable to a WB-WB or PB-PB combination.

3.2.10.2 Software Configuration

1. Turn on the DSP6001 and proceed to the dynamometer configuration menu. See *Section 3.2.1 – Dynamometer Configuration Menu*.
2. Select TSC1 until WB or PB is reached.
3. Select TSC2 until WB or PB is reached.
4. Press SHIFT to get to the TSC1 eddy-current/powder brake setup menu. See *Figure 3–21 TSC1 Eddy-Current/Powder Brake Setup Menu*.
5. Press TORQUE UNITS button and use UP ◀ and DOWN ▶ buttons and Decrease/Increase dial to set desired scale factor for TSC1.
- 6.a. If using an Eddy Current Dynamometer, press SHIFT 2 times. The display should appear as shown in *Figure 3–19 Nominal Speed Setup Menu*. Press the AUX SETUP button and use UP ◀ and DOWN ▶ buttons and Decrease/Increase dial to set desired nominal speed. Press SHIFT 2 times to get to the TSC2 Eddy-Current/Powder Brake Setup Menu as shown in *Figure 3–18*.
- 6.b. If using a Powder Brake Dynamometer, press SHIFT 2 times to get to the TSC2 Eddy-Current/Powder Brake Setup Menu as shown in *Figure 3–18*.
7. Press TORQUE UNITS button and use UP ◀ and DOWN ▶ buttons and Decrease/Increase dial to set desired scale factor for TSC2.
- 8.a. If using an Eddy Current Dynamometer, press SHIFT 2 times. The display should appear as shown in *Figure 3–19 Nominal Speed Setup Menu*. Press the AUX SETUP button and use UP ◀ and DOWN ▶ buttons and Decrease/Increase dial to set desired nominal speed. Press SHIFT 2 times.
- 8.b. If using a Powder Brake Dynamometer, Press SHIFT 2 times.
9. The Tandem Configuration Menu will appear as shown in *Figure 3–25*.
10. Press the COM SETUP button until the menu says “YES”.
11. Press SHIFT 2 times to complete the initial setup and return to the main menu.

3.2.11 EDDY-CURRENT DYNAMOMETER WITH POWDER BRAKE DYNAMOMETER (TANDEM SETUP)

3.2.11.1 Hardware Connection

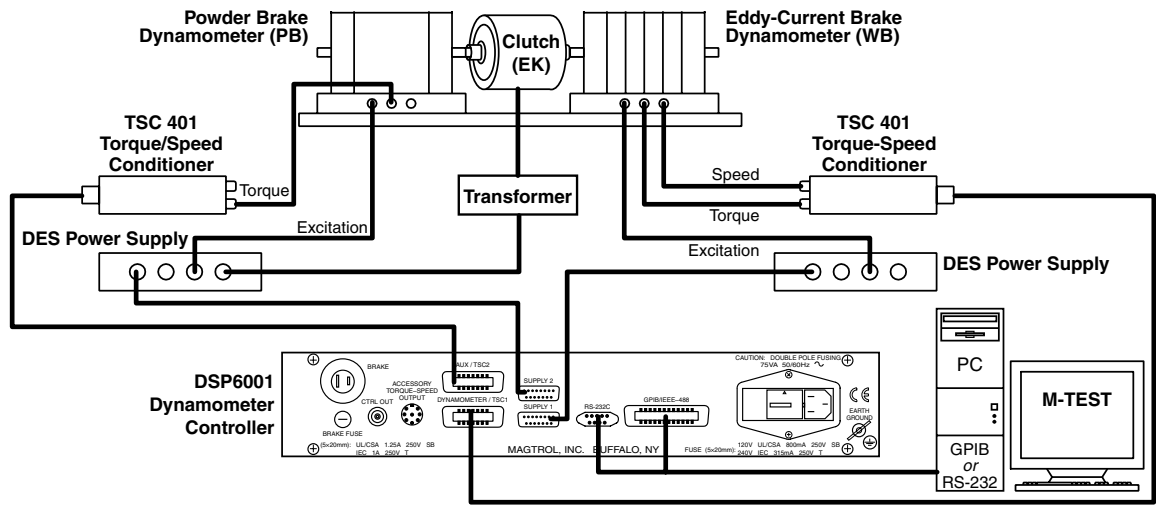

Figure 3–27 Eddy-Current Dynamometer with Powder Brake Dynamometer (Tandem Setup)

3.2.11.2 Software Configuration

1. Turn on the DSP6001 and proceed to the dynamometer configuration menu. See Section 3.2.1 – Dynamometer Configuration Menu.
2. Select TSC1 until WB is reached.
3. Select TSC2 until PB is reached.
4. Press SHIFT to get to the TSC1 Eddy-Current Setup Menu as seen below.

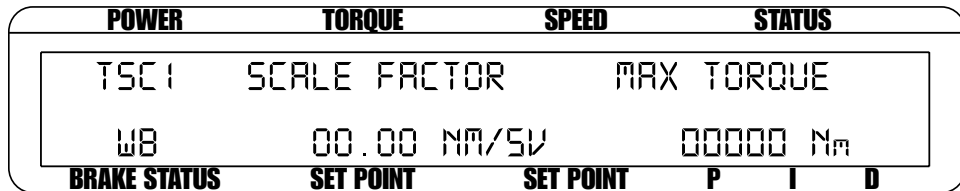

Figure 3–28 TSC1 Eddy-Current Setup Menu

5. Press TORQUE UNITS button and use UP ◀ and DOWN ▶ buttons and Decrease/Increase dial to set desired scale factor for TSC1.
6. Press SHIFT 2 times. The display should appear as shown in Figure 3–19 Nominal Speed Setup Menu.
7. Press the AUX SETUP button and use UP ◀ and DOWN ▶ buttons and Decrease/Increase dial to set desired nominal speed.

SETUP

8. Press SHIFT 2 times to get to the TSC2 Powder Brake Setup Menu as shown below.

POWER	TORQUE	SPEED	STATUS
TSC2	SCALE FACTOR	MAX TORQUE	
PB	00.00 NM/SV	00000 Nm	
BRAKE STATUS	SET POINT	SET POINT	P I D

Figure 3–29 TSC2 Powder Brake Setup Menu

9. Press TORQUE UNITS button and use UP ◀ and DOWN ▶ buttons and Decrease/Increase dial to set desired scale factor for TSC2.
10. Press SHIFT 2 times. The menu will appear as shown in *Figure 3–25 Tandem Configuration Menu*.
11. Press the COM SETUP button until the menu says “YES”.
12. Press SHIFT once to reach the Maximum Speed Excited Menu as shown below.

POWER	TORQUE	SPEED	STATUS
MAXIMUM SPEED EXCITED OF PB			
{CLUTCH DEACTIVATION}		00000	
BRAKE STATUS	SET POINT	SET POINT	P I D

Figure 3–30 Maximum Speed Excited Menu

13. Press the AUX SETUP button and use UP ◀ and DOWN ▶ buttons and Decrease/Increase dial to set maximum speed excited of PB.
14. Press SHIFT 3 times to complete initial setup and return to the main menu.

3.2.12 IN-LINE TORQUE TRANSDUCER CROSS LOOP FUNCTION

3.2.12.1 Hardware Connection

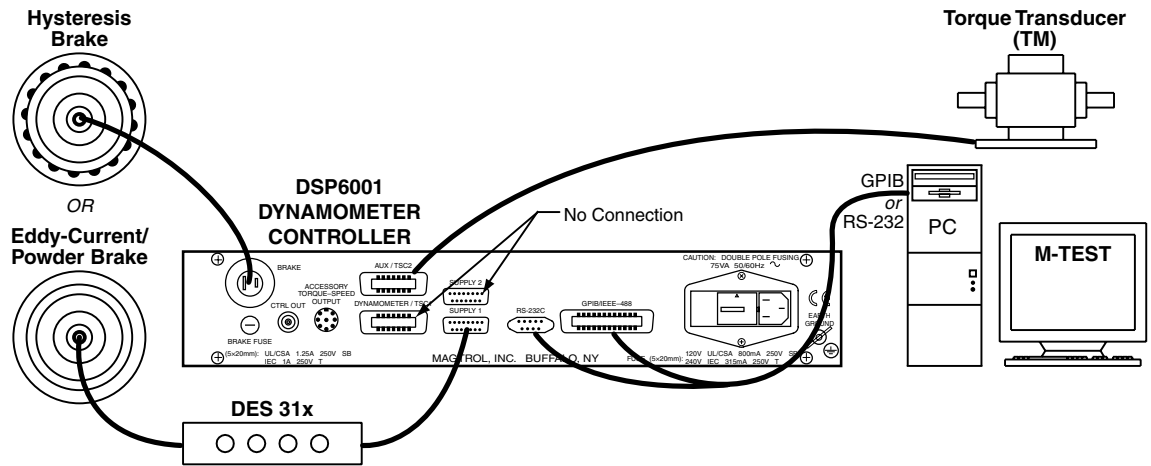

Figure 3-31 In-Line Torque Transducer Cross Loop Function



Note: In the Torque Transducer Cross Loop Function, the TM2XX is connected to TSC2 while controlling the outputs of TSC1. The connection allows closed loop control of a brake via the Torque Transducer.

3.2.12.2 Software Configuration

1. Turn on the DSP6001 and proceed to the dynamometer configuration menu. See Section 3.2.1 – Dynamometer Configuration Menu.
2. Select TSC1 until BRAKE is reached.
3. Select TSC2 until TM2XX is reached.
4. Press SHIFT to get to the Torque Transducer Setup Menu as shown in Figure 3-11.
5. Press TORQUE UNITS button and use UP ◀ and DOWN ▶ buttons and Decrease/Increase dial to set desired scale factor for TSC2.
6. Press SHIFT 2 times to reach the Brake Type menu as seen below.

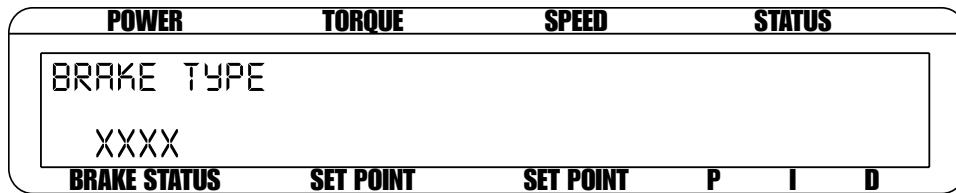

Figure 3-32 Brake Type Menu

7. Press POWER UNITS button until desired Brake Type is reached.

SETUP

- 8.a. If choosing a Hysteresis or Powder Brake Type, press SHIFT 2 times to complete setup and return to main menu.
- 8.b. If choosing an Eddy-Current Brake Type, menu will appear as follows:

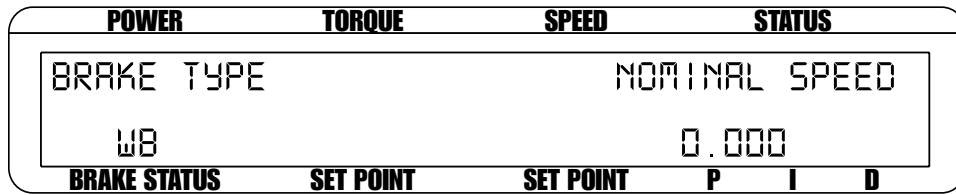

Figure 3–33 Brake Type Menu (for WB)

Press AUX SETUP button and use UP ◀ and DOWN ▶ buttons and Decrease/Increase dial to set nominal speed. Then press SHIFT 3 times to complete setup and return to main menu.

3.3 SPEED ENCODER SETUP

1. Starting from main menu, press SHIFT.
2. Press DYNO SETUP.
3. Select ENCODERS. The display should appear as follows:

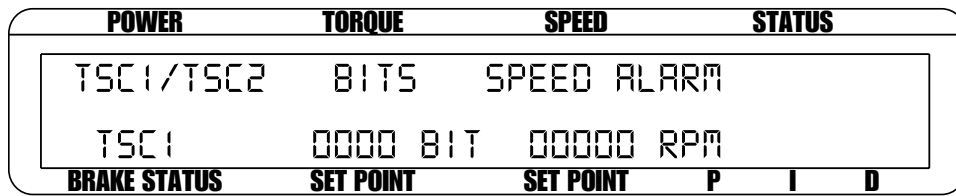

Figure 3–34 Encoder Menu

4. Press TORQUE UNITS button until the desired bit selection for TSC1 is reached.
5. To set bits for TSC2, press POWER UNITS button once, then press TORQUE UNITS button until the desired bit selection is reached.
6. Press SHIFT 2 times to complete SPEED ENCODER setup and return to the main menu.

3.3.1 BIT CONFIGURATIONS

Standard bit configurations are as follows:

Test Instrument	Encoder
Hysteresis Dynamometer	60 bit*
Eddy-Current Dynamometer	20, 30 and 60 bit*
Powder Brake Dynamometer	20, 30 and 60 bit*
In-Line Torque Transducer	30 bit

* 600 and 6000 bit also available

SETUP

3.4 TORQUE/SPEED ANALOG OUTPUTS

Torque and Speed DAC Outputs provide an analog output proportional to the torque and speed of the system. They are available on the Accessory Torque-Speed Output Connector (as seen in *Figure 2–6 Accessory Torque-Speed Output*) and are updated every 2 milliseconds. Both of the outputs have a user definable Scale Factor found under the SHIFT/AUX SETUP key sequence.

3.4.1 TORQUE DAC SCALE FACTOR

Torque DAC Scale Factor is scaled in displayed torque units/volt.

Example:

If the displayed torque units are set to oz.in. and the Torque DAC scale is set to 1 unit/volt, then 1 oz.in. will result in 1 volt at the torque output.

3.4.2 SPEED DAC SCALE FACTOR

Speed DAC Scale Factor is scaled in rpm/volt.

Example:

If the Speed DAC scale is set to 1000 rpm/volt, then 1000 rpm will result in 1 volt at the speed output.

3.4.3 TORQUE/SPEED DAC SETUP

1. Starting from main menu, press SHIFT.
2. Press AUX SETUP. The display should appear as follows:

POWER	TORQUE	SPEED	STATUS
XXXXXXXX	TORQUE DAC	SPEED DAC	
XXX	0.000 UNITS/V	0000	RPM/V
BRAKE STATUS	SET POINT	SET POINT	P I D

Figure 3–35 Torque/Speed DAC Setup Menu

3. Press TORQUE UNITS button and use UP ◀ and DOWN ▶ buttons and Decrease/Increase dial to set desired Torque DAC value.
4. Press SHIFT.
5. Press AUX SETUP button and use UP ◀ and DOWN ▶ buttons and Decrease/Increase dial to set desired Speed DAC value.
6. Press SHIFT two times to return to main menu.

SETUP

4. Digital Filters

The Digital Filters of the DSP6001 are used to remove undesired noise from the TSC inputs. This noise could be conducted from an undesired measured signal such as mechanical vibration or other electrical sources.

4.1 FILTER PARAMETERS

The input to the A/D converter internal to the DSP6001 has a traditional analog filter that is comprised of the following characteristics:

- -3db Point: 3.8 KHz
- A/D Sample Rate: 7812.5 KHz
- 16 Acquired and Averaged Samples: Average applied to filter at a rate of 488.28125 Hz
- Filter Cutoff Frequencies: 3 Hz, 10 Hz, 25 Hz, 50 Hz
- Filter Output: Equivalent to second order Butterworth analog filter
- Transposed Direct Form II Architecture: The diagram below shows this architecture.

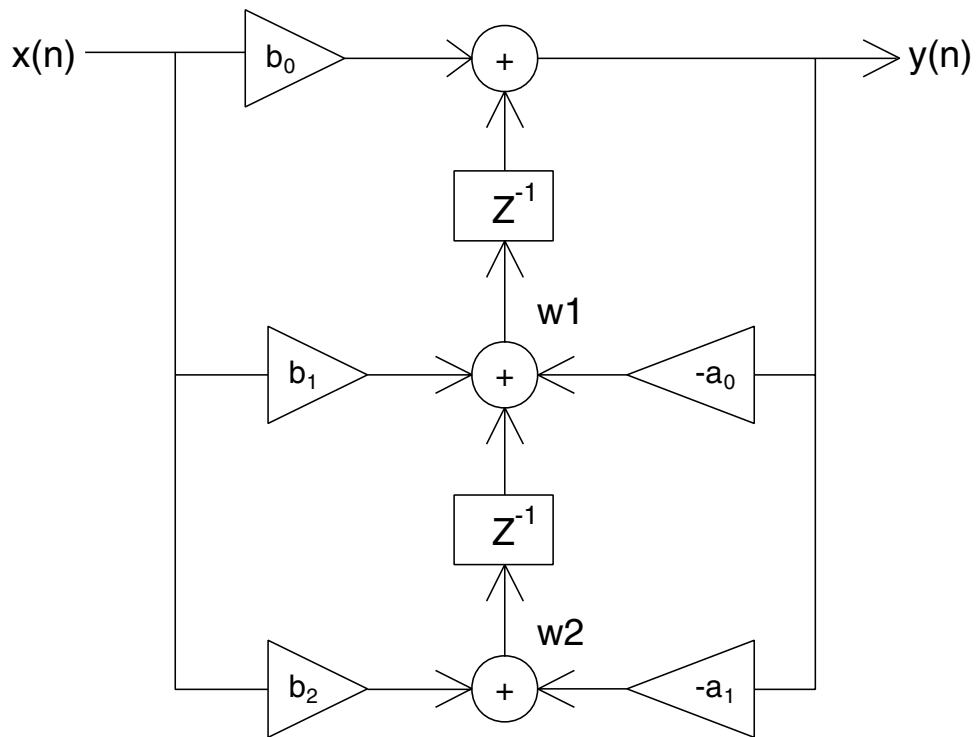

Figure 4-1 Transposed Direct Form II Architecture

With a Digital Filter, the DSP6001 is able to solve the following equations:

$$\begin{aligned} y(n) &= b_0 * x(n) + w1 \\ w1 &= b_1 * x(n) + a1 * y(n) + w2 \\ w2 &= b_2 * x(n) + a2 * y(n) \end{aligned}$$

The equations are applicable to each channel, occurring every 2.48 milliseconds.

4.2 FILTER SETUP



Filter setup should take place after hardware installation and software configuration of the chosen testing instruments has been completed. *See Chapter 3 – Installation/Configuration.*

There are four different Filter settings to choose from including 10 Hz, 25 Hz, 50 Hz and OFF. The following instructions show how to select the desired Filter for each channel:

1. Starting from the main menu, press SHIFT.
2. Press DYNO SETUP button.
3. Select DYNAMOMETER.
4. Press TORQUE UNITS button until the desired TSC1 Filter setting is reached.
5. Press COM SETUP button until the desired TSC2 Filter setting is reached.
6. Press SHIFT repeatedly until the main menu is reached. The number of times will vary depending on testing instrument selection.

5. PID Settings

5.1 ABOUT THE PID LOOP

The DSP6001 has PID adjustment capability for both the speed and torque modes to provide the best system response. The PID Loop comprises the following three variables:

- P = proportional gain
- I = integral
- D = derivative

Other important variables include:

- Set point - desired load or speed
- Error - difference between the set point and the actual measurement

5.1.1 P (PROPORTIONAL GAIN)

With proportional gain, the controller output is proportional to the error or to a change in measurement. Deviation from the set point is usually present. Increasing the proportional gain will make the PID loop unstable. Increasing the integral value will eliminate this instability. For best loop control, set the proportional gain as high as possible without causing the loop to become unstable.

5.1.2 I (INTEGRAL)

With integral, the controller output is proportional to the amount of time the error is present. Increasing the integral value eliminates the offset from the set point. If the response becomes oscillatory increase the derivative value.

5.1.3 D (DERIVATIVE)

With derivative, the controller output is proportional to the rate of change of measurement or error. Derivative can compensate for a changing measurement. Derivative takes action to inhibit more rapid changes of the measurement than proportional gain.

5.2 SETTING PID VALUES

5.2.1 HOW TO SET P (PROPORTIONAL GAIN) VALUE

1. Starting at the main menu press the P button.
2. Use the Decrease/Increase dial until the desired percentage is reached (ranges from 0-99).

5.2.2 HOW TO SET I (INTEGRAL) VALUE

1. Starting at the main menu press the I button.
2. Use the Decrease/Increase dial until the desired percentage is reached (ranges from 0-99).

5.2.3 HOW TO SET D (DERIVATIVE) VALUE

1. Starting at the main menu press the D button.
2. Use the Decrease/Increase dial until the desired percentage is reached (ranges from 0-99).

5.3 HOW THE PID LOOP WORKS

The following diagram demonstrates the correlation between the variables in the PID LoOp.

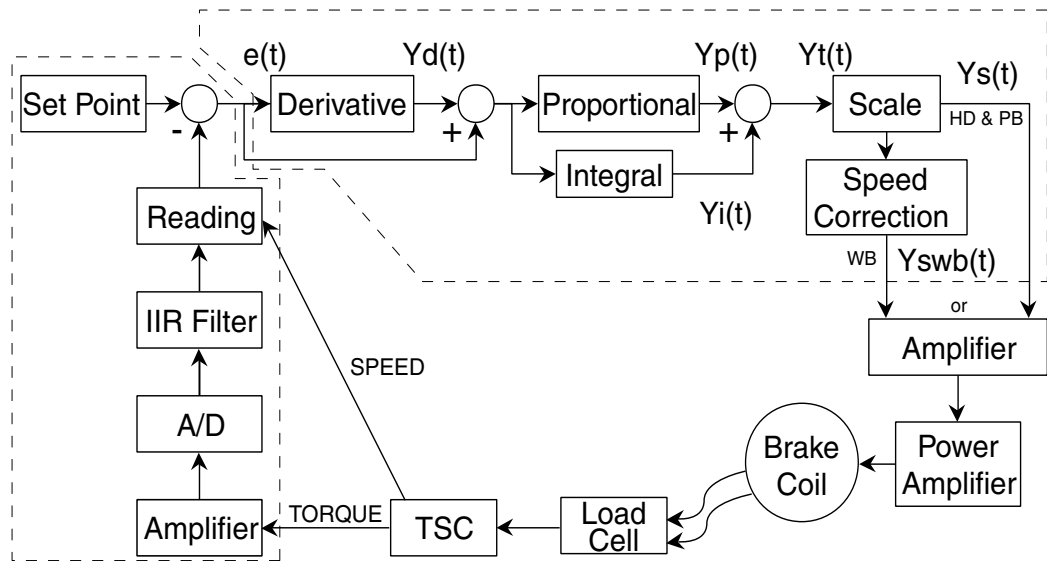

Figure 5-1 System Block Diagram

SETUP

5.3.1 SCALE FACTORS FOR HYSTERESIS, EDDY-CURRENT AND POWDER BRAKE DYNAMOMETERS



TORQUE: TSC1 $Y_s(t) = Y_t(t) / 1.725 * 2$
 TSC2 $Y_s(t) = Y_t(t) / 1.725 * 2 * 1.6623$

SPEED: TSC1 & TSC2 $Y_s(t) = Y_t(t) * 5319.93 / \text{MAX SPEED}$

5.3.2 SPEED CORRECTION FOR WB (EDDY-CURRENT BRAKE) DYNAMOMETER



The WB Dynamometer follows the same scaling as the HYST and PB with the addition of one calculation for both torque and speed. This calculation is due to the fact that for a given current the torque changes with speed. This is referred to as speed correction.

$$Y_{swb}(t) = (Y_s(t) + Y_s(t) / \text{speed correction factor}) / 2$$

The speed correction factor is calculated on each entry into the PID loop equations.

$$\text{Speed Correction Factor} = -0.0001 * x * 2 + 0.0203 * x + 0.005 \text{ limited to } 0.051 \text{ to } 1$$

where $x = \text{RPM} / \text{NOMINAL SPEED} * 100$

NOMINAL SPEED is set by the user and obtained from the data sheets for the dynamometer or brake.

5.3.3 EQUATIONS

Where Skp, Ski and Skd are system coefficients...

$$Y_d(t) = (e(t) - e(t-3) + 3 * (e(t-1) - e(t-2))) * (10/Skd) * D\%$$

$$Y_p(t) = (e(t) + Y_d(t)) * (10/Skp) * P\%$$

$$Y_i(t) = Y_i(t-1) + (e(t) + Y_d(t)) * (10/Ski) * I\%$$

$$Y_t(t) = Y_p(t) + Y_i(t)$$

$$Y_s(t) = \text{Scale} * Y_t(t)$$

5.4 ADDITIONAL SCALE FACTOR

The Additional Scale Factor is a multiplier of the P, I or D term. Due to the fact there are so many different dynamometer types and motor combinations, this multiplier is needed to extend the range of the PID. The letters represent the following:

A = 0.001	F = 0.5
B = 0.005	G = 1
C = 0.01	H = 5
D = 0.05	I = 10
E = 0.1	

In using the multiplier, the user can input PID numbers from 0.001 (.001 x 1%) to 990 (10.0 x 99%) with good resolution.

5.4.1 HOW TO SET ADDITIONAL SCALE FACTOR

Before following the setup instructions, the values that must be set will need to be determined. This will depend on which testing instrument has been chosen for the configuration. For appropriate settings, refer to the guide provided in *Appendix F: Additional Scale Factor Table*. Once the proper settings have been determined, proceed with the following instructions for setup.

5.4.1.1 Setting Additional Scale Factor for P (Proportional Gain)

1. Starting from the main menu, press and hold the P button. While holding the P button, press SHIFT.
2. Use the P button to toggle through the letters in the unit (A, B, C, D, E, F, G, H and I).
3. Choose the letter that corresponds with the pre-determined setting provided in the Additional Scale Factor Table shown in *Appendix F*.
4. Once the letter is chosen, press SHIFT to return to the main menu.

5.4.1.2 Setting Additional Scale Factor for I (Integral)

1. Starting from the main menu, press and hold the I button. While holding the I button, press SHIFT.
2. Use the I button to toggle through the letters in the unit (A, B, C, D, E, F, G, H and I).
3. Choose the letter that corresponds with the pre-determined setting provided in the Additional Scale Factor Table shown in *Appendix F*.
4. Once the letter is chosen, press SHIFT to return to the main menu.

5.4.1.3 Setting Additional Scale Factor for D (Derivative)

1. Starting from the main menu, press and hold the D button. While holding the D button, press SHIFT.
2. Use the D button to toggle through the letters in the unit (A, B, C, D, E, F, G, H and I).
3. Choose the letter that corresponds with the pre-determined setting provided in the Additional Scale Factor Table shown in *Appendix F*.
4. Once the letter is chosen, press SHIFT to return to the main menu.

5.5 SETTING THE CORRECT PID'S FOR YOUR MOTOR



Note: Each type of motor will have its own optimum PID setting at different load points.

5.5.1 SETTING THE PID WITH AN UNKNOWN MOTOR OR SYSTEM

If the user is unfamiliar with the characteristics of the motor under test, it is recommended to begin in Open Loop Control mode. In doing so, the user can safely get an idea of the motor's performance.

1. To enter Open Loop Control mode, begin with the motor and brake OFF. Press and hold the TORQUE SET button until a second beep is heard. The display will appear as follows:

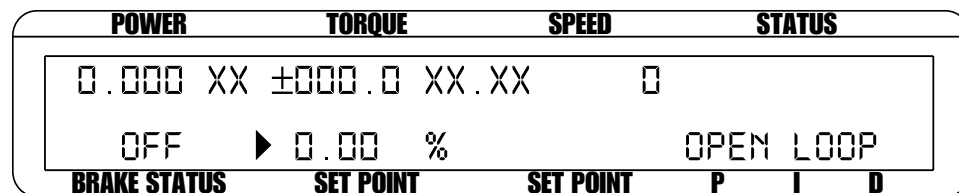

Figure 5-2 Open Loop Control Menu

2. Set the percent excitation to zero.
3. Start the motor.
4. Slowly increase the excitation current to the brake.
5. Make a note of the torque and speed values of which the motor is capable.
6. To exit the Open Loop Control mode and return to the main menu, turn the motor and brake OFF and press and hold the TORQUE SET button until a second beep is heard.

5.5.2 SETTING THE PID FOR TORQUE CONTROL

1. With the motor and brake OFF, set the desired Torque Set Point by pressing the TORQUE SET button and using the UP ◀ and DOWN ▶ buttons and Decrease/Increase dial.
2. Set the P, I and D values to zero.
3. Turn the motor ON.
4. Turn the brake ON.
5. Slowly increase the P term until the torque read is about 25% of the desired load point.

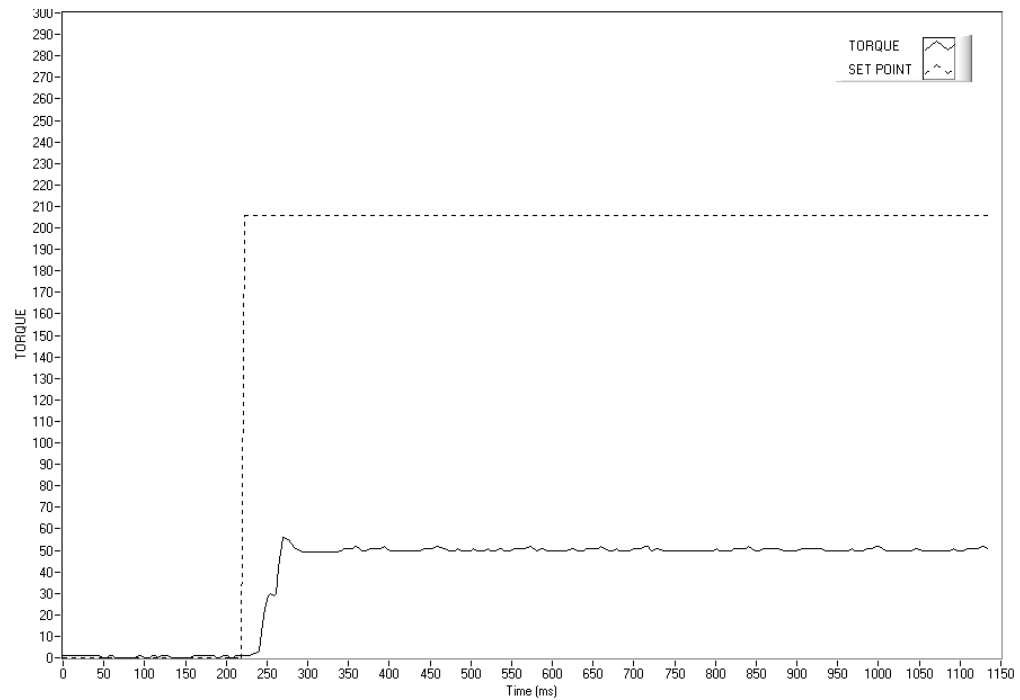

Figure 5-3 Initial P Setting for Torque Control at 25%

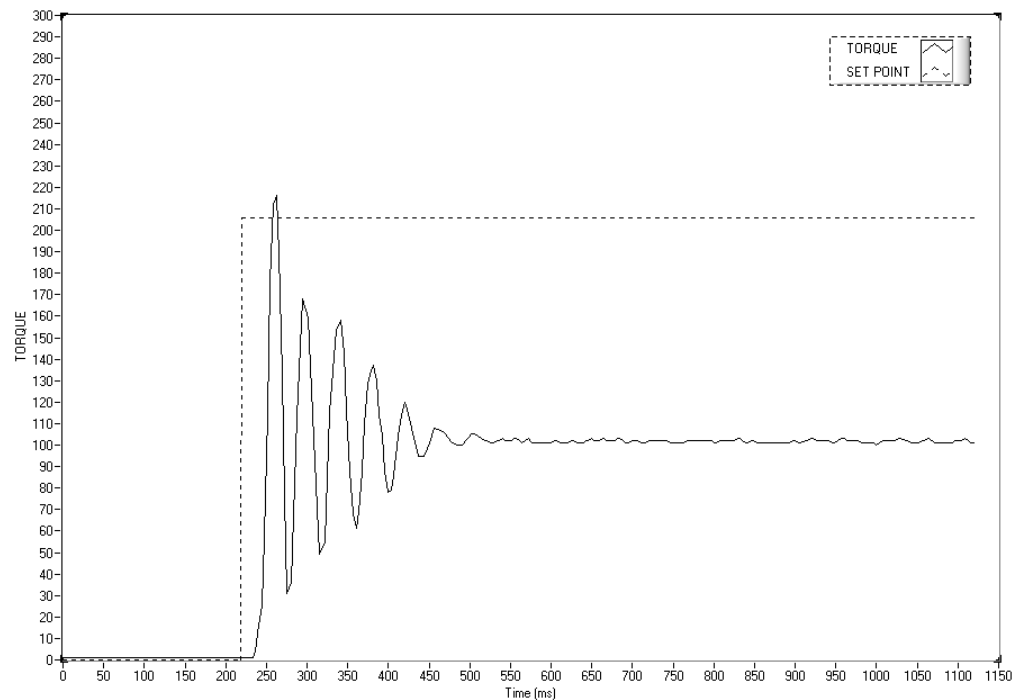

Figure 5-4 High Initial P Setting for Torque Control

6. Turn the brake OFF.
7. Increase the I term to 10%.
8. Turn the brake ON and observe response, then turn the brake OFF. Desired Result is a fast response with some over shoot.

- a. If the response was too slow, increase the I term in 1-5% increments and repeat #8.
- b. If the response was too fast, decrease the I term in 1-5% increments and repeat #8.

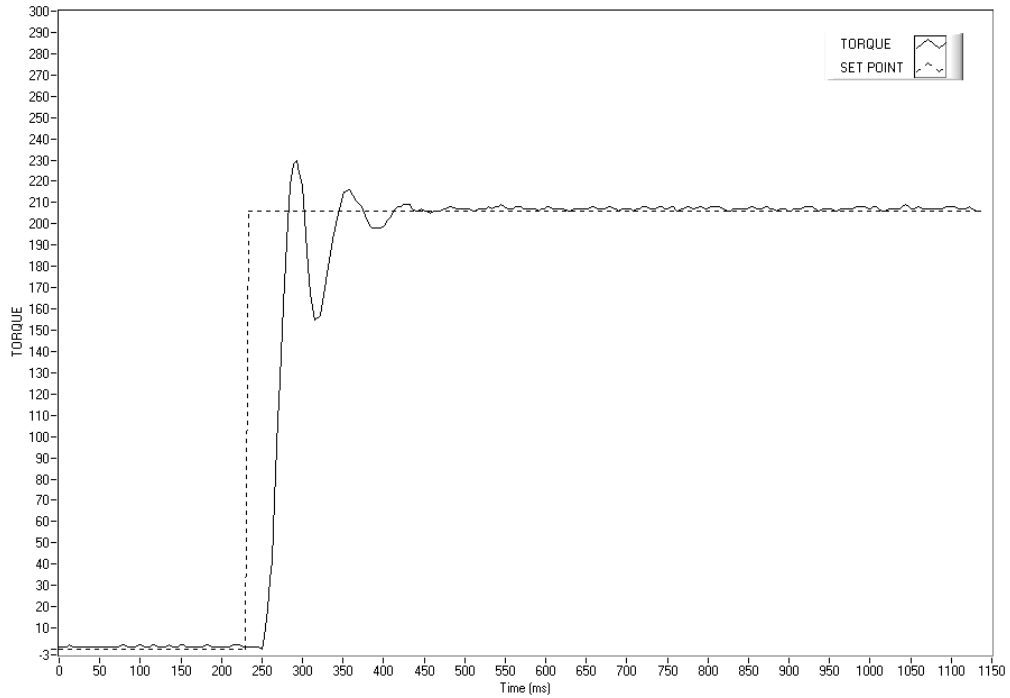

Figure 5–5 Initial I Setting for Torque Control

- c. If there is too much over shoot, increase the D term in 1% increments and repeat #8. For each incremental increase of the D term, reduce the P term by a proportional amount.

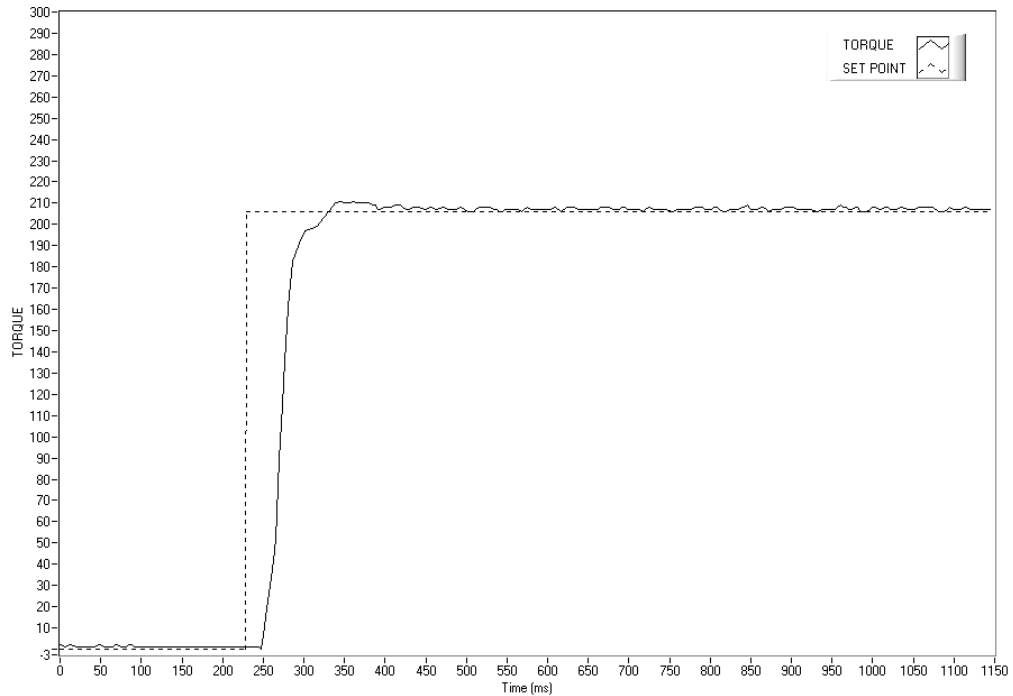

Figure 5–6 Initial D Setting for Torque Control

SETUP

5.5.3 SETTING THE PID FOR SPEED CONTROL

1. With the motor and brake OFF, set the desired Speed Set Point by pressing the SPEED SET button and using the UP ◀ and DOWN ▶ buttons and Decrease/Increase dial.
2. Set the P, I and D values to zero.
3. Turn the motor ON.
4. Turn the brake ON.
5. Slowly increase the P term until the speed read is about 25% of the desired load point.

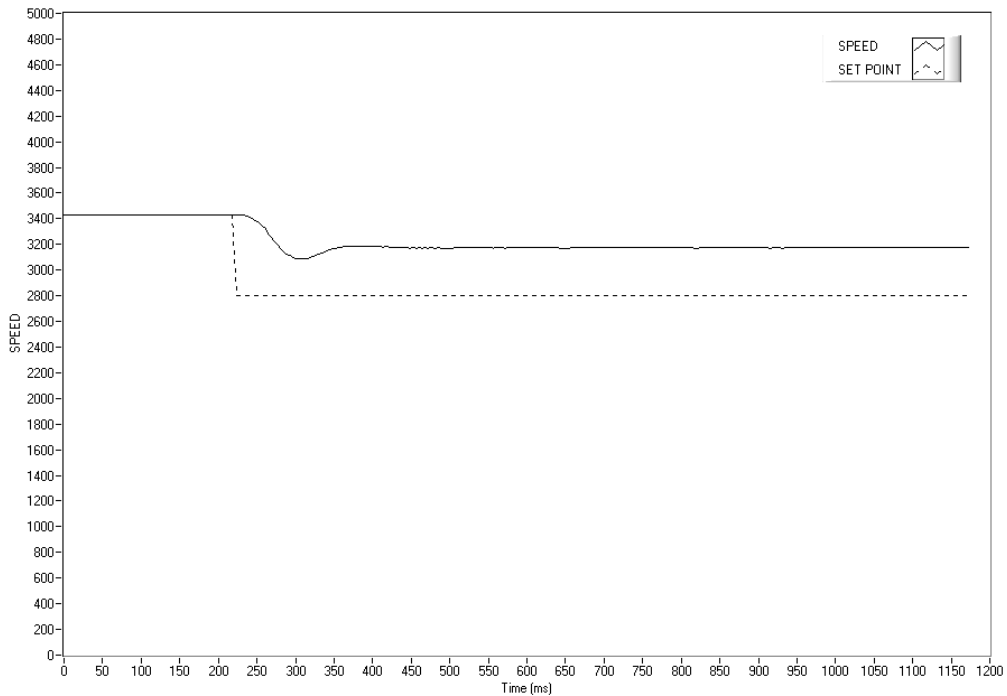

Figure 5–7 Initial P Setting for Speed Control at 25%

6. Turn the brake OFF.
7. Increase the I term to 10%.
8. Turn the brake ON and observe response, then turn the brake OFF. Desired Result is a fast response with some over shoot.
 - a. If the response was too slow, increase the I term in 1-5% increments and repeat #8.
 - b. If the response was too fast, decrease the I term in 1-5% increments and repeat #8.

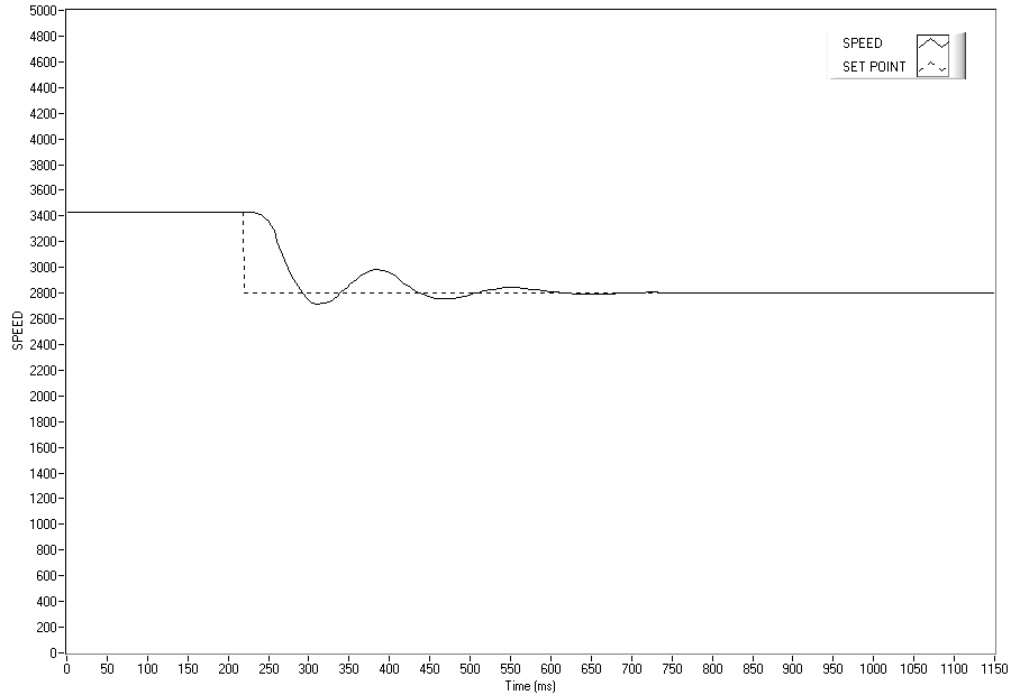

Figure 5–8 Initial I Setting for Speed Control

- c. If there is too much over shoot, increase the D term in 1% increments and repeat #8. For each incremental increase of the D term, reduce the P term by a proportional amount.

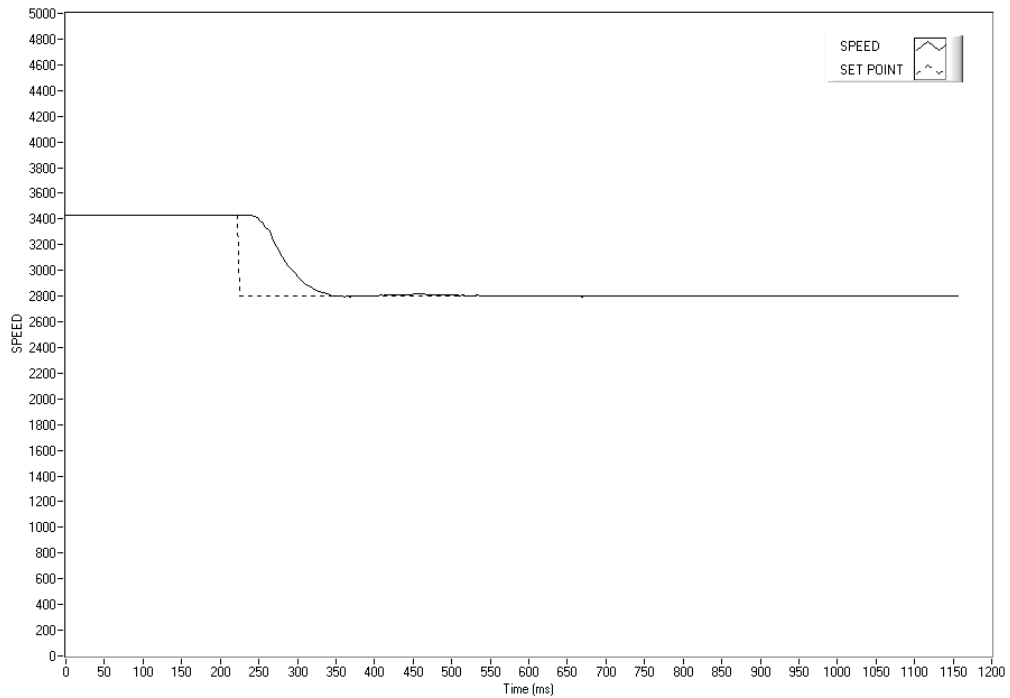

Figure 5–9 Initial D Setting for Speed Control

5.5.4 SETTING THE PID FOR RAMP DOWN

It is nearly impossible to select a PID value that optimizes the control loop over a wide range of speed. With Magtrol’s experience in motor test, their engineers have developed a dynamic PID algorithm. The PID values change with the Speed Set Point. In most cases, the PID values are high when the motor is lightly loaded and tend to decrease at higher loads.

Magtrol’s M-TEST Software provides a setup PID function in the setup for the ramp test. In the M-TEST Software, the dynamic scaling can be enabled or disabled and the span of the scaling can also be selected.

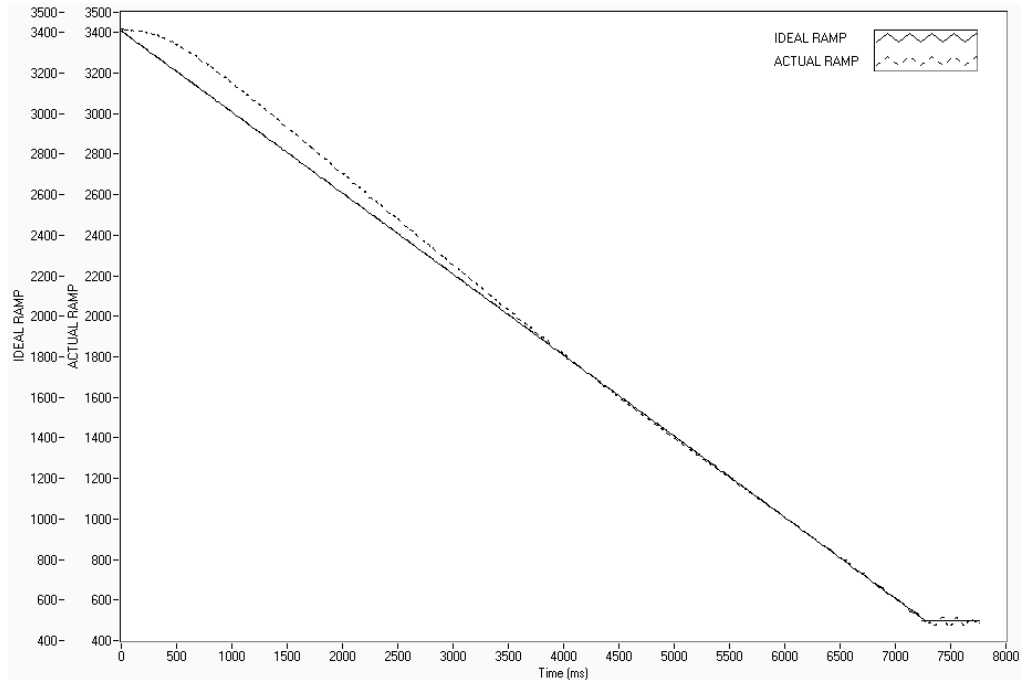

Figure 5–10 Ramp Down Low I

Ramp shows low value for I term. Note “bump” at beginning of ramp and good results toward end of ramp.

SETUP

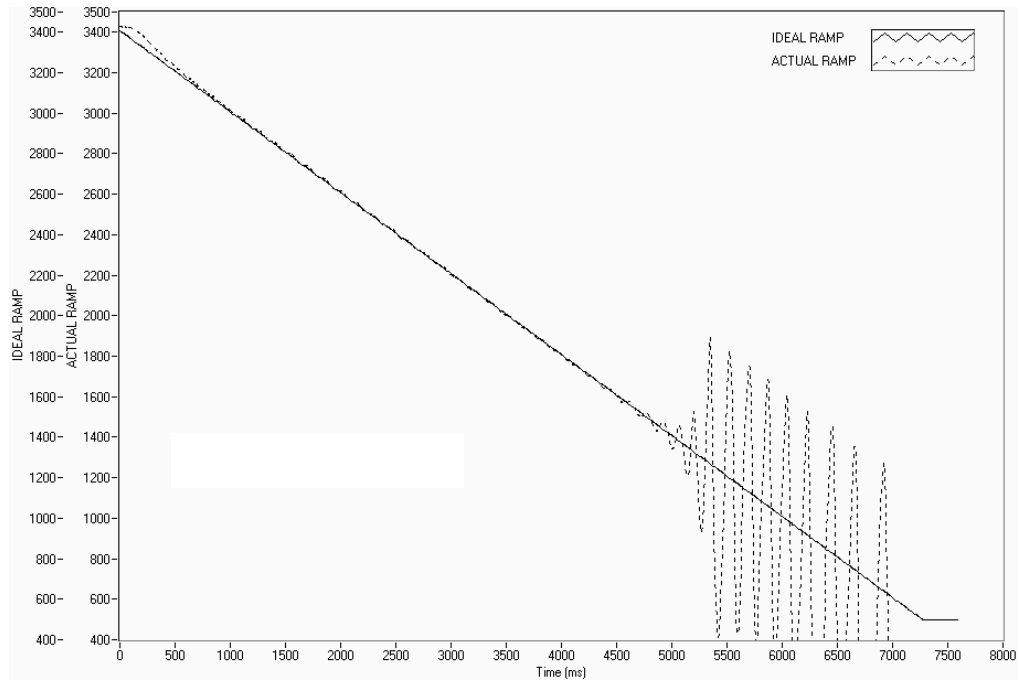

Figure 5-11 Ramp Down High I

Ramp shows higher value for I term. Note “bump” at beginning of ramp has been reduced but there are poor results toward end of ramp.

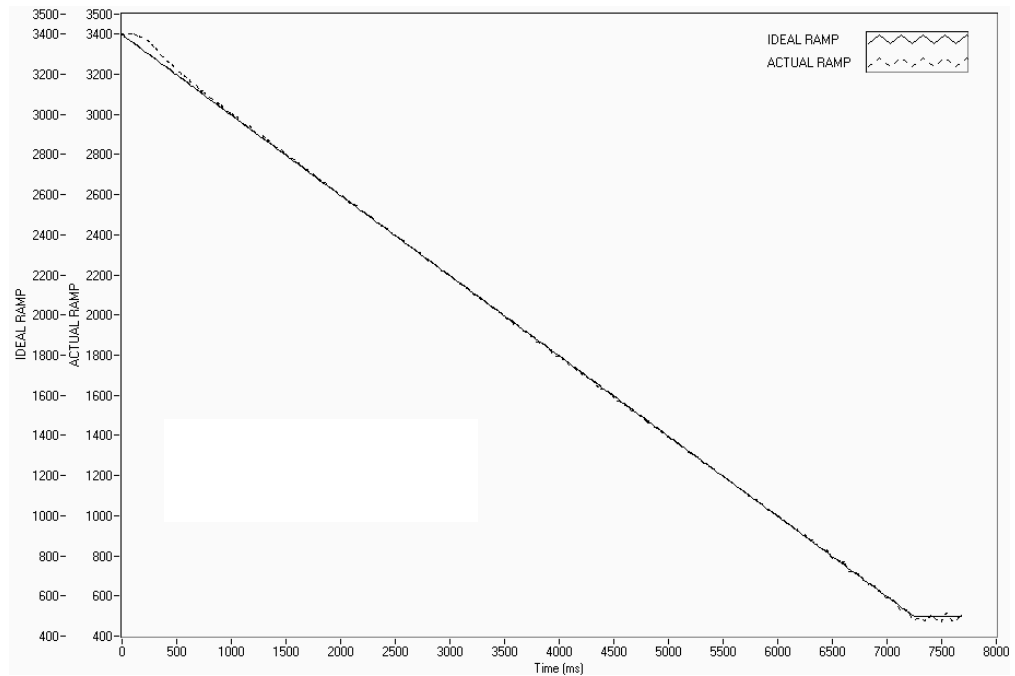

Figure 5-12 Ramp Down Dynamic I

Ramp shows Dynamic Scale effect. Note “bump” at beginning of ramp has been reduced and there are good results toward end of ramp. DIL was set to .01. At the end of the ramp, the I term is 1/100th of the starting value.

6. Alarm System

6.1 GENERAL INFORMATION

New to the DSP6001 is a built-in alarm system, designed to caution the user when problems occur. An automatic electrical and temperature alarm is programmed into the unit to protect against electrical overloads and overheating equipment when using a Magtrol DES 3XX Power Supply. There are also power, speed, torque, air flow, water flow and external input alarms internal to the unit, which only become active when enabled by the user. Instructions on how to set up and activate these alarms are included in this chapter.

6.1.1 ALARM RELAY

Internal to the DSP6001 is a relay that operates in conjunction with the alarms.

Relay Specifications:

- Contact Configuration: 1 FORM C
- Contact Rating: 1 amp, 24 VDC
- Manufacturer P/N: OMRON G5V-2-H1-DC24

The relay has normally open and normally closed contacts. Under normal conditions, the relay is energized as shown in *Figure 6-1*.

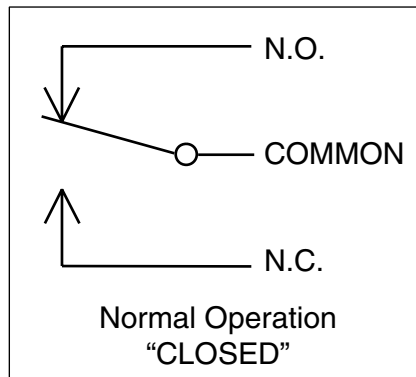

Figure 6-1 Normal Condition "Energized Relay"

In an alarm condition (or power failure), the relay is de-energized as shown in *Figure 6-2*.

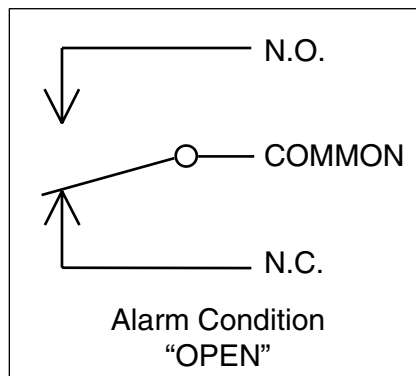

Figure 6-2 Alarm Condition "De-Energized Relay"

The relay contacts are made accessible on the Accessory Torque/Speed Output rear panel connector. See *Figure 2–6*.

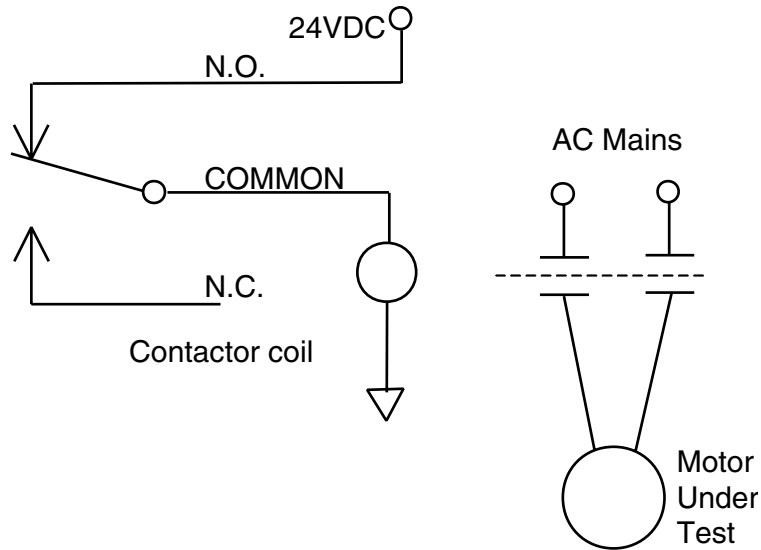

Figure 6–3 Typical Application

6.1.2 ALARM OPERATION

The DSP6001 gives the user the ability to enable or disable the alarms in the unit. The default is set in the OFF position. In order for the alarms to be operative the user must enable them.

6.1.2.1 How to Enable/Disable Alarms

1. Starting from main menu, press SHIFT.
2. Press DYNO SETUP button.
3. Select ALARMS.
4. Press SHIFT 3 times. The display should appear as follows:

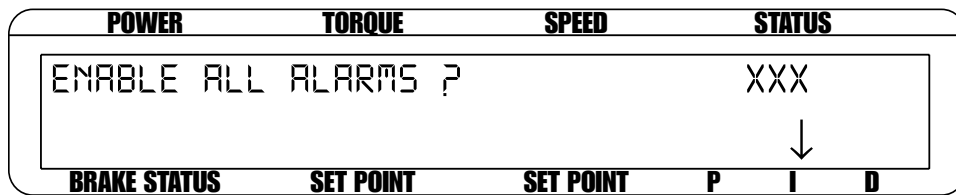

Figure 6–4 Alarm Enable/Disable Menu

5. Press COM SETUP button until you reach desired selection (YES or NO).
6. Press SHIFT 2 times to return to the main menu.



Note: Once the alarms are activated, they are only monitored for the channel that the control loop is closed on. For example, if the DSP6001 is controlling on TSC1, alarms for TSC2 are ignored.

6.1.3 ALARM PRIORITY

While in an alarm condition, a higher priority alarm will be acknowledged, while lower priority alarms are ignored. The priority order is as follows.

Priority	Alarm	Availability	
		Hysteresis Dynamometer	Eddy-Current/Powder Brake Dynamometer
1	Electrical Alarm	N/A	X
2	Temperature Alarm	N/A	X
3	External Alarm	X	X
4	Air Flow Alarm	X	N/A
5	Water Flow Alarm	N/A	X
6	Maximum Torque	X	X
7	Maximum Speed	X	X
8	Power	X	X

6.2 POWER ALARM

- Used to indicate an over power condition
- Default is set at 1 kW

6.2.1 INSTRUCTIONS FOR POWER ALARM SETUP

1. Starting from main menu, press SHIFT.
2. Press DYNO SETUP button.
3. Select MAXPOWER. The display should appear as follows:

POWER	TORQUE	SPEED	STATUS
TSC1/TSC2		MAX POWER	
TSC1		0.000 KILOWATTS	
BRAKE STATUS	SET POINT	SET POINT	P I D

Figure 6–5 Max Power Menu

4. Press MAX SPEED button and use UP ◀ and DOWN ▶ buttons and Decrease/Increase dial to set desired maximum power value for TSC1.
5. Press SHIFT.
6. Press POWER UNITS button, then MAX SPEED button and use UP ◀ and DOWN ▶ buttons and Decrease/Increase dial to set desired maximum power value for TSC2.
7. Press SHIFT 3 times to complete Power Alarm setup and return to the main menu.

6.2.2 POWER ALARM ACTION

When the power exceeds that of the maximum power setting, the message -OL- will appear and blink in the power section of the display accompanied by an audible beeping sound (as indicated in *Figure 6-6*).

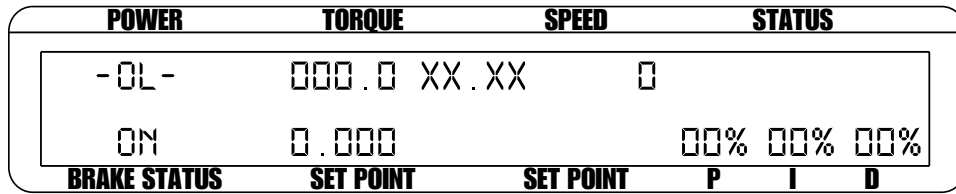

Figure 6-6 Power Alarm Display

Because torque and speed have separate settable limits, no other action will be taken. If condition persists the temperature sensors will open causing the temperature alarm to activate.

6.2.3 TO RESET POWER ALARM

This is a non-latching alarm. When the condition goes away, the alarm will automatically stop.

6.3 MAXIMUM SPEED ALARM

- Used to limit speed of system (motor, dynamometer, couplings, etc.)
- Default is set at 4000 rpm

6.3.1 INSTRUCTIONS FOR MAXIMUM SPEED ALARM SETUP

1. Starting from main menu, press SHIFT.
2. Press DYNO SETUP button.
3. Select ENCODERS. The display should appear as follows:

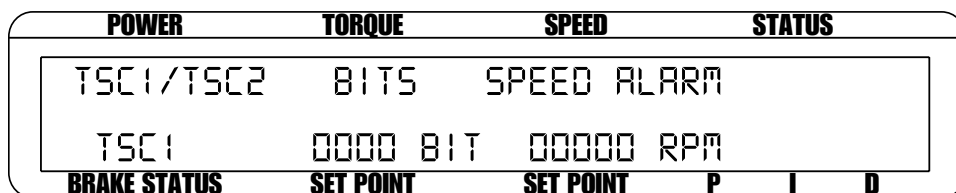

Figure 6-7 Speed Alarm Setup Menu

4. Press MAX SPEED button and use UP ◀ and DOWN ▶ buttons and Decrease/Increase dial to set desired maximum speed for TSC1.
5. Press SHIFT.
6. Press POWER UNITS button, then MAX SPEED button and use UP ◀ and DOWN ▶ buttons and Decrease/Increase dial to set desired maximum speed for TSC2.
7. Press SHIFT 3 times to complete Maximum Speed Alarm setup and return to the main menu.

6.3.2 MAXIMUM SPEED ALARM ACTION

- A. If speed is greater than the maximum speed setting but less than 120%, -OL- will flash on the display where the speed reading was (as indicated in *Figure 6–8*) and will be accompanied by an audible beeping sound.

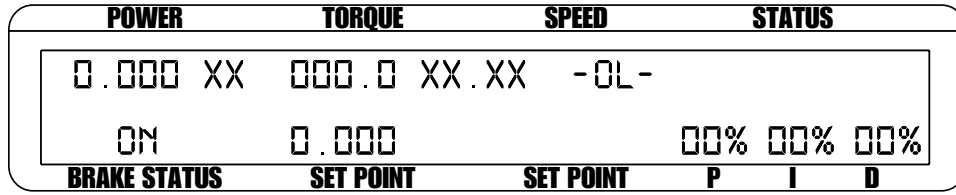

Figure 6–8 -OL- Speed Alarm Display

- B. If speed is greater than 120% of the maximum speed setting or in condition A for greater than 5 seconds, the display will flash “OVER SPEED ALARM TSCX” (as indicated in *Figure 6–9*) and will be accompanied by an audible beeping sound. The alarm relay will open, excitation current will hold at last value for 3 seconds then drop to zero.

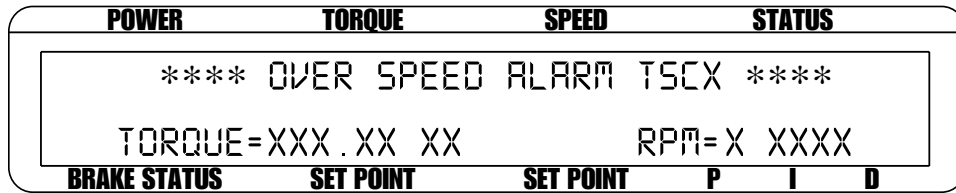

Figure 6–9 Over Speed Alarm Message Display

6.3.3 TO RESET MAXIMUM SPEED ALARM

Press any front panel button other than SHIFT. If the alarm condition is clear, the unit will return to normal operation. Although not recommended, another option would be to disable the alarm by following the alarm setup instructions in *Section 6.3.1 – Instructions for Maximum Speed Alarm Setup*.

6.4 MAXIMUM TORQUE ALARM

- Used to protect the system (motor, dynamometer, couplings, etc.) from over torque condition
- Default is set at 1 input unit

6.4.1 INSTRUCTIONS FOR MAXIMUM TORQUE ALARM SETUP

1. Starting from main menu, press SHIFT.
2. Press DYNO SETUP button.
3. Select DYNAMOMETER.
4. Press SHIFT. The display should appear as follows:

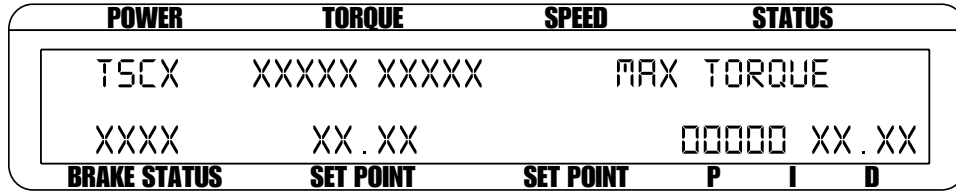

Figure 6–10 Torque Alarm Setup Menu

5. Press AUX SETUP button and use UP ◀ and DOWN ▶ buttons and Decrease/Increase dial to set desired maximum torque for TSC1.
6. Press SHIFT until Torque Alarm Setup Menu for TSC2 is reached.
7. Press AUX SETUP button and use UP ◀ and DOWN ▶ buttons and Decrease/Increase dial to set desired maximum torque for TSC2.
8. To complete Maximum Torque alarm setup, continue pressing SHIFT until main menu is reached.

6.4.2 MAXIMUM TORQUE ALARM ACTION

- A. If torque is greater than the maximum torque setting but less than 120%, -OL- will flash on the display where the torque reading was (as indicated in Figure 6–11), accompanied by an audible beeping sound.

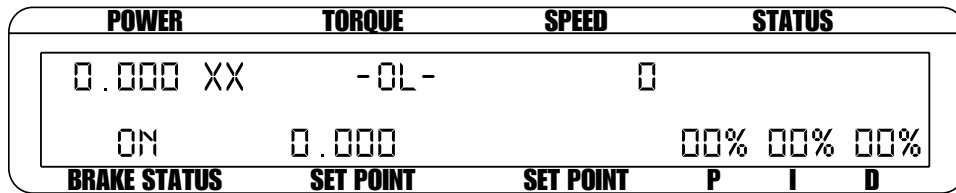

Figure 6–11 -OL- Torque Alarm Display

- B. If torque is greater than 120% of the maximum torque setting or in condition A for greater than 5 seconds, the display will flash “OVER TORQUE ALARM TSCX” (as indicated in Figure 6–12) and will be accompanied by an audible beeping sound. The alarm relay will open, excitation current will hold at last value for 3 seconds then drop to zero.

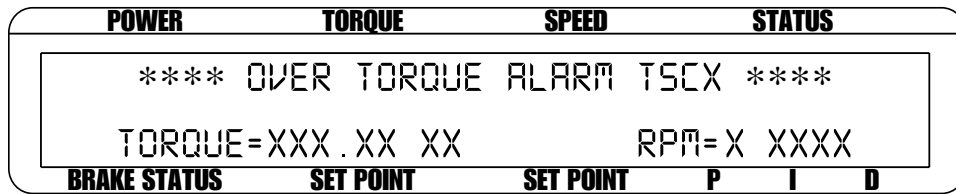

Figure 6–12 Over Torque Alarm Message Display

6.4.3 TO RESET MAXIMUM TORQUE ALARM

Press any front panel button other than SHIFT. If the alarm condition is clear, the unit will return to normal operation. Although not recommended, another option would be to disable the alarm by following the alarm setup instructions in Section 6.4.1 – Instructions for Maximum Torque Alarm Setup.

6.5 AIR FLOW ALARM

- Used to indicate a lack of air flow from a blower or air line
- Only for use with Hysteresis Dynamometers
- Monitored only when the brake is ON
- Default is set in “OFF” mode

6.5.1 INSTRUCTIONS FOR AIR FLOW ALARM SETUP

1. Starting from main menu, press SHIFT.
2. Press DYNO SETUP button.
3. Select ALARMS. The display should appear as follows:

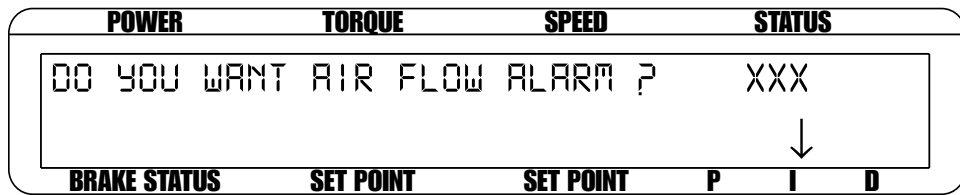

Figure 6–13 Air Flow Alarm Setup Display

4. Press COM SETUP button to select YES.
5. Press SHIFT 5 times to complete Air Flow Alarm setup and return to the main menu.

6.5.2 AIR FLOW ALARM ACTION

When there is a lack of air flow, the display will flash “LOW AIR FLOW” (as indicated in *Figure 6–14*) and will be accompanied by an audible beeping sound. The alarm relay will open and the excitation current will automatically drop to 10% of the last excitation current.

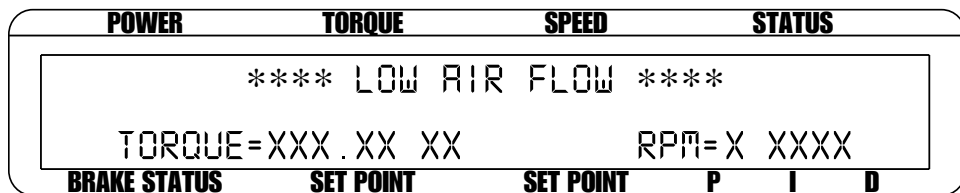

Figure 6–14 Air Flow Alarm Message Display

6.5.3 TO RESET AIR FLOW ALARM

Press any front panel button other than SHIFT. If the alarm condition is clear, the unit will return to normal operation. Although not recommended, another option would be to disable the alarm by following the alarm setup instructions in *Section 6.5.1 – Instructions for Air Flow Alarm Setup*.

6.6 WATER FLOW ALARM

- Used to indicate lack of water flow
- Only for use with Eddy-Current or Powder Brake Dynamometers
- Default is set in “OFF” mode
- Monitored only when the brake is “ON”

6.6.1 INSTRUCTIONS FOR WATER FLOW ALARM SETUP

1. Starting from main menu, press SHIFT.
2. Press DYNO SETUP button.
3. Select ALARMS.
4. Press SHIFT 2 times. The display should appear as follows:

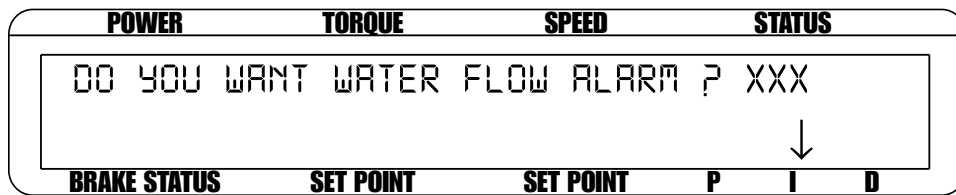

Figure 6-15 Water Flow Alarm Setup Display

5. Press COM SETUP button to select YES.
6. Press SHIFT 3 times to complete Water Flow Alarm setup and return to the main menu.

6.6.2 WATER FLOW ALARM ACTION

When there is a lack of water flow, the display will flash “LOW WATER FLOW” (as indicated in Figure 6-16) and will be accompanied by an audible beeping sound. The alarm relay will open and the excitation current will automatically drop to 10% of the last excitation current.

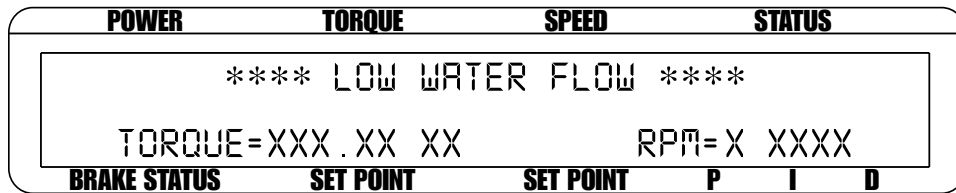

Figure 6-16 Water Flow Alarm Message Display

6.6.3 TO RESET WATER FLOW ALARM

Press any front panel button other than SHIFT. If the alarm condition is clear, the unit will return to normal operation. Although not recommended, another option would be to disable the alarm by following the alarm setup instructions in Section 6.6.1 – Instructions for Water Flow Alarm Setup.

6.7 EXTERNAL ALARM

- Used to shut down system based on additional user input
- Default is set in “OFF” mode

6.7.1 INSTRUCTIONS FOR EXTERNAL ALARM SETUP

1. Starting from main menu, press SHIFT.
2. Press DYN0 SETUP button.
3. Select ALARMS.
4. Press SHIFT. The display should read as follows:

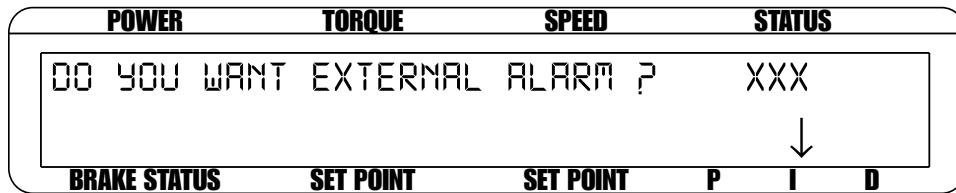

Figure 6-17 External Alarm Setup Display

5. Press COM SETUP button to select YES.
6. Press SHIFT 4 times to complete External Alarm setup and return to the main menu.

6.7.2 EXTERNAL ALARM ACTION

If the external input is at a high level, the display will flash “EXTERNAL ALARM” (as indicated in Figure 6-18) and will be accompanied by an audible beeping sound. The alarm relay will open and the excitation current will automatically drop to 10% of the last excitation current.

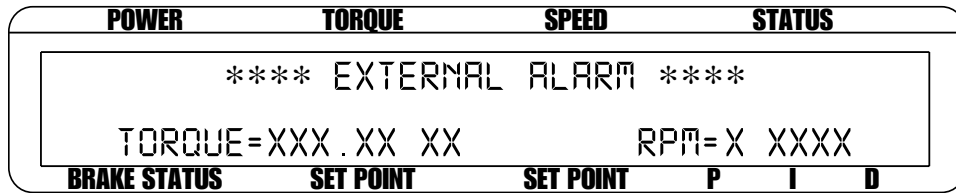

Figure 6-18 External Alarm Message Display

6.7.3 TO RESET EXTERNAL ALARM

Press any front panel button other than SHIFT. If the alarm condition is clear, the unit will return to normal operation. Although not recommended, another option would be to disable the alarm by following the alarm setup instructions in Section 6.7.1 – Instructions for External Alarm Setup.

6.8 TEMPERATURE ALARM

- To alert user when dynamometer gets too hot and thermal switch opens
- Only available for use with WB or PB dynamometers
- Default - always active

6.8.1 INSTRUCTIONS FOR TEMPERATURE ALARM SETUP

No setup needed.

6.8.2 TEMPERATURE ALARM ACTION

When the dynamometer in use becomes too hot, the display will flash “TEMPERATURE ALARM TSCX” (as indicated in *Figure 6–19*) and will be accompanied by an audible beeping sound. The alarm relay will open and the excitation current will immediately decrease to 10%. After approximately 3 seconds, the current will drop to 0.

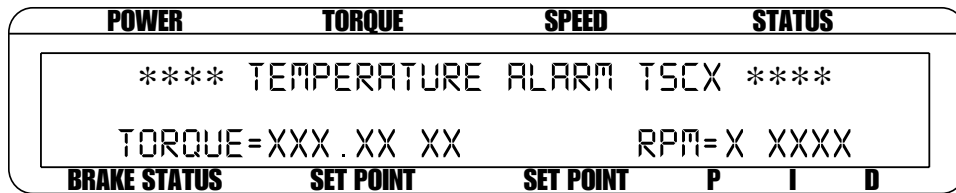

Figure 6–19 Temperature Alarm Message Display

6.8.3 To RESET TEMPERATURE ALARM

Press any front panel button other than SHIFT. The alarm condition must be cleared before the unit will return to normal operation.

SETUP • OPERATION

6.9 ELECTRICAL ALARM

- Used to protect the DES supply
- Monitors electrical input (mains) and circuitry of the DES
- Only available for use with WB or PB dynamometers
- Default - always active

6.9.1 INSTRUCTIONS FOR ELECTRICAL ALARM SETUP

No setup needed.

6.9.2 ELECTRICAL ALARM ACTION

When there is an electrical overload, the display will flash “ELECTRICAL ALARM TSCX” (as indicated in *Figure 6–20*) and will be accompanied by an audible beeping sound. The alarm relay will open and the excitation current will immediately decrease to zero.

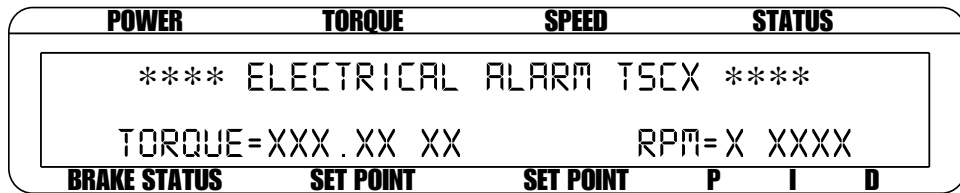

Figure 6–20 Electrical Alarm Message Display

6.9.3 TO RESET ELECTRICAL ALARM

Press any front panel button other than SHIFT. The alarm condition must be cleared before the unit will return to normal operation.

7. Manually Controlled Operation



Note: Using the DSP6001 without a computer will limit its testing capabilities.

7.1 HOW TO CHOOSE DESIRED CHANNEL WHEN USING TWO DYNAMOMETERS

To select the desired channel (TSC1 or TSC2):

1. Press SHIFT.
2. Press AUX SETUP button. The display should appear as follows:

POWER	TORQUE	SPEED	STATUS		
CL ON	TORQUE DAC		SPEED DAC		
TSCX	0.000 UNITS/V		0000	RPM/V	
BRAKE STATUS	SET POINT	SET POINT	P	I	D

Figure 7-1 Dynamometer Channel Menu

3. Press POWER UNITS button until the desired channel is reached.
4. Press SHIFT to return to main menu.



Note: The desired dynamometer channel must be chosen in order to continue with the following steps. All steps that are completed will be saved within that channel until the information is manually changed or the DSP6001 is reset. (To reset the DSP6001, refer to *Section 9.4 – Resetting the DSP6001.*)



Note: When using a dynamometer with a torque transducer or auxiliary instrument, the previous instructions will turn your TSC2 channel display “ON” allowing you to view information for both channels simultaneously.

7.2 HOW TO SET DESIRED POWER UNITS

To select the desired power units (W, kW or HP):

1. Press SHIFT.
2. Press POWER UNITS button. The display should appear as follows:

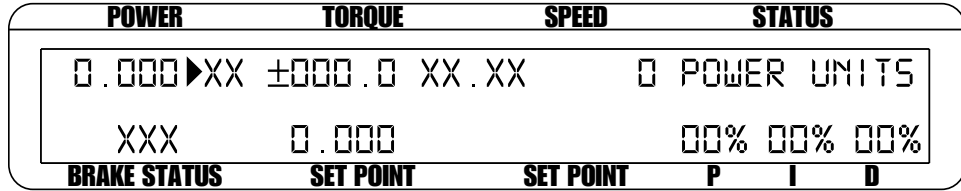

Figure 7-2 Power Units Menu

3. Use UP ◀ and DOWN ▶ buttons to select desired Power Units.
4. Press SHIFT to return to main menu.

7.3 HOW TO SET DESIRED TORQUE UNITS

To select the desired torque units (N.m, N.cm, N.mm, kg.cm., g.cm., lb.ft., lb.in., oz.ft., oz.in.):

1. Press SHIFT.
2. Press TORQUE UNITS button. The display should appear as follows:

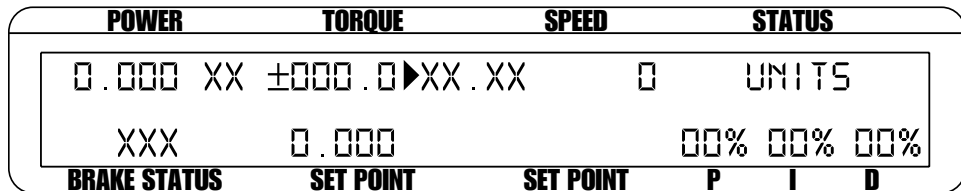

Figure 7-3 Torque Units Menu

3. Use UP ◀ and DOWN ▶ buttons to select desired Torque Units.
4. Press SHIFT to return to main menu.

7.4 HOW TO SET TORQUE CONTROL

1. Beginning with the brake in the OFF position, press the TORQUE SET button. The display should appear as follows:

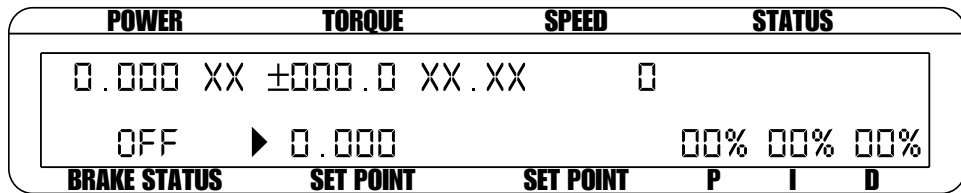

Figure 7-4 Torque Control Menu

2. Use UP ◀ and DOWN ▶ buttons and the Decrease/Increase dial to adjust the setpoint to zero.

OPERATION



Note: PID values should be set at this time. See *Section 5.5 – Setting the Correct PID's for Your Motor.*

3. Use the BRAKE ON/OFF button to turn the brake ON.
4. Start the motor under test.
5. Press the TORQUE SET button and adjust the set point to the desired load.
6. Check the torque display to make sure that the dynamometer loads the motor under test to that torque load.

Desired Results

The dynamometer should load the motor under test to the load point quickly with little or no overshoot when the BRAKE function cycles ON or OFF.



Note: If the response is too slow or oscillatory, adjust the values for P, I and D. (For more detailed instruction, refer to *Chapter 5– PID Settings.*)



CAUTION: DO NOT EXCEED THE CAPABILITIES OF THE DYNAMOMETER OR THE POWER SOURCE IN USE. MOTORS DRAW VERY LARGE CURRENTS WHEN HELD AT LOCKED ROTOR AND OVERHEATING MAY RESULT. WHEN USING TORQUE CONTROL, INDUCTION MOTORS CANNOT BE TESTED BEYOND BREAKDOWN, EXCEPT AT LOCKED ROTOR. REFER TO *SECTION 7.5 – HOW TO SET SPEED CONTROL.*

7.5 HOW TO SET SPEED CONTROL



Note: When using speed control, motors between 0 and 100 rpm cannot be tested unless the dynamometer is equipped with an optional, high resolution speed encoder.

1. Beginning with the brake in the OFF position, press SHIFT.
2. Press MAX SPEED button. The display should appear as follows:

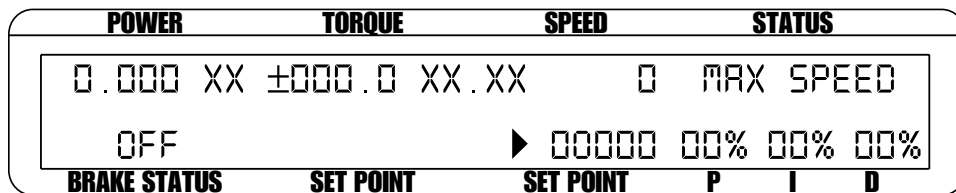

Figure 7–5 Max Speed Menu

3. Use UP ◀ and DOWN ▶ buttons and the Decrease/Increase dial to set a value equal to or slightly greater than the free-run speed of the motor under test.

4. Press the SHIFT button to exit the MAX SPEED function.
5. Press the SPEED SET button.
6. Use UP ◀ and DOWN ▶ buttons and the Decrease/Increase dial to set a speed equal to the max. speed.



Note: PID values should be set at this time. See *Section 5.5 – Setting the Correct PID's for Your Motor.*

7. Use the Brake ON/OFF button to turn the brake ON.
8. Start the motor under test.
9. Press the SPEED SET button and adjust the set point to the desired speed.

Desired Results

The dynamometer should load the motor under test to the desired speed quickly with little or no overshoot when the BRAKE button is cycled ON or OFF.



Note: If the response is too slow or oscillatory, adjust the values for P, I and D. For more detailed instruction, refer to *Chapter 5 – PID Settings.*

7.6 HOW TO SET OPEN LOOP CONTROL

1. Beginning with the brake in the OFF position, press and hold the TORQUE SET button until a second beep is heard. The open loop control menu should appear. See *Figure 5–2 Open Loop Control Menu.*
2. Use UP ◀ and DOWN ▶ buttons and the Decrease/Increase dial to set a value of current equal to the percent of full scale output.
3. If needed, POWER UNITS and DISPLAYED UNITS can be changed while in OPEN LOOP mode. (For further instruction, refer to *Section 7.2 – How to Set Desired Power Units.*)
4. Use the BRAKE ON/OFF button to turn the brake ON. (Note: When the brake is on, the only thing that can be adjusted is the set point. There are no other active settings at this time.)
5. To exit the Open Loop Control mode and return to the main menu, turn the brake OFF and press and hold the TORQUE SET button until a second beep is heard.

Desired Results

The dynamometer should load the motor under test. Because the mode is open loop, the controller will not stabilize on speed or torque, but will apply a constant current to the dynamometer brake. The actual loading will change as the brake heats up or as other external factors change. The PID's have no effect in this mode.

8. Computer Controlled Operation

The DSP6001 can be used with a computer to control a dynamometer and to transmit data from the motor testing device directly to the computer. Using the DSP6001 with a computer enables the unit to perform at its full capacity.

8.1 ABOUT THE GPIB INTERFACE

(General Purpose Interface Bus)

Magtrol instruments use the GPIB (IEEE-488 Standard) for computer-to-instrument interfacing because:

- The GPIB parallel interface is faster than serial interfaces.
- The GPIB enables testers to access up to 15 instruments on one port. Because typical motor testing requires that at least five separate parameters be synchronized, a system of easy, fast access to more than one instrument is essential.
- The GPIB has rigid data formatting and hardware standards. These standards help to ensure that all functions will work properly when the hardware and software are installed.



Note: The GPIB interface is not standard on most computers. An interface card and driver software must be installed. An IEEE-488 cable must also be installed between the computer and the DSP6001. Magtrol recommends National Instruments Corporation hardware and software.

8.1.1 INSTALLING THE GPIB (IEEE-488) CONNECTOR CABLE



CAUTION: MAKE SURE BOTH THE COMPUTER AND DSP6001 ARE TURNED OFF BEFORE INSTALLING THE GPIB CONNECTOR CABLE.

1. Connect one end of a high-quality, double-shielded cable to the DSP6001 GPIB connector.
2. Connect the other end to the GPIB interface in your PC

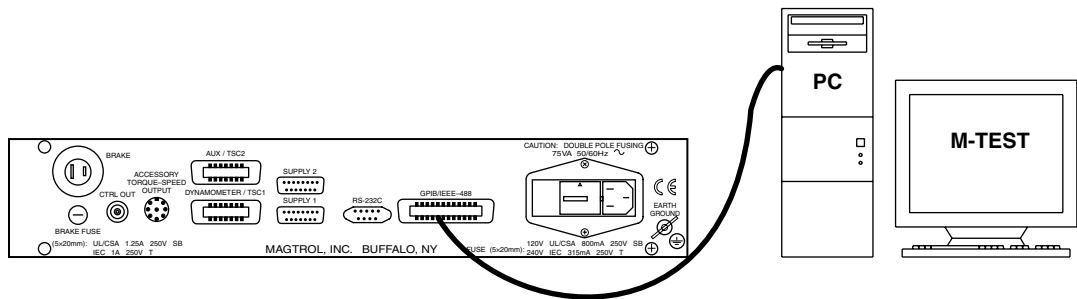

Figure 8-1 GPIB Installation

8.1.2 CHANGING THE GPIB PRIMARY ADDRESS

Each instrument serviced by the GPIB has its own Primary Address code, which enables the computer to obtain readings from the instrument. The factory default of the setting on the DSP6001 is 09.

Some PC interfaces can access from one to fifteen 4-bit primary addresses. Other interfaces can access as many as thirty-one 5-bit primary addresses. The DSP6001 uses the 4-bit format. For setup, follow the steps below.

1. Press the SHIFT button and release.
2. Press the COM SETUP button. The display should appear as follows:

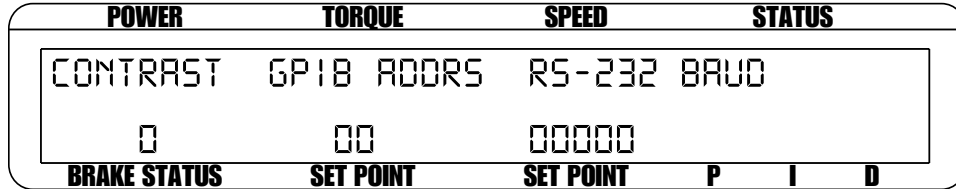

Figure 8–2 Com Setup Menu Display

3. Press the button below the GPIB display until the desired primary address is reached (range 0-15).
4. Press SHIFT to exit and return to main menu.

8.2 ABOUT THE RS-232 INTERFACE

The DSP6001 is equipped with an RS-232 (serial) interface that communicates with the host computer through a DB-9 interface connector. The connector pin-out consists of 2-TX, 3-RX and 5-GND.

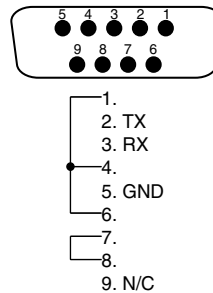

Figure 8–3 RS-232 Interface

8.2.1 CONNECTION

The RS-232 connection includes null modem wiring internal to the unit. To install, use a straight through pin-to-pin connector cable, which can be purchased from your local electronics store.

OPERATION

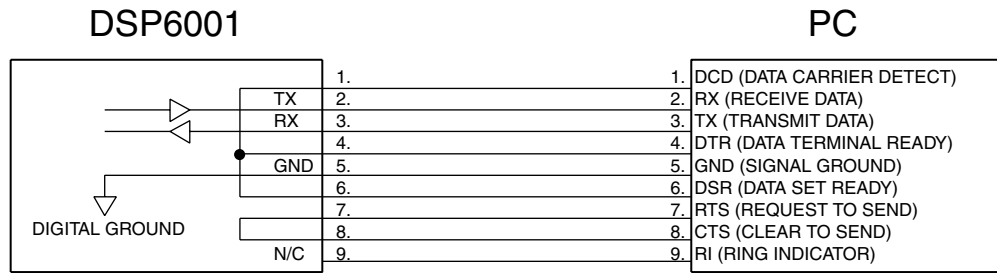

Figure 8-4 Straight Through Pin-to-Pin Cable Connection

8.2.2 COMMUNICATION PARAMETERS

- No parity
- 8 data bits
- 1 stop bit

8.2.3 BAUD RATE

There are several different baud rates to choose from including 300, 600, 1200, 2400, 4800, 9600 and 19200. To set up the desired baud rate, follow the instructions below.

1. Press SHIFT and release.
2. Press the COM SETUP button. The display will appear as shown in *Figure 8-2 Com Setup Menu Display*.
3. Press the button under the RS-232 BAUD display until the desired baud rate is reached.
4. Press SHIFT to return to main menu.

8.3 CHECKING THE DSP6001-TO-PC CONNECTION



Note: Make sure that the DSP6001 and its host computer are communicating before acquiring data.

1. Make sure the primary GPIB address is set correctly for the DSP6001.
2. Set the input variable to 15 characters (13 variable characters and the two required data termination characters CR and LF. See *Section 8.5 – Programming*.)
3. Issue output data command “OD” and read 15 characters according to the instructions for your GPIB interface or serial.

Desired Results

- Torque/speed data will be returned.
- The error message I/O ERROR does not appear on the display panel.



Note: If the desired results did not occur, please see *Chapter 10 – Troubleshooting*.

OPERATION

8.4 DATA FORMAT

Speed-torque data is a fixed-length string in ASCII format with a floating point decimal. Use the following string format:

$$S\text{d}\text{d}\text{d}\text{d}\text{d}\text{T}\text{d}\text{d}\text{d}\text{d}\text{.R}(\text{cr})(\text{lf})$$

Or

$$S\text{d}\text{d}\text{d}\text{d}\text{d}\text{T}\text{d}\text{d}\text{d}\text{d}\text{.L}(\text{cr})(\text{lf})$$

Where...

S = Speed in rpm. (No leading zeroes are used.)

d = Decimal digit 0 through 9.

T = Torque in units selected during setup. (The torque value always contains a decimal point.)

L = Counterclockwise dynamometer shaft rotation (left).

R = Clockwise dynamometer shaft rotation (right).

. = Decimal point. (The decimal point location depends on the specific dynamometer and torque range in use.)



Note: When an “A” is in the R/L position (e.g. Sd d d d d T d d d d .A(cr)(lf)), it is an indication that the unit is in an alarm condition.



Note: The (cr) and (lf) characters will not display.

EXAMPLE

If a motor is running at 1725 rpm clockwise, with the dynamometer loading the motor to 22.6 oz.in., the DSP6001 will return:

$$S\ 1725T22.60R$$

By manipulating the string, the speed-torque and shaft direction (if required) can be extracted. Then separate numerical variables can be assigned to them for data processing.

8.5 PROGRAMMING



Note: Check the manual provided with your software for full instructions.

8.5.1 DATA TERMINATION CHARACTERS

Use the following information to answer the formatting questions asked when installing your GPIB software. All GPIB data acquisition systems require the use of data termination characters. The DSP6001 uses the GPIB standard termination characters Carriage Return (CR) and Line Feed (LF). Provide them in that order.

8.5.1.2 Codes for CR - LF

	BASIC	HEX	DEC
CR =	CHR\$(13)	0D	13
LF =	CHR\$(10)	0A	10

8.5.2 TIMEOUT

Set the timeout for at least one second if asked to set a communication fault delay timeout.



Note: If the communication fault delay timeout is too short, or if the computer resets the interface too quickly, the host instrument may stop responding.

8.6 DSP6001 COMMAND SET

When entering a command code:

1. Type all characters in uppercase ASCII format.
2. End all commands with a CR-LF (hex 0D-0A).
3. Do not string multiple commands together in one line.

The character # represents a floating-point numerical value following the command. Leading zeroes are not required.



Note: If a command is not recognized, the I/O ERROR message will appear in the Status Display accompanied by a beep.

8.6.1 ALARM COMMANDS

Command Code	Function	Explanation
ALA#	Enables or disables air flow alarm.	Values for # are: 0 = disable 1 = enable
ALE#	Enables or disables external alarm.	Values for # are: 0 = disable 1 = enable
ALL#	Enables or disables all alarms.	Values for # are: 0 = disable 1 = enable
ALP#	Sets power alarm.	Sets maximum power in kilowatts. Range is 0 to 99,999. Setting is applied to current channel.
ALS#	Sets speed alarm point.	Sets maximum speed in rpm. Range is 0 to 99,999. Setting is applied to current channel.
ALT#	Sets torque alarm point.	Sets maximum torque in input units. Range is 0 to 10,000. Setting is applied to current channel.
ALW#	Enables or disables water flow alarm.	Values for # are: 0 = disable 1 = enable

8.6.2 COMMUNICATION COMMANDS

Command Code	Function	Explanation
*IDN?	Returns Magtrol Identification and software revision.	
OA	Prompts to return to auxiliary input data string.	Output Auxiliary prompt to return the value at the AUX INPUT x AUX SCALING factor with this format: Axxxxxcrlf
OD	Prompts to return speed-torque-direction data string.	Output Data prompt to return data string with this format: SxxxxTxxxxRcrlf or SxxxxTxxxxLcrlf or SxxxxTxxxxAcrlf R or L is the shaft direction indicator, as viewed looking at the dynamometer shaft where: R = right; clockwise (CW) L = left; counterclockwise (CCW) A = alarm condition The speed will equal the displayed value and the torque will be in the same units as displayed on the front panel.
OR	Prompts to return direction bit of TM2XX.	“Output Rotation” prompt to return the value at the direction input with this format: 0crlf = clockwise 1crlf = counterclockwise

8.6.3

RAMP COMMANDS

Command Code	Function	Explanation
DILXX.XX	Sets dynamic scale coefficient.	When using dynamic scaling, XX.XX is multiplied by the I term to give the end I value.
DPLXX.XX	Sets dynamic scale coefficient.	When using dynamic scaling, XX.XX is multiplied by the P term to give the end P value.
DS#	Enable or disables dynamic scaling.	Values for # are: 0 = disable 1 = enable
PD#	Sets ramp down rate to #RPM per second.	Specify speed range (F#) AND a stop speed (S#) before using this command. This command programs a decreasing shaft speed at a rate of #rpm per second. Once initiated, the Controller will load to locked rotor unless instructed to do otherwise.
PR	<ul style="list-style-type: none"> • Resets ramp up or down. • Sets speed to maximum speed. • Turns brake off. 	This command resets the ramp function, halting the ramp's progress, and returns the motor to free run.
PU#	Sets ramp up rate to #RPM per second.	Specify speed range (F#) AND a start speed (S#) before using this command. This command increases the shaft speed at a rate of #rpm per second.
S#	Sets start or stop speed for ramp to #RPM.	When this command is used with the PD (Program Down) command, the Controller will ramp down to this speed and halt. When this command is used with the PU (Program Up) command, the Controller will load immediately to this speed and ramp up to free-run.

8.6.4 SETUP COMMANDS

Command Code	Function	Explanation
AF1#	Sets the analog filter for TSC1.	Values for # are: 0 = OFF 1 = 10 Hz 2 = 25 Hz 3 = 50 Hz 4 = 3 Hz
AF2#	Sets the analog filter for TSC2.	Values for # are: 0 = OFF 1 = 10 Hz 2 = 25 Hz 3 = 50 Hz 4 = 3 Hz
BT#	Sets the brake type for TSC1.	Values for # are: 0 = HD 1 = WB 2 = PB
DIN1#	Selects instrument type connected to TSC1.	Values for # are: 0 = HD 1 = WB 2 = PB 3 = BRAKE
DIN2#	Selects instrument type connected to TSC2.	Values for # are: 0 = AUX 1 = WB 2 = PB 3 = TM2XX
M#	Enables or disables front panel controls.	Values for # are: 0 = disable 1 = enable NOTE: The brake ON/OFF switch on the front panel still functions.
NS#	Sets nominal speed for WB Dynamometer.	Range is 0 to 99,999. Setting is applied to current channel.
R	Resets as follows: • Manual control ON. • Brake OFF.	Use this command to cancel any previous commands. Note: These settings are the power-on default settings.
SFC#	Enables or disables cross loop function.	Values for # are: 0 = disable 1 = enable
SFT#	Enables or disables tandem function.	Values for # are: 0 = disable 1 = enable
TSC1	Selects TSC1 to be the channel that the control loop closes on.	The TSC1 or TSC2 command should be the first command sent during testing. All commands thereafter will be applied to that channel.
TSC2	Selects TSC2 to be the channel that the control loop closes on.	
TSF1#	Sets scale factor for TSC1.	Range is 0 to 99,999.
TSF2#	Sets scale factor for TSC2.	Range is 0 to 99,999.

Command Code	Function	Explanation
UA#	Sets auxiliary input scaling to #.	This command sets the scaling factor for the auxiliary input to # units/volt. The range is 0.0 to 10000.0. Programmed value # is not saved at power down.
UE#	Sets encoder pulse count to #.	This command selects the pulse count option for speed transducing. Values for # are: 0 = 60-bit 1 = 600-bit 2 = 6000-bit 3 = 20-bit 4 = 30-bit Programmed value # is not saved at power down.
UI#	Sets dynamometer torque units to #.	NOTE: For Hp and watts calculations to be correct, the correct dynamometer torque units must be specified. Values for # are: 0 = oz.in. 1 = oz.ft. 2 = lb.in. 3 = lb.ft. 4 = g.cm. 5 = kg.cm. 6 = N.mm. 7 = N.cm. 8 = N.m. Torque units default to 0 (oz.in.) if out of range. Programmed value # is not saved at power down.
UR#	Sets readout torque units to #.	This command sets the torque unit conversion for the torque readout. Values for # are 0 = oz.in. 1 = oz.ft. 2 = lb.in. 3 = lb.ft. 4 = g.cm. 5 = kg.cm. 6 = N.mm. 7 = N.cm. 8 = N.m. Torque units default to 0 (oz.in.) if out of range. Programmed value # is not saved at power down.

OPERATION

8.6.5 SPEED COMMANDS

Command Code	Function	Explanation
F#	Sets maximum speed to # rpm.	Sets a speed range for the Controller. Must be specified before using the speed or ramp mode.
G#	Sets maximum speed excited of PB.	Range is 0 to 10,000.
N	<ul style="list-style-type: none"> Resets speed point to maximum speed. Sets speed mode OFF. Sets brake OFF. 	Use this command, sent alone, to reset any previous speed-stabilized setting to the maximum speed range.
N#	<ul style="list-style-type: none"> Sets speed point to #. Sets brake ON. 	Use this command to load the motor under test to a specific speed value #. Issue a speed range command (F#) first for best dynamic response. The Controller is functioning with the dynamometer as a closed loop system. Adjust the speed PID values to tune the response.
ND#	Sets speed derivative to #.	Derivative value # can be any number from 0 to 99.
NDS#	Used as a multiplier for the D coefficient in the PID equation.	Values for # are A, B, C, D, E, F, G, H or I. (See <i>Appendix F: Additional Scale Factor Table.</i>)
NI#	Sets speed integral to #.	Integral value # can be any number from 0 to 99.
NIS#	Used as a multiplier for the I coefficient in the PID equation.	Values for # are A, B, C, D, E, F, G, H or I. (See <i>Appendix F: Additional Scale Factor Table.</i>)
NP#	Sets speed proportional to # gain.	Proportional gain value # can be any number from 0 to 99.
NPS#	Used as a multiplier for the P coefficient in the PID equation.	Values for # are A, B, C, D, E, F, G, H or I. (See <i>Appendix F: Additional Scale Factor Table.</i>)

8.6.6 TORQUE COMMANDS

Command Code	Function	Explanation
Q	<ul style="list-style-type: none"> Resets torque to 0.0. Turns torque mode OFF. Turns brake OFF. 	This command resets any previous torque-stabilized command, and returns the motor to free run.
Q#	<ul style="list-style-type: none"> Sets torque point to #. Turns brake ON. 	This is a closed loop command with its own set of PID parameters. The units defined will be the same as those displayed by the Controller.
QD#	Sets torque derivative to #.	Derivative value # can be any number from 0 to 99.
QDS#	Used as a multiplier for the D coefficient in the PID equation.	Values for # are A, B, C, D, E, F, G, H or I. (See <i>Appendix F: Additional Scale Factor Table.</i>)
QI#	Sets torque integral to #.	Integral value # can be any number from 0 to 99.
QIS#	Used as a multiplier for the I coefficient in the PID equation.	Values for # are A, B, C, D, E, F, G, H or I. (See <i>Appendix F: Additional Scale Factor Table.</i>)
QP#	Sets torque proportional to # gain.	Proportional gain value # can be any number from 0 to 99.
QPS#	Used as a multiplier for the P coefficient in the PID equation.	Values for # are A, B, C, D, E, F, G, H or I. (See <i>Appendix F: Additional Scale Factor Table.</i>)

8.6.7 MISCELLANEOUS COMMAND

Command Code	Function	Explanation
DIR#	Selects/Deselects the quadrature input circuitry. User has access to up/down counter via OH1 command. The displayed rpm is sent to the GPIB/RS-232 and applied to the PID Loop. NOTE: Only applies to DSP6001 Revision 7.5 and later versions.	Values for # are: 0 = for single frequency 1 = for quadrature input
I#	Sets current output to #.	The power supply outputs a fixed value of current. Use any value # between 0 and 99.99%. (99.99% = 1 Amp).
IOXX.XX	Applies an offset to the output DAC on channel 1 only. Used to clamp motor speed prior to testing. NOTE: Only applies to DSP6001 Revision 7.6 and later versions.	Values for # range from 0 to 99.99.
OH1	Returns quadrature counter information.	Two 24-bit hex values are returned. The first value is the up/down count. The second value is an unused value.
SAVE	Saves present configuration of unit to non-volatile memory.	
X	Prompts to return % current output.	This command returns the % current value in the format "I##.##". The value will be between 0 (no loading) and 99.99 (full loading).



Note: For further reference, see *Appendix F – Remote Configuration Flow Charts*.

9. Calibration

9.1 CLOSED-BOX CALIBRATION

The DSP6001 features closed-box calibration. The advantage of closed-box calibration is that the user does not have to disassemble the case or make mechanical adjustments.

9.2 CALIBRATION SCHEDULE

Calibrate the DSP6001:

- After any repairs are performed.
- At least once a year; more frequently to ensure required accuracy.

9.3 BASIC CALIBRATION PROCESS

The basic calibration process consists of four procedures which must be performed in the following order:

1. Initial Calibration Procedure
2. TSC1 Offset and Gain
3. TSC2 Offset and Gain
4. DAC Output Offset and Gain
5. Speed Check
6. Decimal Point Check

Items needed for calibrating the DSP6001:

- External voltage reference of 0 to 5 volts DC
- Digital multimeter (DMM)

Both instruments should have a VDC accuracy of 0.05% or better.

9.3.1 INITIAL CALIBRATION PROCEDURE

1. Allow the DSP6001 to stabilize in an environment with:
 - An ambient temperature of 18°C to 25°C.
 - Relative humidity less than 80%.
2. Turn on the DSP6001.
3. Allow the DSP6001 to warm up for at least 30 minutes.
4. Enable the calibration mode as follows:
 - Turn instrument power OFF.
 - Press in and hold the UP ◀ and DOWN ▶ buttons simultaneously.
 - Turn instrument power ON.
 - Continue pressing the UP ◀ and DOWN ▶ buttons until the display shows the software revision date then release.

The front panel displays the actual correction factors above the ZERO and GAIN readouts (see *Figure 9-1 Calibration Display Analog Inputs*).

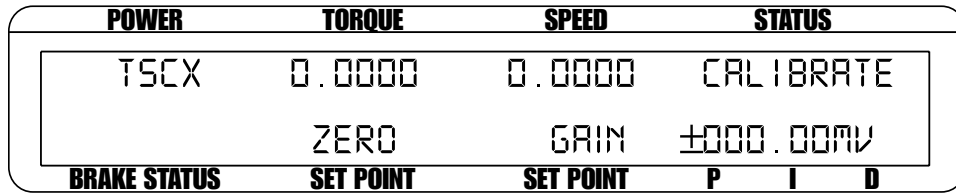

Figure 9-1 Calibration Display Analog Inputs



Note: To exit CALIBRATE mode without making any changes, press the SHIFT button 8 times.

9.3.2 TSC1 OFFSET AND GAIN

1. Connect the external voltage reference common to Pin 13 of the TSC1 input connector.
2. Connect the external voltage reference high to Pin 14 of the TSC1 input connector.

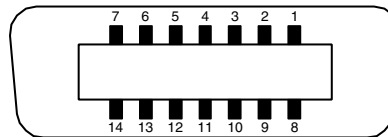

- | | |
|----------------|-------------------|
| 1. FLOW/CLUTCH | 8. +5.0 VDC COM |
| 2. TACH. B | 9. D.P. A |
| 3. +24 VDC | 10. TACH. A |
| 4. +24 VDC COM | 11. INDEX |
| 5. -24 VDC COM | 12. D.P. B |
| 6. -24 VDC | 13. TORQUE COMMON |
| 7. +5.0 VDC | 14. TORQUE SIGNAL |

Figure 9-2 TSC1 Input Connector

3. Apply +0.000 VDC.
4. Press the ZERO button.
5. Adjust the ZERO by turning the Decrease/Increase Dial until the displayed voltage equals the reference voltage (within 00.10 mV).



Note: The magnitude of change per revolution can be increased by pressing the UP ◀ button or decreased by pressing the DOWN ▶ button.

6. Apply 5.0 VDC.
7. Press the GAIN button.
8. Adjust the Decrease/Increase Dial until the displayed voltage equals the reference voltage within 00.10 mV.
9. Press SHIFT to proceed to Section 9.3.3 – TSC2 Offset and Gain.

MAINTENANCE

9.3.3 TSC2 OFFSET AND GAIN

1. Connect the external voltage reference common to Pin 13 of the TSC2 input connector.
2. Connect the external voltage reference high to Pin 14 of the TSC2 input connector.

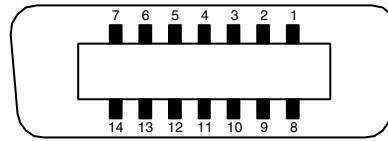

- | | |
|----------------|-------------------|
| 1. SPARE | 8. +5.0 VDC COM |
| 2. N/C | 9. ROT_SENS |
| 3. +24 VDC | 10. TACH. C |
| 4. +24 VDC COM | 11. N/C |
| 5. -24 VDC COM | 12. BITE |
| 6. -24 VDC | 13. TORQUE COMMON |
| 7. +5.0 VDC | 14. TORQUE SIGNAL |

Figure 9–3 TSC2 Input Connector

3. Apply +0.000 VDC.
4. Press the ZERO button.
5. Adjust the ZERO by turning the Decrease/Increase dial until the displayed voltage equals the reference voltage (within 00.10 mV).



Note: The magnitude of change per revolution can be increased by pressing the UP ◀ button or decreased by pressing the DOWN ▶ button.

6. Apply 5.0 VDC.
7. Press the GAIN button.
8. Adjust the Decrease/Increase dial until the displayed voltage equals the reference voltage within 00.10 mV.

9.3.4 DAC OUTPUT OFFSET AND GAIN

1. Beginning in the TSC2 Offset and Gain screen, press SHIFT to proceed to the Calibration Output DAC Display Menu. The display should appear as follows:

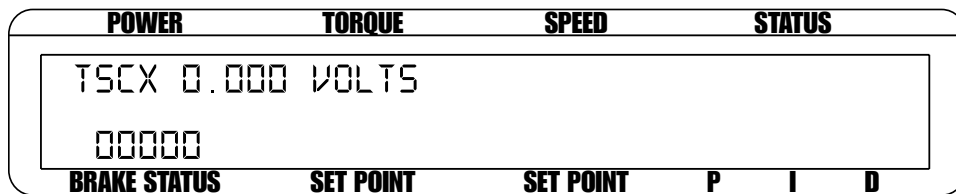
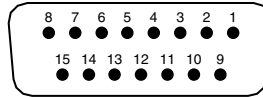

Figure 9–4 Calibration Output DAC Display Menu

2. Connect meter to Pin 14 (negative) and Pin 7 (positive) of SUPPLY 1 connector.

MAINTENANCE



- 1. SHIELD (EARTH)
- 2. ELECTRICAL ALARM CHANNEL 1
- 3. N/C
- 4. PRIMARY SUPPLY CONTR. CHANNEL 1
- 5. SUPPLY +24 VDC
- 6. +5.0 VDC COM
- 7. CURRENT SET POINT (SIGNAL)
- 8. W FLOW_1
- 9. SHIELD (EARTH)
- 10. TEMPERATURE ALARM CHANNEL 1
- 11. STAND-BY CHANNEL 1
- 12. SUPPLY +24 VDC
- 13. +5.0 VDC COM
- 14. CURRENT SET POINT (ANALOG 0V)
- 15. N/C

Figure 9–5 Supply 1 Connector

- 3. Using the Decrease/Increase dial, adjust the value so that the meter reading is 0.000 volts or within 00.20 mV.
- 4. Press SHIFT once.
- 5. Connect meter to Pin 14 (negative) and Pin 7 (positive) of SUPPLY 2 connector.

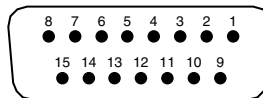

- 1. SHIELD (EARTH)
- 2. ELECTRICAL ALARM CHANNEL 2
- 3. CLUTCH
- 4. PRIMARY SUPPLY CONTR. CHANNEL 2
- 5. SUPPLY +24 VDC
- 6. +5.0 VDC COM
- 7. CURRENT SET POINT (SIGNAL)
- 8. W FLOW_2
- 9. SHIELD (EARTH)
- 10. TEMPERATURE ALARM CHANNEL 2
- 11. STAND-BY CHANNEL 2
- 12. SUPPLY +24 VDC
- 13. +5.0 VDC COM
- 14. CURRENT SET POINT (ANALOG 0V)
- 15. N/C

Figure 9–6 Supply 2 Connector

- 6. Using the Decrease/Increase dial, adjust the value so that the meter reading is 0.000 volts or within 00.20 mV.
- 7. Press SHIFT once. The display should appear as follows:

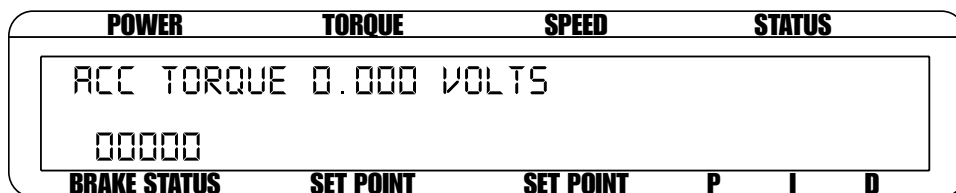
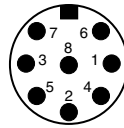

Figure 9–7 Calibration Accessory Torque DAC Display Menu

MAINTENANCE

8. Connect volt meter to Pin 3 (negative) and Pin 1 (positive) of ACCESSORY TORQUE-SPEED OUTPUT.



1. ANALOG TORQUE
2. ANALOG SPEED
3. ANALOG GROUND
4. ALARM RELAY (NORMALLY OPEN)
5. ALARM RELAY (NORMALLY CLOSED)
6. ALARM RELAY (COMMON)
7. EXTERNAL ALARM INPUT
8. +5.0 VDC COM

Figure 9–8 Accessory Torque-Speed Output

9. Using the Decrease/Increase dial, adjust the value so that the meter reading is 0.000 volts or within 00.20 mV.
10. Press SHIFT once.
11. Using the Decrease/Increase dial, adjust the value so that the meter reading is 9.000 volts or as close as possible.
12. Press SHIFT once. The display should appear as follows:

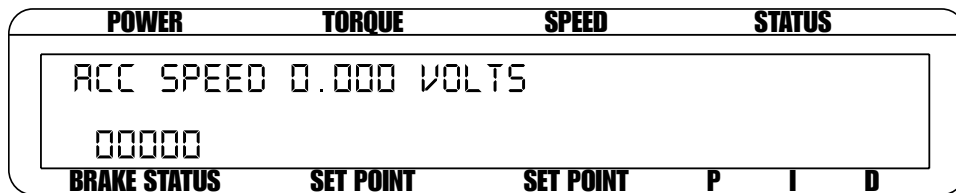

Figure 9–9 Calibration Accessory Speed DAC Display Menu

13. Connect volt meter to Pin 3 (negative) and Pin 2 (positive) of the ACCESSORY TORQUE-SPEED OUTPUT.
14. Using the Decrease/Increase dial, adjust the value so that the meter reading is 0.000 volts or within 00.20 mV.
15. Press SHIFT once.
16. Using the Decrease/Increase dial, adjust the value so that the meter reading is 9.000 volts or as close as possible.
17. Press SHIFT once to end calibration and return to main menu.

9.3.5 SPEED CHECK

1. Connect a function generator with square wave TTL output to pins 10 (TACH. A) and 8 (+5.0 VDC COM) of the 14-pin TSC1 connector. For reference, see *Figure 9–2 TSC1 Input Connector*.
2. Verify that the speed display reads the same value as the function generator frequency.
3. If the speed display does not read the same value as the function generator, call Magtrol customer service.



Note: There are no adjustments for speed calibration.

MAINTENANCE

9.3.6 DECIMAL POINT CHECK

1. Connect a 0.5 VDC source to pins 14 (TORQUE SIGNAL) and 13 (TORQUE COMMON) of the 14-pin TSC1 connector. For reference, see *Figure 9–2 TSC1 Input Connector*.
2. Verify that the torque display reads 500.0.
3. Connect pin 9 (D.P. A) to pin 8 (+5.0 VDC COM).
4. Verify that the torque display reads 50.0.
5. Disconnect pin 9 from pin 8.
6. Connect pin 12 (D.P. B) to pin 8 (+5.0 VDC COM).
7. Verify that the torque display reads 5.000.
8. If the torque display does not show correct readings, call Magtrol Customer Service.



Note: There are no adjustments for decimal point location.

10. Troubleshooting

Problem	Reason	Solution
Display indicates I/O ERROR.	Command does not match the unit's programmed set of instructions.	Use correct command and format.
Speed command sent, but Controller does not respond.	Communication occurred but the Controller is not loading the motor.	Adjust PID values.
Mechanical power reads much higher or lower than expected	Torque units are incorrect.	Set torque input units to match the specifications on dynamometer nameplate.
No GPIB communication.	Setup error and/or hardware fault.	Check: <ul style="list-style-type: none"> • GPIB address of Controller. • GPIB cable - should be functioning and attached to Controller and computer interface card.
No RS-232 communication.	Setup error and/or hardware fault.	Check: <ul style="list-style-type: none"> • Baud rate of Controller. • Pinout of serial cable. • Cable attachment to Controller and serial interface port of computer.
Dynamometer shaft does not turn smoothly when BRAKE is OFF.	Salient poles were set up on the rotor by having brake current applied with no shaft rotation.	Start the motor and bring up to speed. Press BRAKE button ON. Adjust output current up to a value at least 25% of the maximum torque rating of the dynamometer in use (if possible). Reduce output current to 0.
Dynamometer loads too quickly causing motor to stall.	Input units are improperly set up.	Set torque input units to match specifications on dynamometer nameplate.
Speed not reading correctly.	Speed encoder is improperly set up.	Set speed encoder bits to match specifications on dynamometer nameplate.

If you require additional assistance, please contact Magtrol Customer Service at 1-716-668-5555.

Appendix A: LabVIEW Programming Examples

Magtrol offers a comprehensive motor testing software program to satisfy most of your programming needs. To order your software, call Magtrol Sales at 1-716-668-5555.

A.1 SIMPLE READ

While Loop

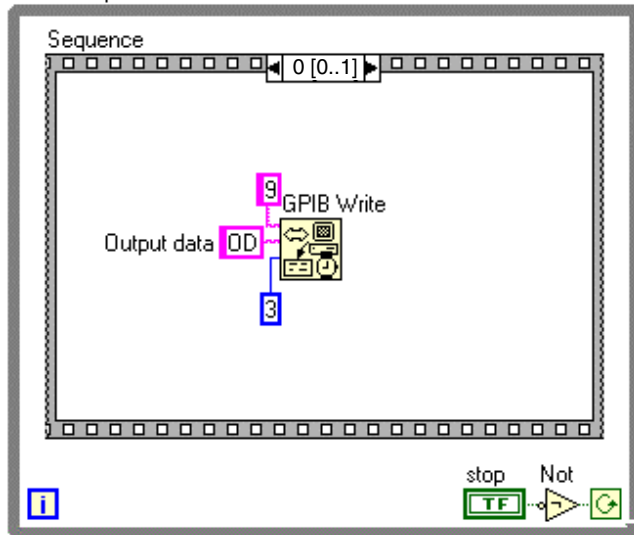

while Loop

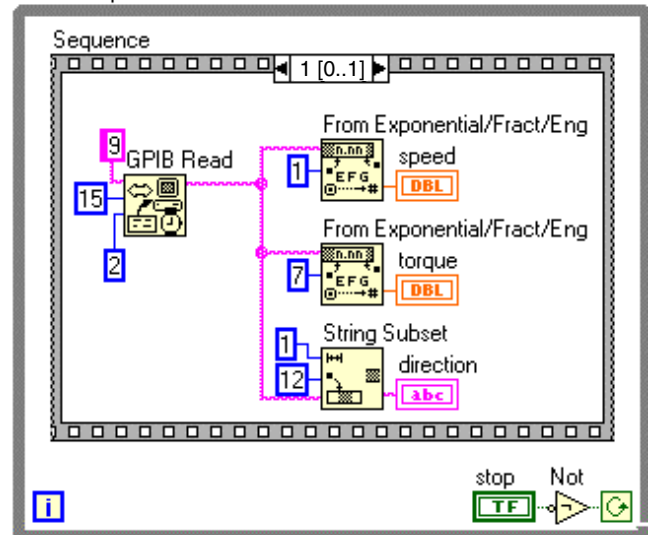

A.2 TORQUE STABILIZED

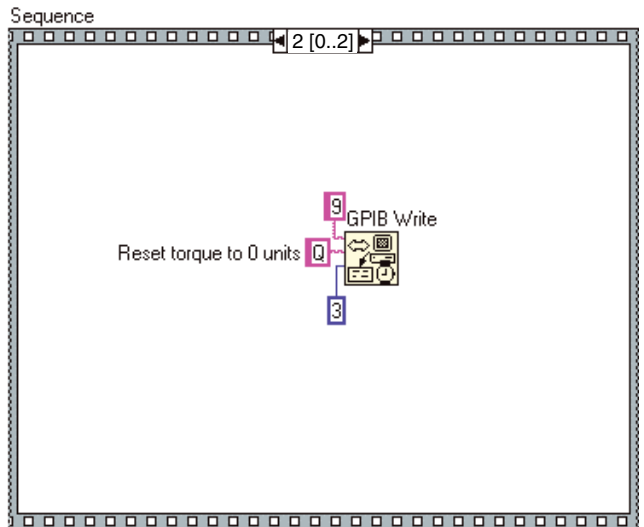
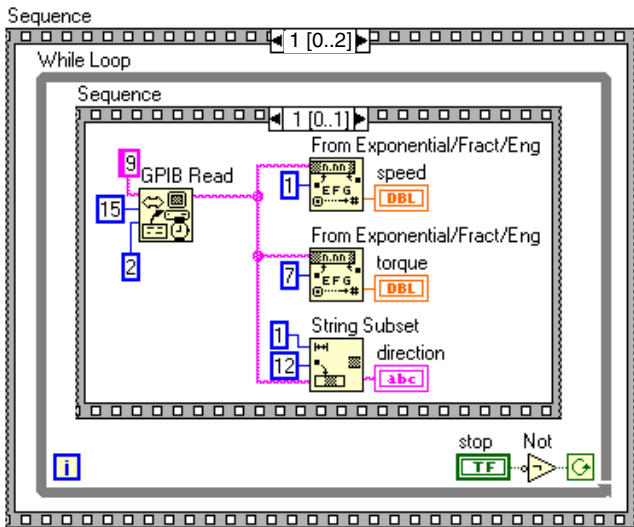
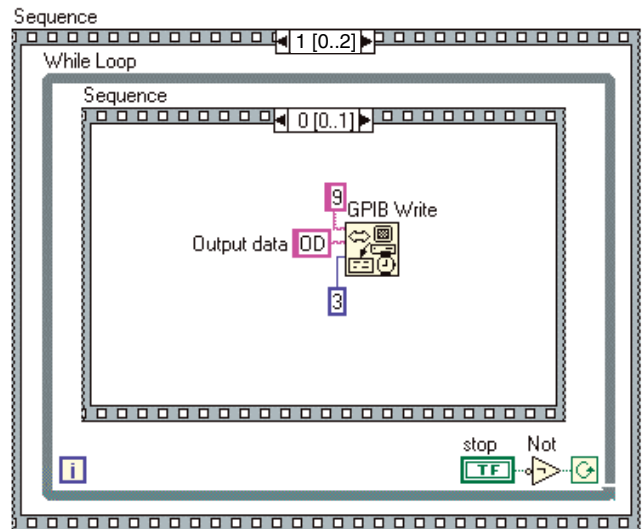
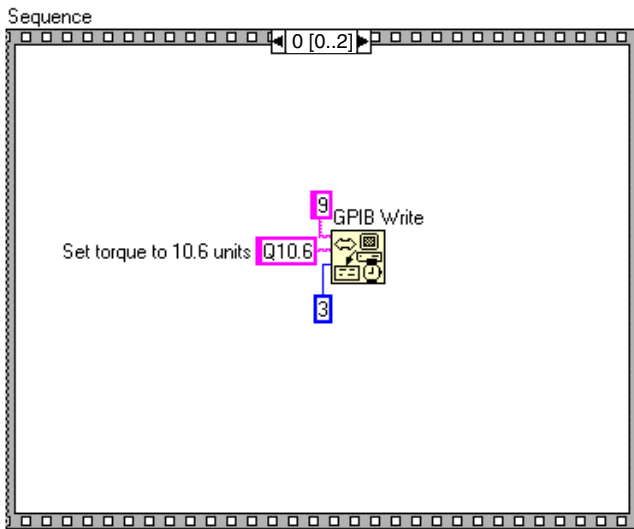

A.3 SPEED STABILIZED

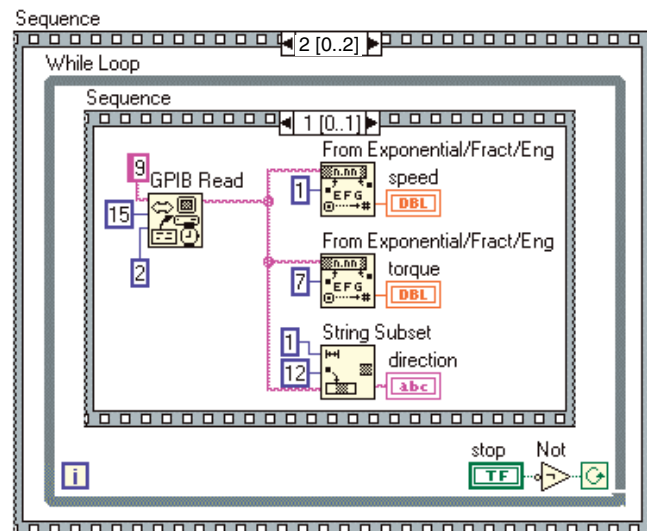
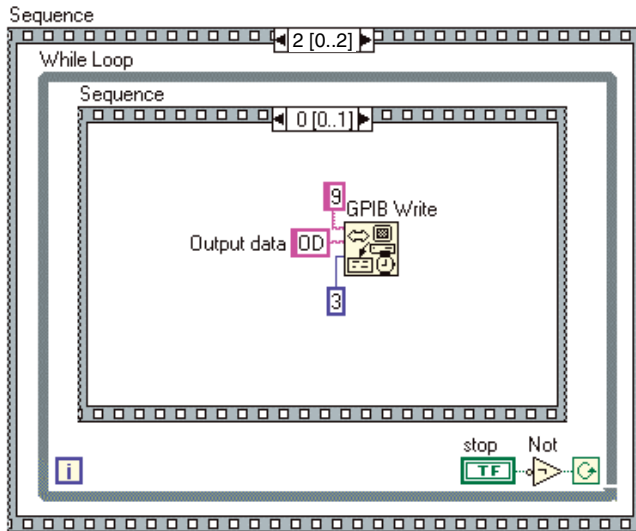
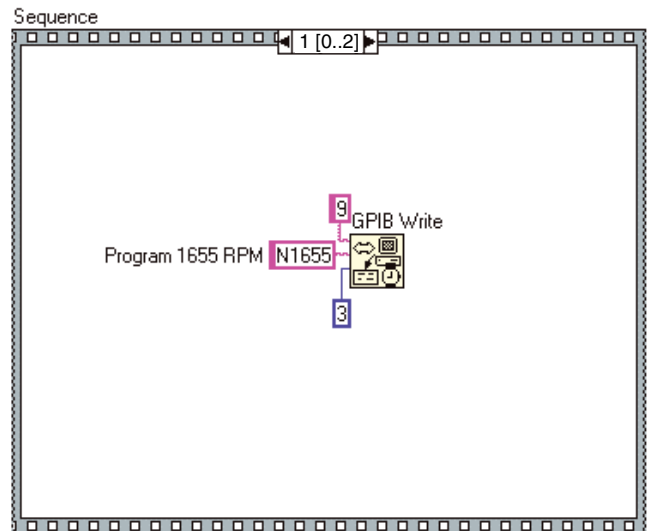
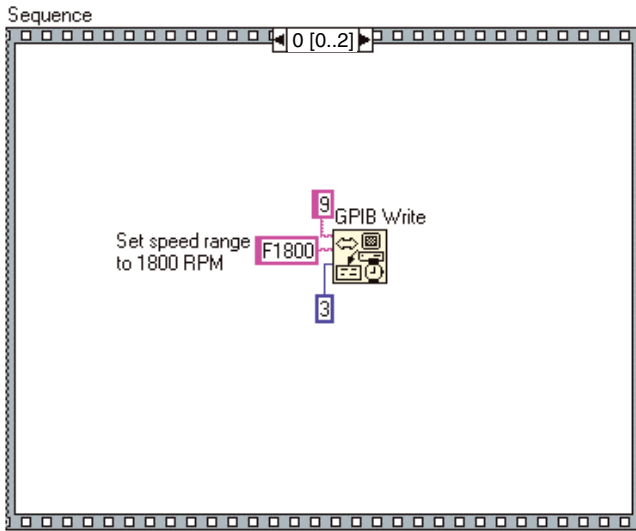

Appendix B: Inertia Correction

B.1 INERTIAL EFFECT ON MOTOR TEST DATA

A major advantage of the DSP6001 is its ability to obtain full motor performance data (free run to locked rotor) by continuous load application with an absorption dynamometer. Data acquisition is fast, resulting in minimal motor I^2R losses, and loading characteristics simulate actual end-use applications.

When a motor is accelerating or decelerating, the measured torque is the sum of the true motor torque \pm the inertial torque or stored energy of the system. Unless inertial torque is excluded, motor performance will vary in proportion to the rate of acceleration or deceleration.

This type of error can produce problematic test results. For example, during rapid deceleration, system inertia can produce apparent efficiency greater than 1.0. This error may occur if output power is divided by input power without extracting the stored energy in the system.

Since “inertial effect” is only a factor when speed is changing, and because inertial torque is proportional to the rate of change, inertial value may be expressed as a unit of torque *per* change in rpm *in a given period of time*. With the DSP6001, properly adjusted PID values yield constant change in rpm so that the inertial torque can be expressed as a constant.

B.2 PROCEDURE FOR INERTIA CORRECTION

1. Determine the torque Correction Factor (CF) as follows:
 - Adjust the PID loop properly
 - Establish a torque value equal to the inertial torque.
2. Use the “Program Down” command (PD#) to ramp to 75% of the free-run speed.
3. Select a data point on the performance curve where speed will be approximately 78% of the free-run speed. Let this represent the dynamic speed-torque value.
4. Immediately program your DSP6001 (Nddddd) to a speed equal to the dynamic speed value. When the speed stabilizes, use this as the *static torque value*.

$$CF = \text{Dynamic Torque} - \text{Static Torque}$$

To correct your data, subtract the CF from each torque point obtained during the ramp.

Example:

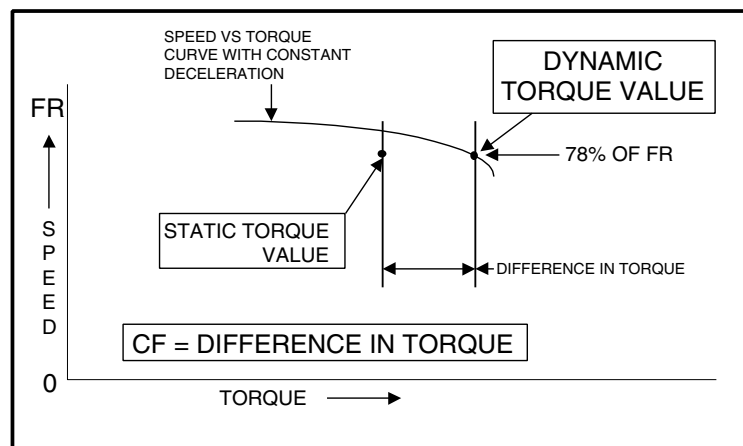

B.2.1**KEY CONDITIONS**

- **Select appropriate value.** The test point selection of 78% is typical for an induction motor. Use a value in the linear portion of the motor curve where there is a substantial torque change with speed.
- **Acquire data rapidly.** Rapid data acquisition is necessary so that motor heating does not degrade performance by adding a false difference between the static and dynamic torque values.
- **Use a regulated power source.** The input line voltage must be stable for the time necessary to perform the test. Torque varies by the square of the change in line voltage.
- **Obtain new CF value for various deceleration/ acceleration rates.** The CF is only valid for its specific ramp rate. To calculate other CF rates, use the following equation:

$$CF_{\text{new}} = (CF_{\text{old}} / \text{ramp rate}) \times \text{new ramp rate}$$

Appendix C: Front Panel/Display Menu Flow Charts

The following flow charts are a reference for navigating through the key functions of the DSP6001 Dynamometer Controller. For step-by-step setup instructions, refer to the corresponding chapters in this manual.

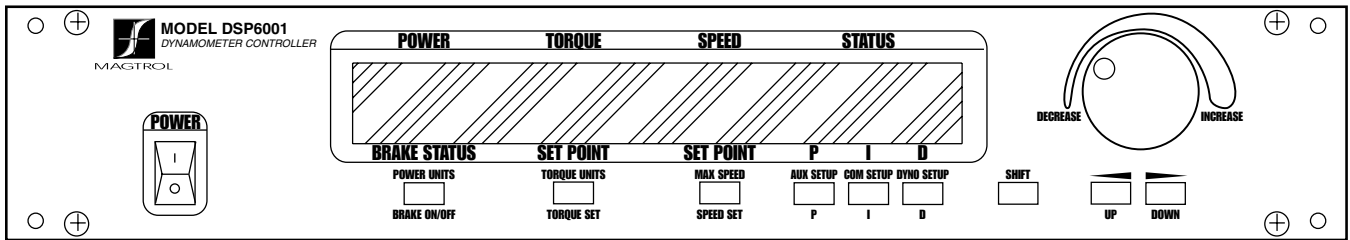

C.1 PRIMARY KEY FUNCTIONS

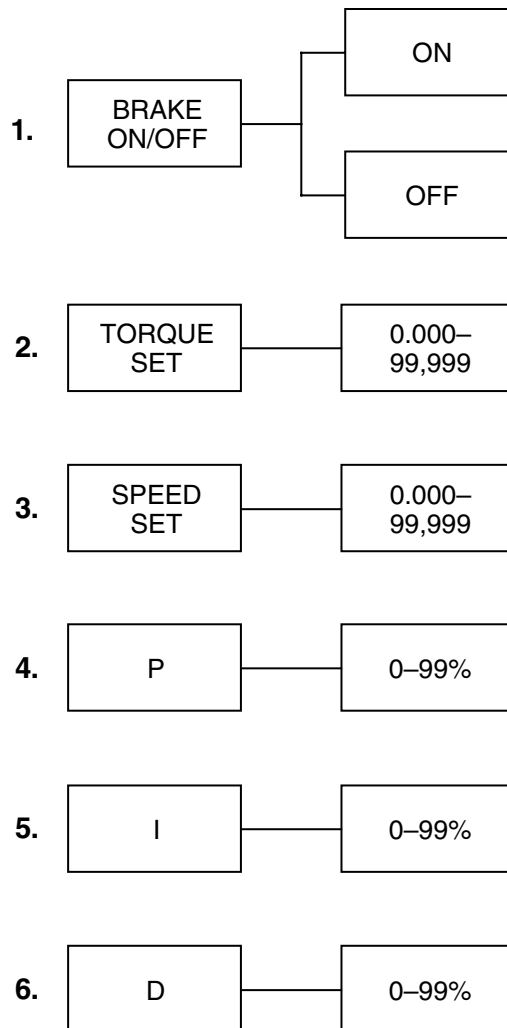

C.2 SECONDARY KEY FUNCTIONS

C.2.1 POWER UNITS MENU

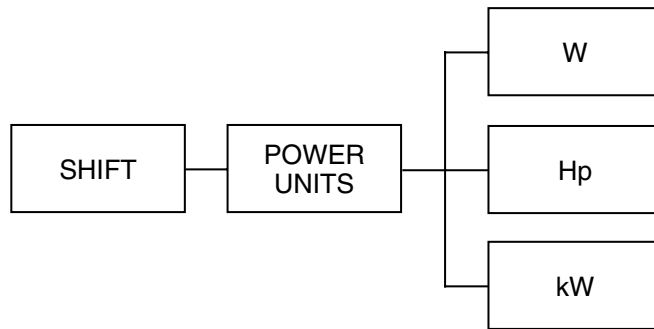

C.2.2 TORQUE UNITS MENU

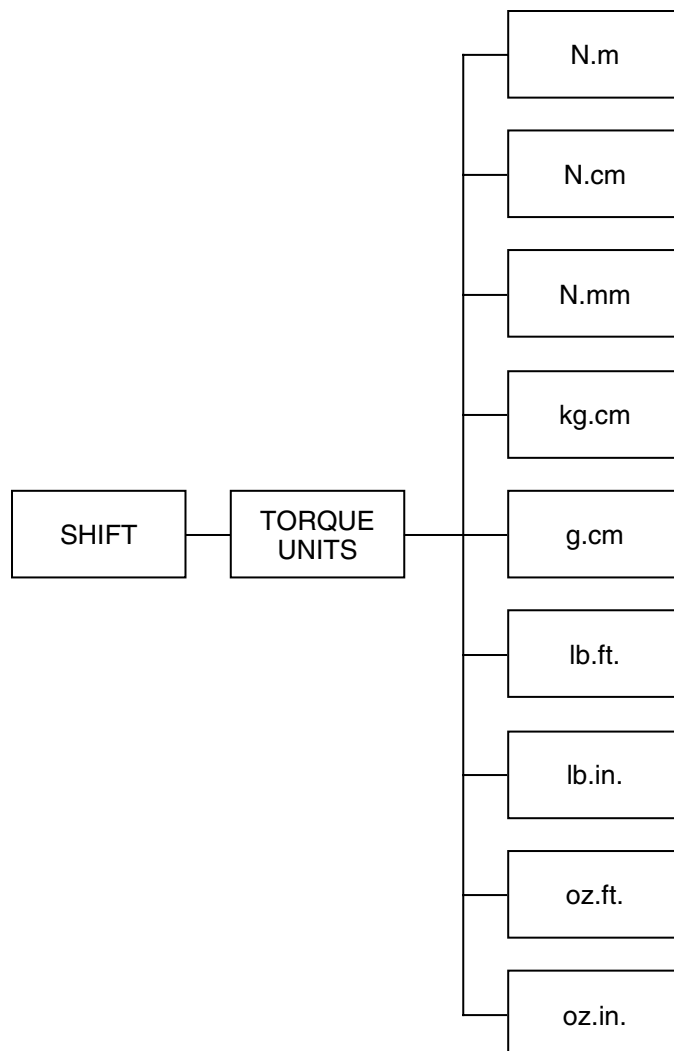

C.2.3 MAX SPEED MENU



C.2.4 AUX SETUP MENU

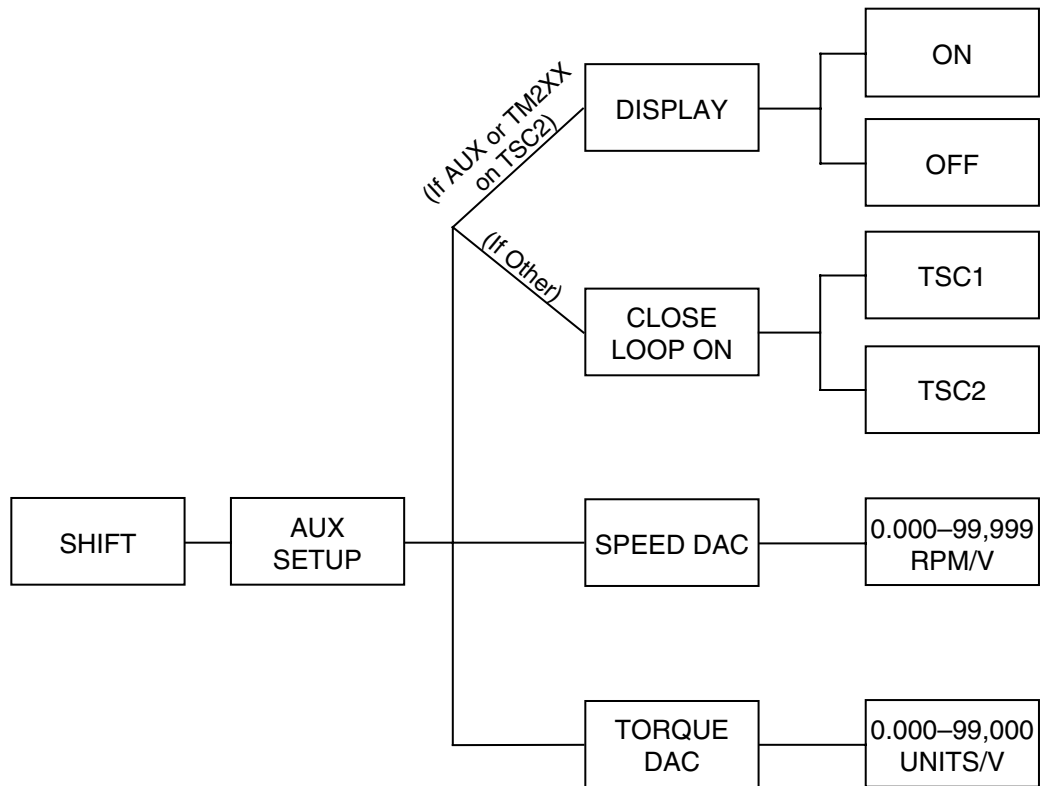

C.2.5 COM SETUP MENU

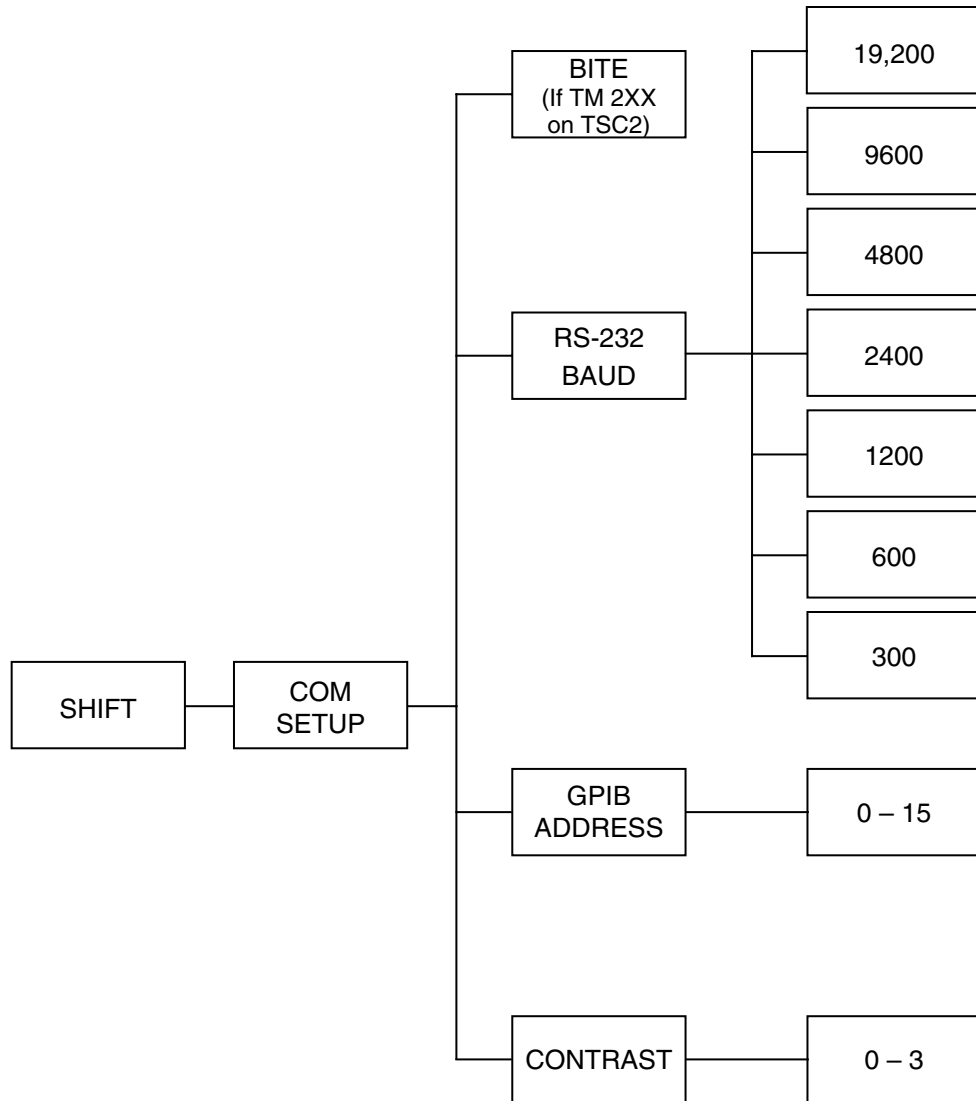

C.2.6 DYNO SETUP MENU

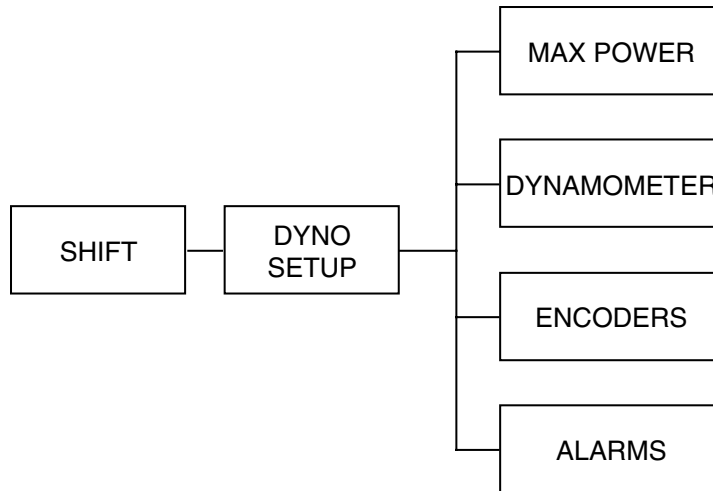

Note: Refer to the flow charts on the following pages for a more detailed breakdown of MaxPower, Dynamometer, Encoders and Alarms.

C.2.6.1 MaxPower Setup Menu

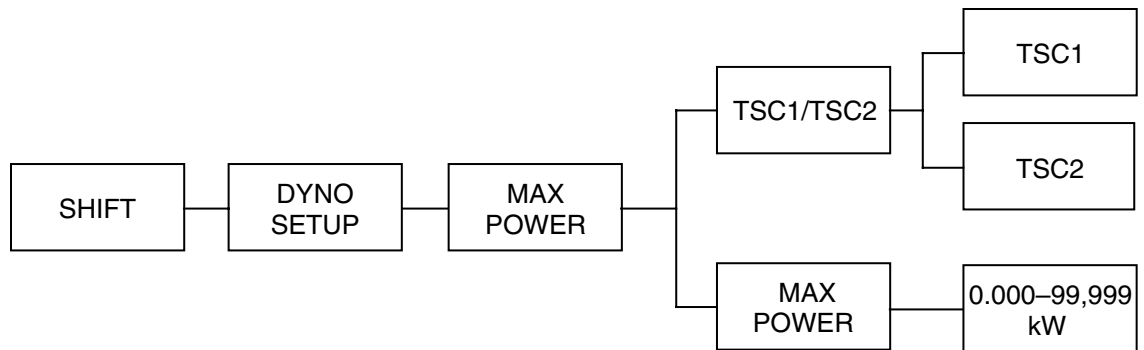

C.2.6.2 Dynamometer Configuration Menu

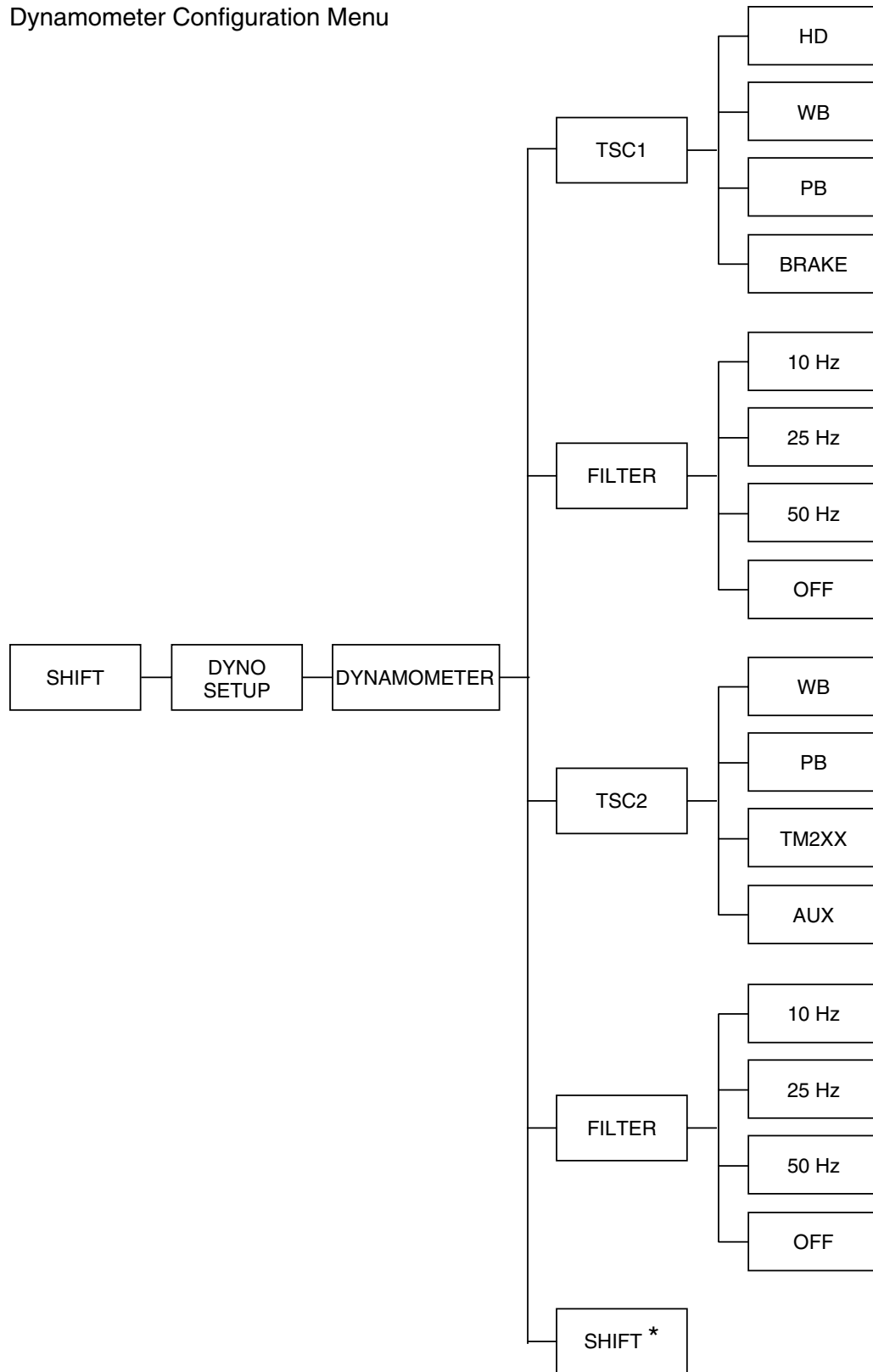

Note: Refer to flow charts C.2.6.2A through C.2.6.2H for a more detailed breakdown based on test instrument selection. All flow charts will be a continuation of C.2.6.2 beginning at SHIFT*.

C.2.6.2A Hysteresis Dynamometer Setup Menu

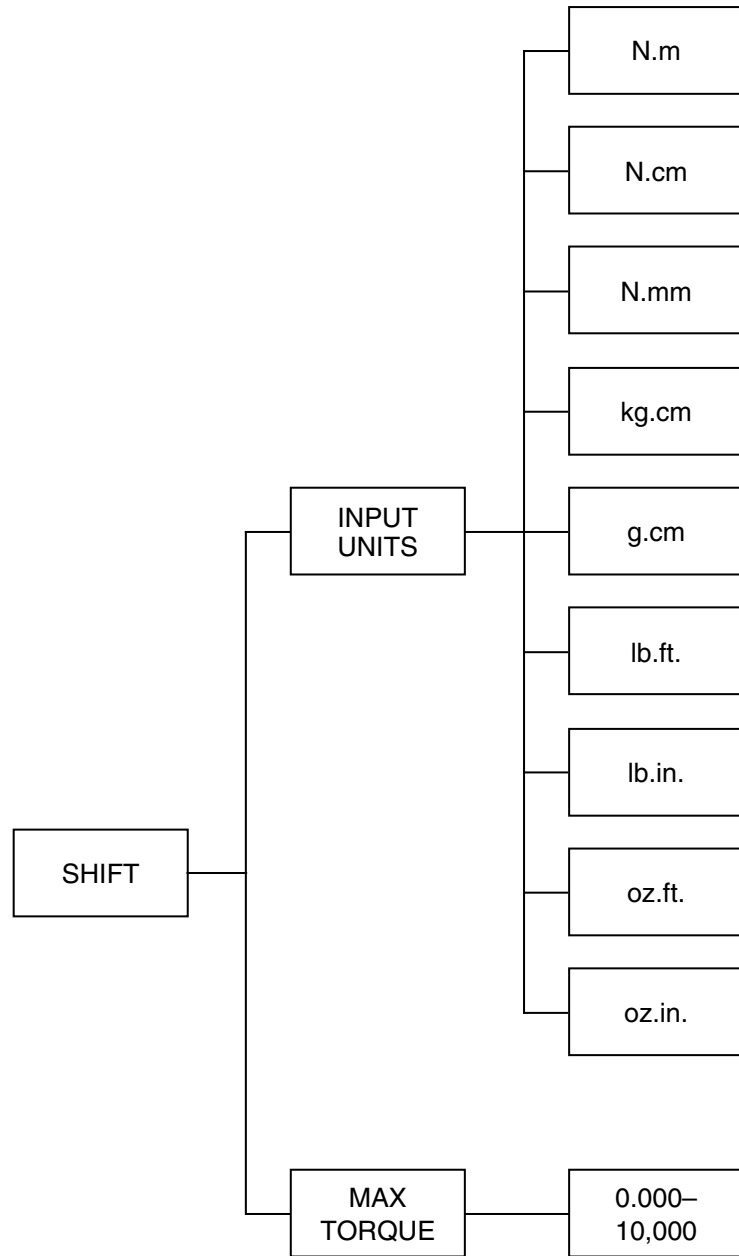

C.2.6.2B Torque Transducer Setup Menu

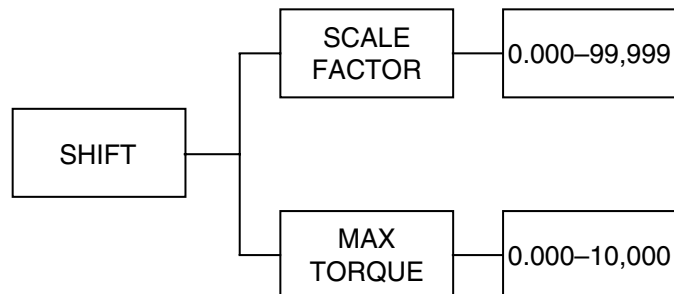

C.2.6.2C Aux Setup Menu

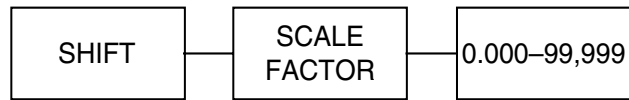

C.2.6.2D Eddy-Current Dynamometer Setup Menu

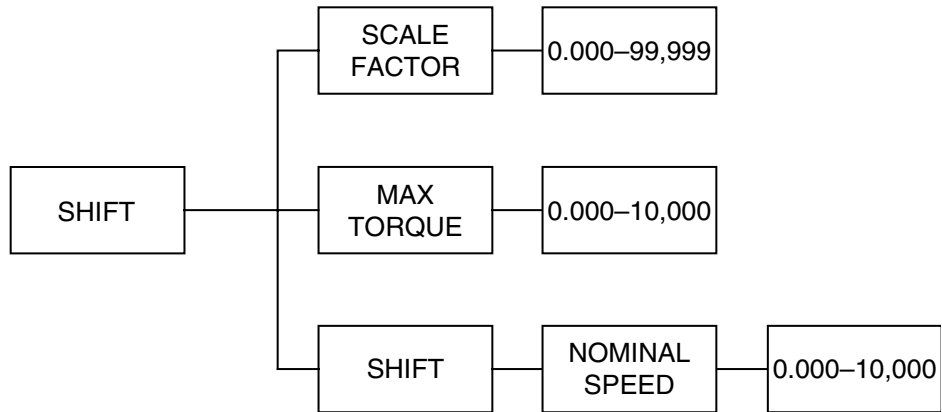

C.2.6.2E Powder Dynamometer Setup Menu

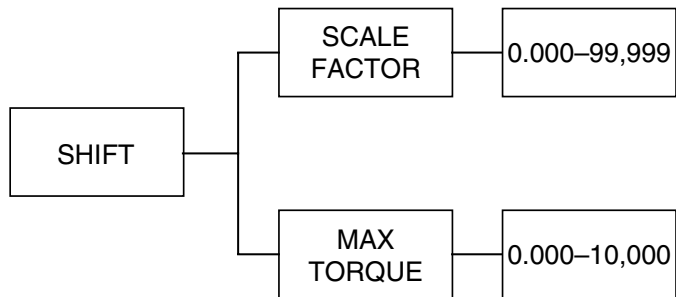

C.2.6.2F Eddy-Current Dynamometer with Eddy-Current Dynamometer (Tandem Setup)

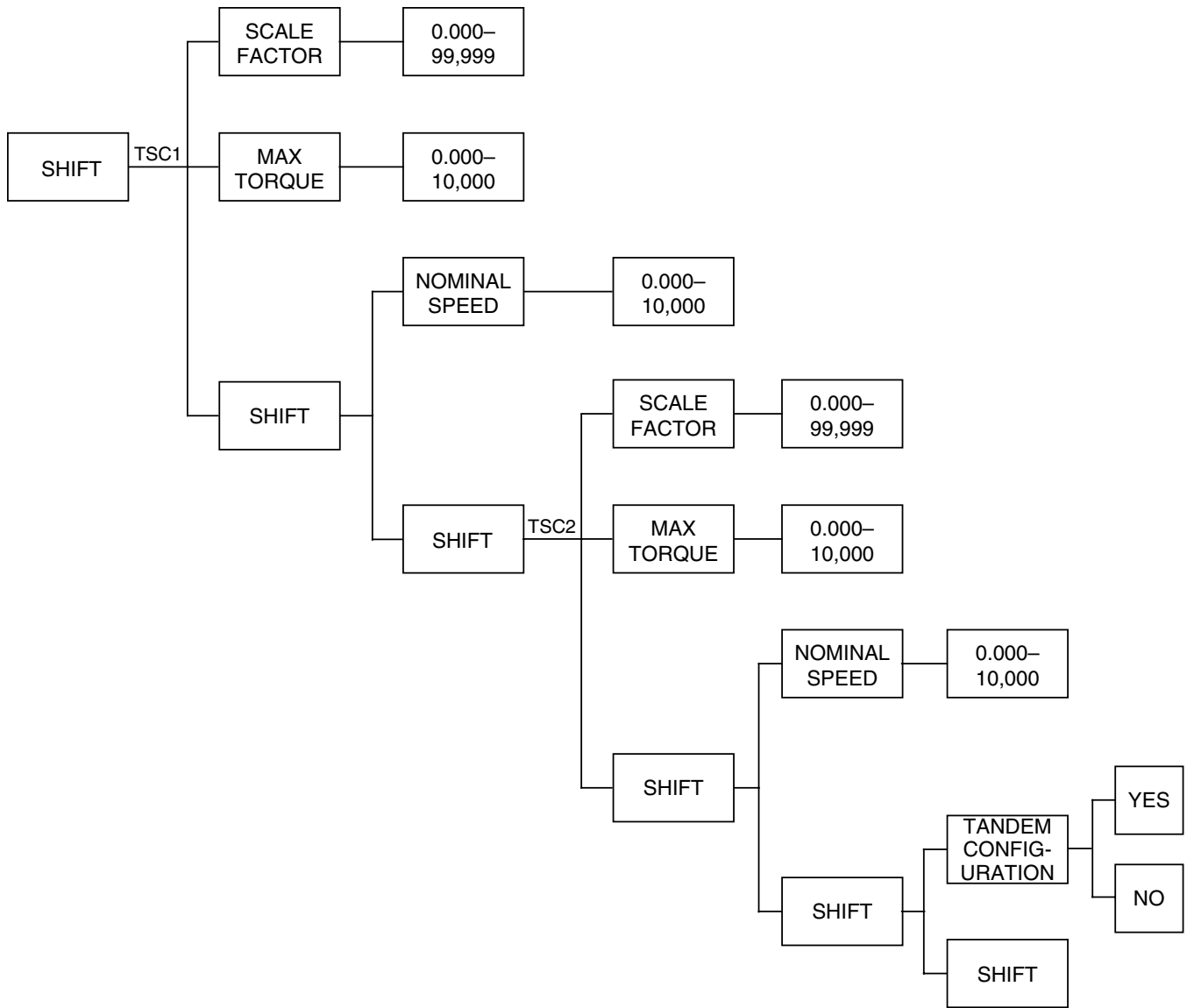

C.2.6.2G Powder Brake Dynamometer with Powder Brake Dynamometer (Tandem Setup)

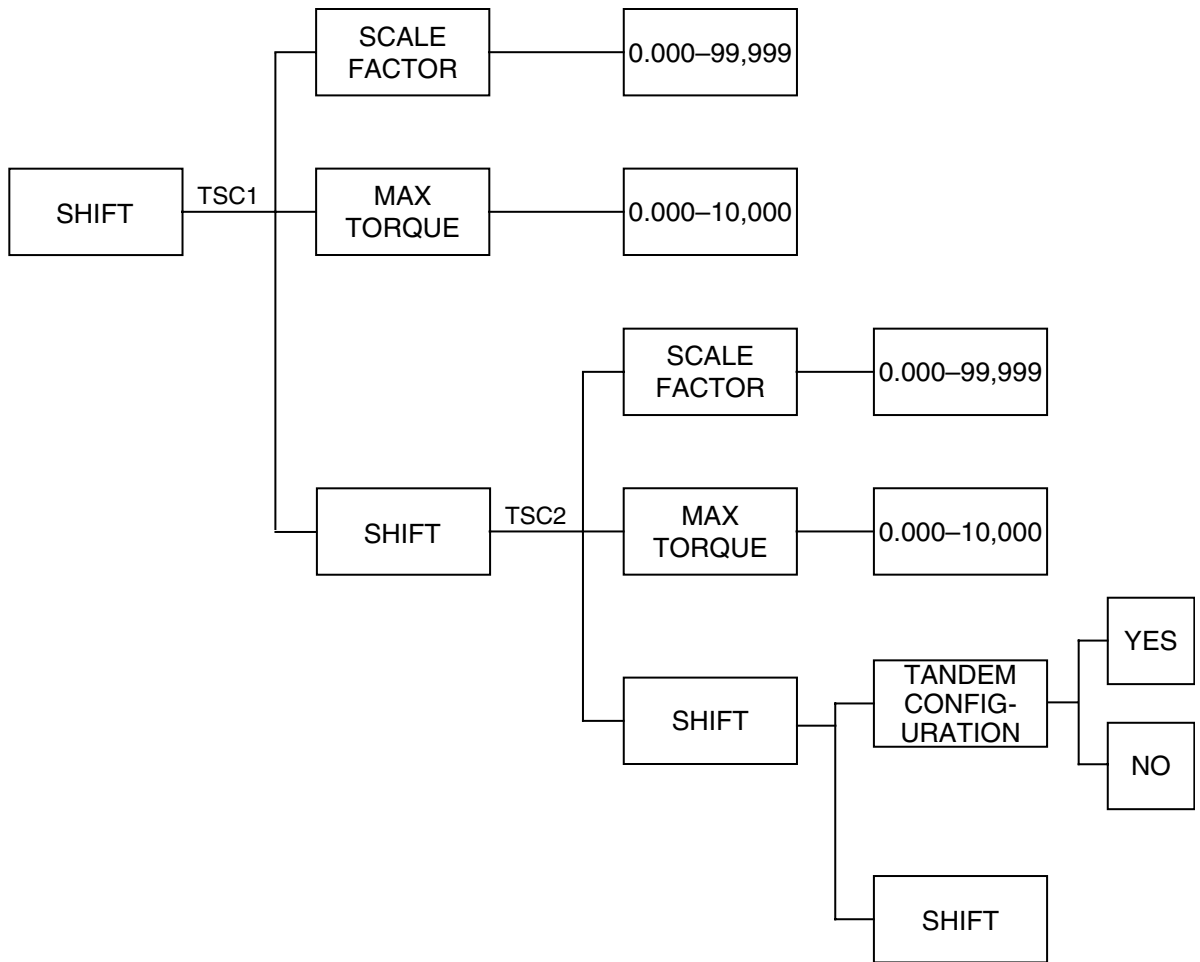

C.2.6.2H Eddy-Current Dynamometer with Powder Brake Dynamometer (Tandem Setup)

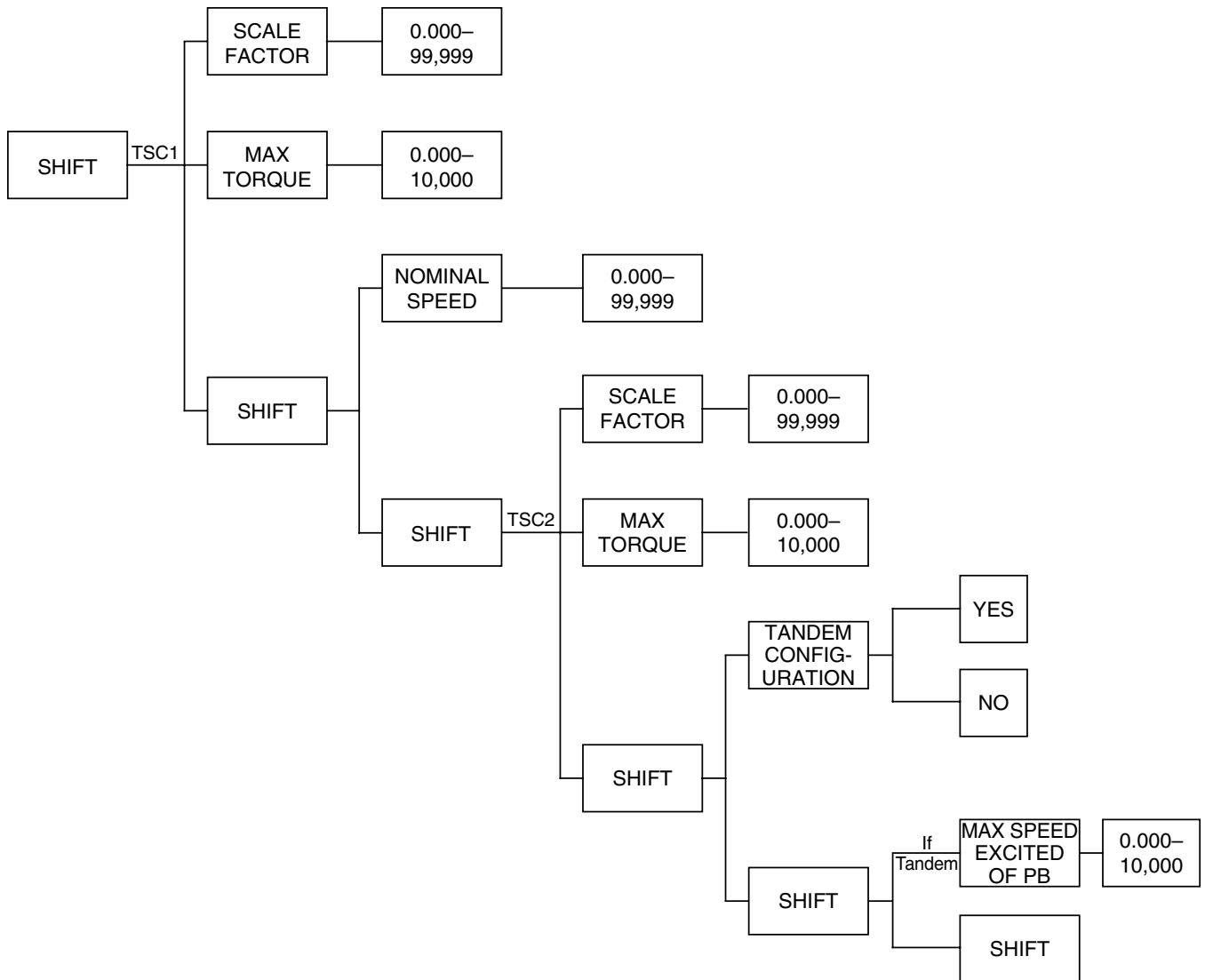

C.2.6.3 Encoder Setup Menu

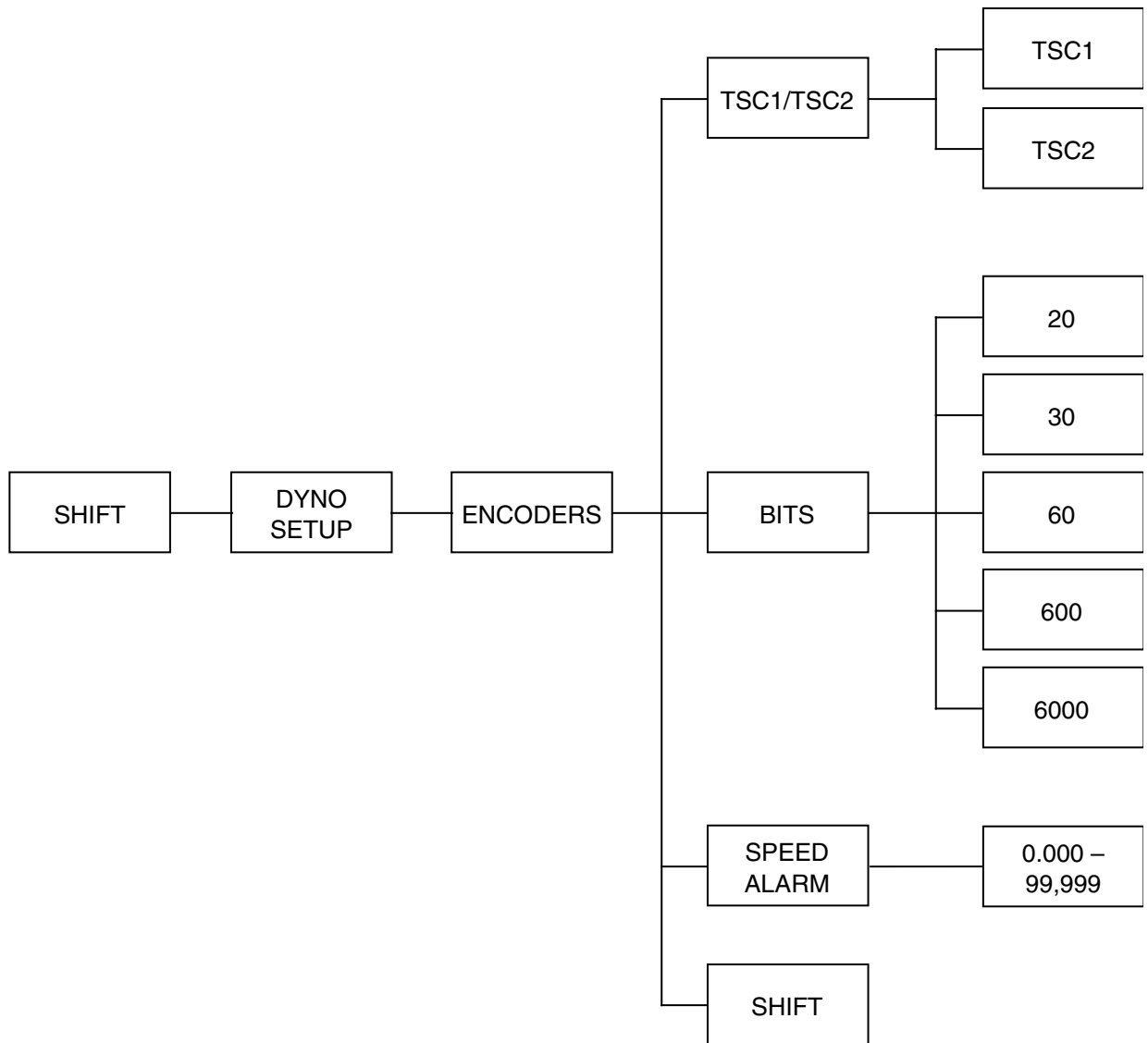

C.2.6.4 Alarm Setup Menu

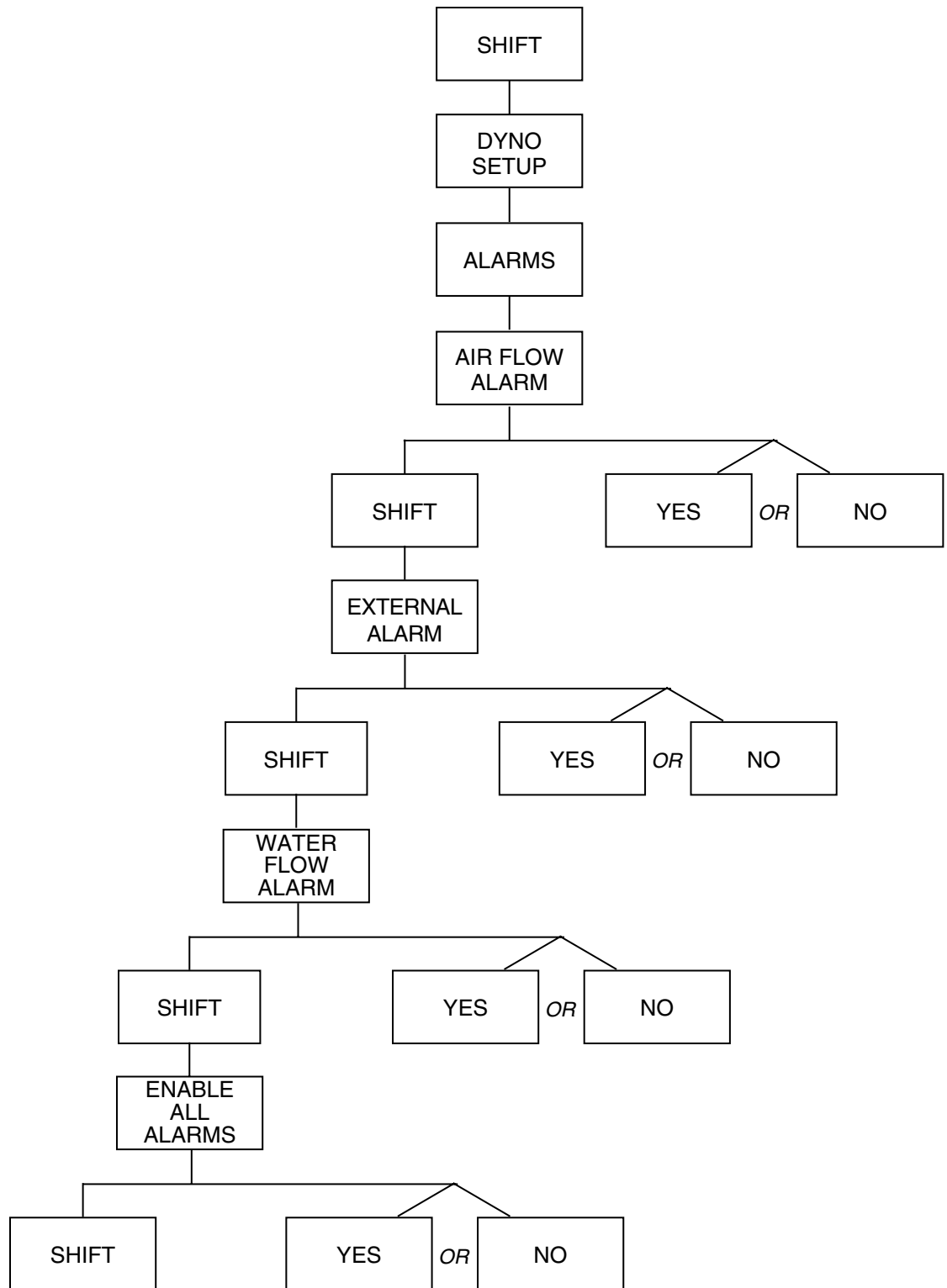

Appendix D: Remote Configuration Flow Charts

D.1 ADVANCED CONFIGURATION

TSC not selected yet

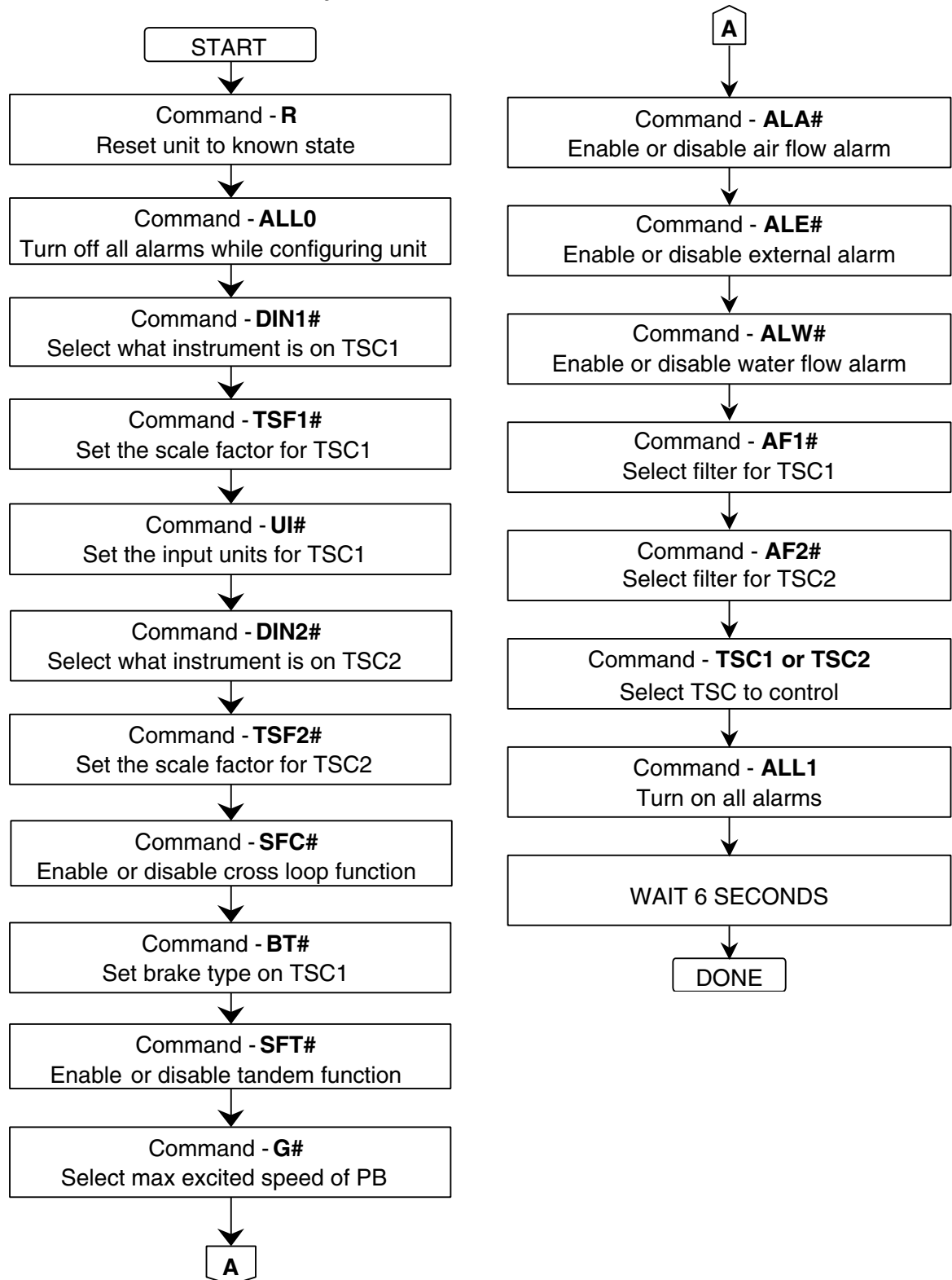

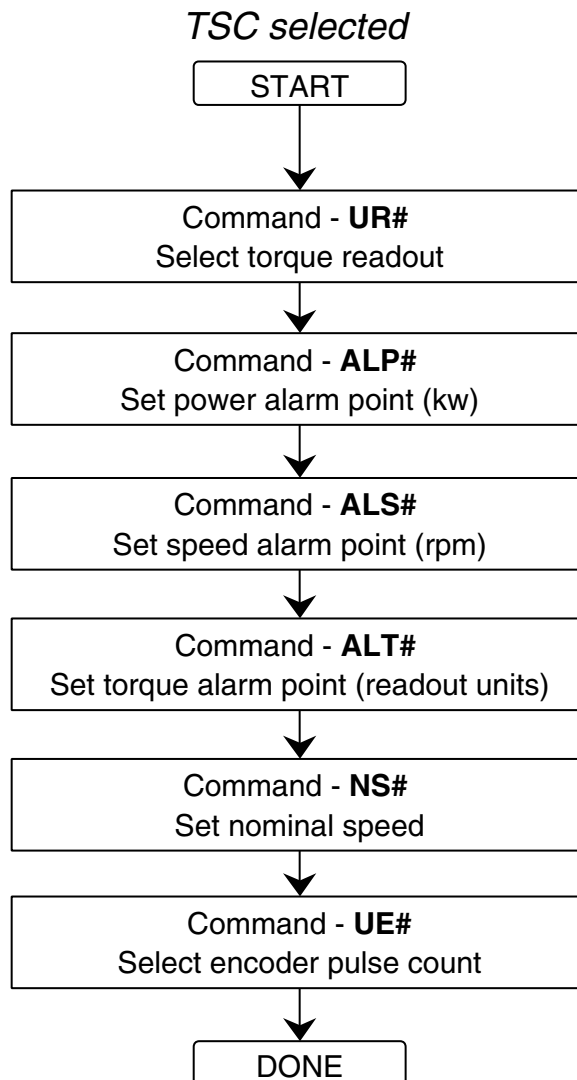
D.2 PRE-TEST

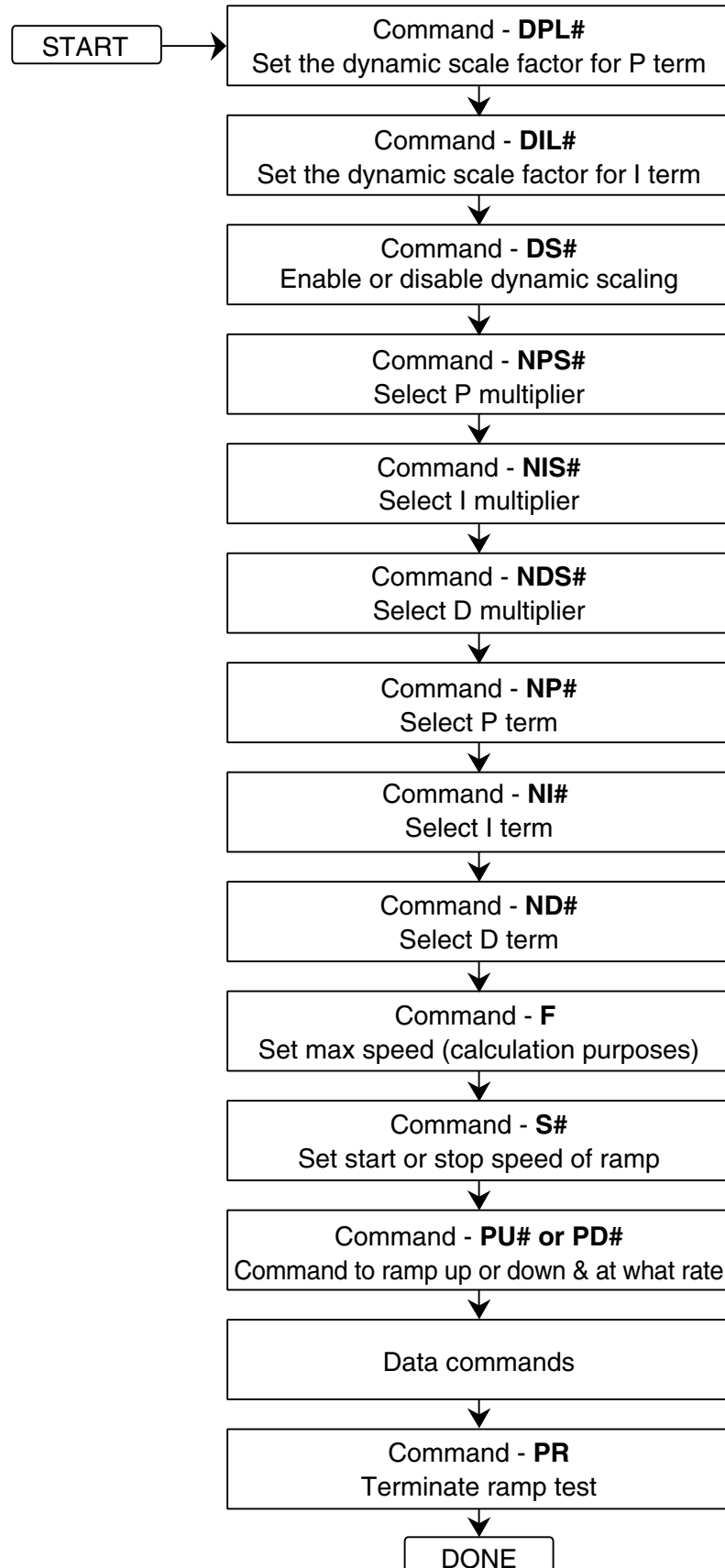
D.3 RAMP

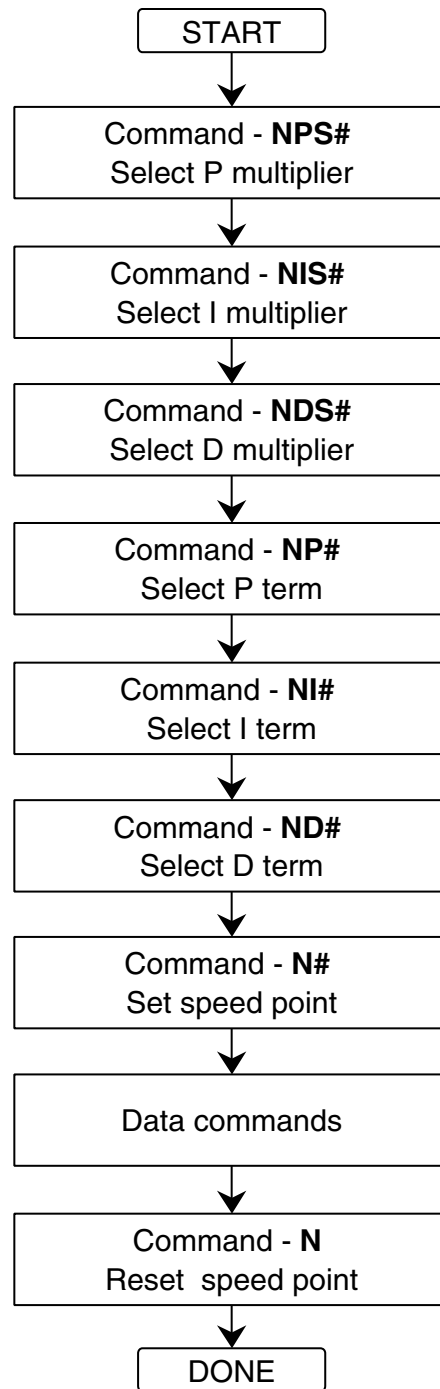
D.4 SPEED

D.5 TORQUE

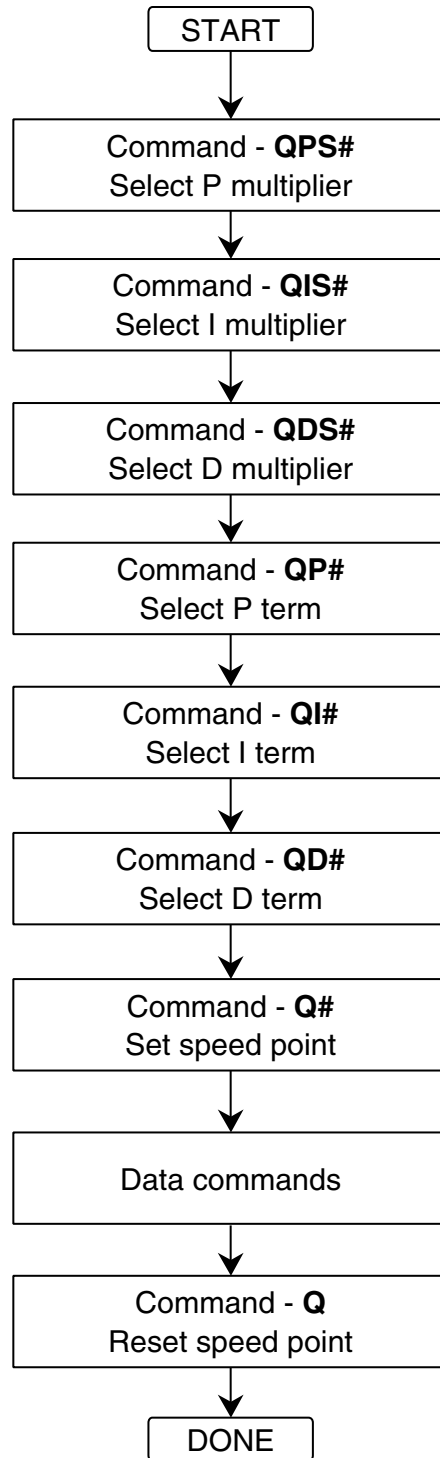

D.6 MISCELLANEOUS

Command - **DIR#**
Selects quadrature input or single frequency

Command - **OH1**
Returns quadrature counter values

Command - **IOXX.XX**
Applies offset to output DAC on channel 1

Command - **I#**
Set current to #

Command - **X**
Returns the % current value

Command - **SAVE**
Save configuration to NVM

D.7 DATA

Command - **OD**
Request torque and speed
of TSC under control

Command - **OA**
Request output of TSC2 torque
in Nm for TM2XX or AUX input

Command - **OR**
Request rotation direction of TM2XX

Appendix E: Schematics

E.1 DYNAMOMETER POWER SUPPLY

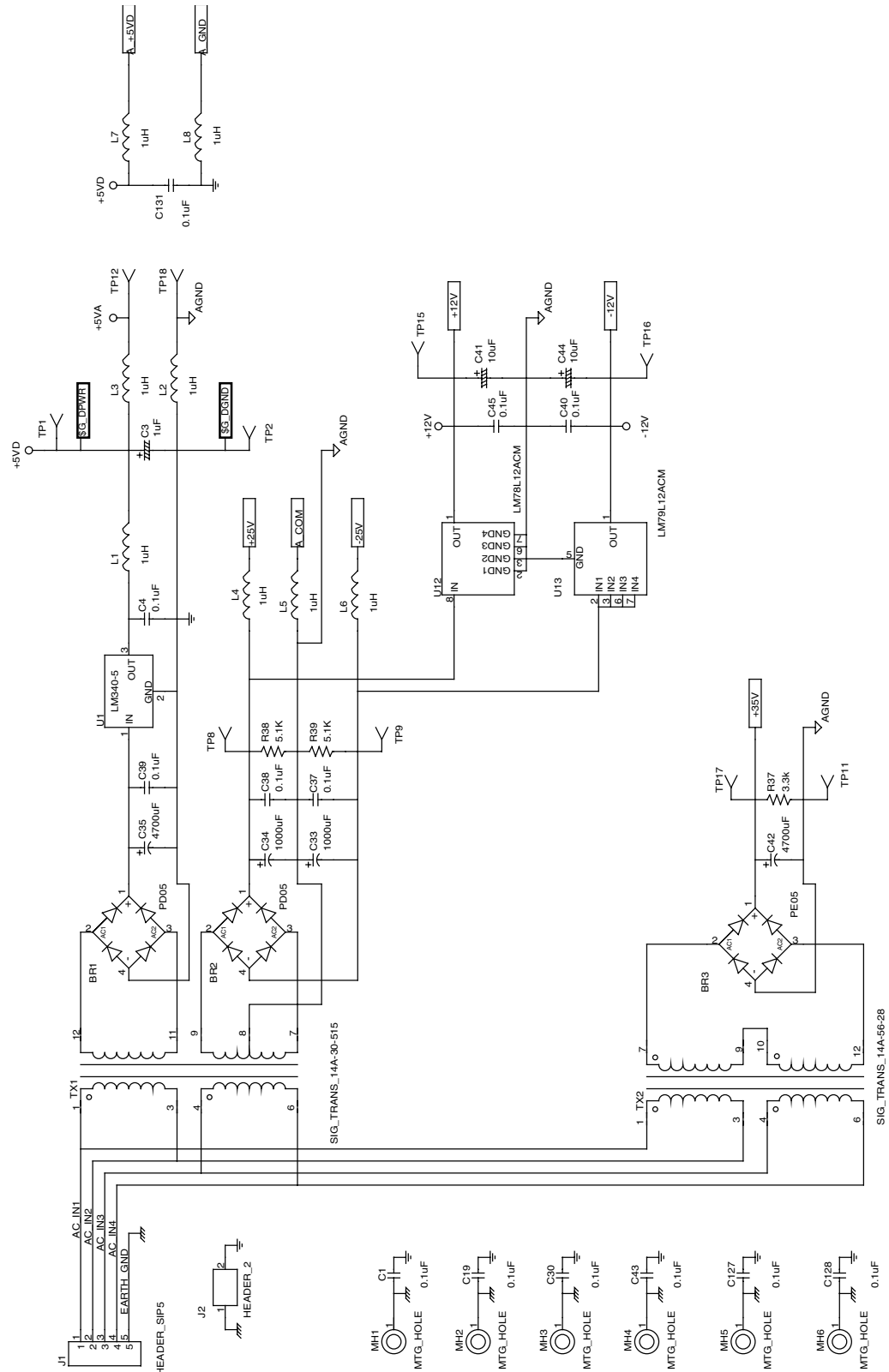

E.2 DYNAMOMETER DSP & MEMORY

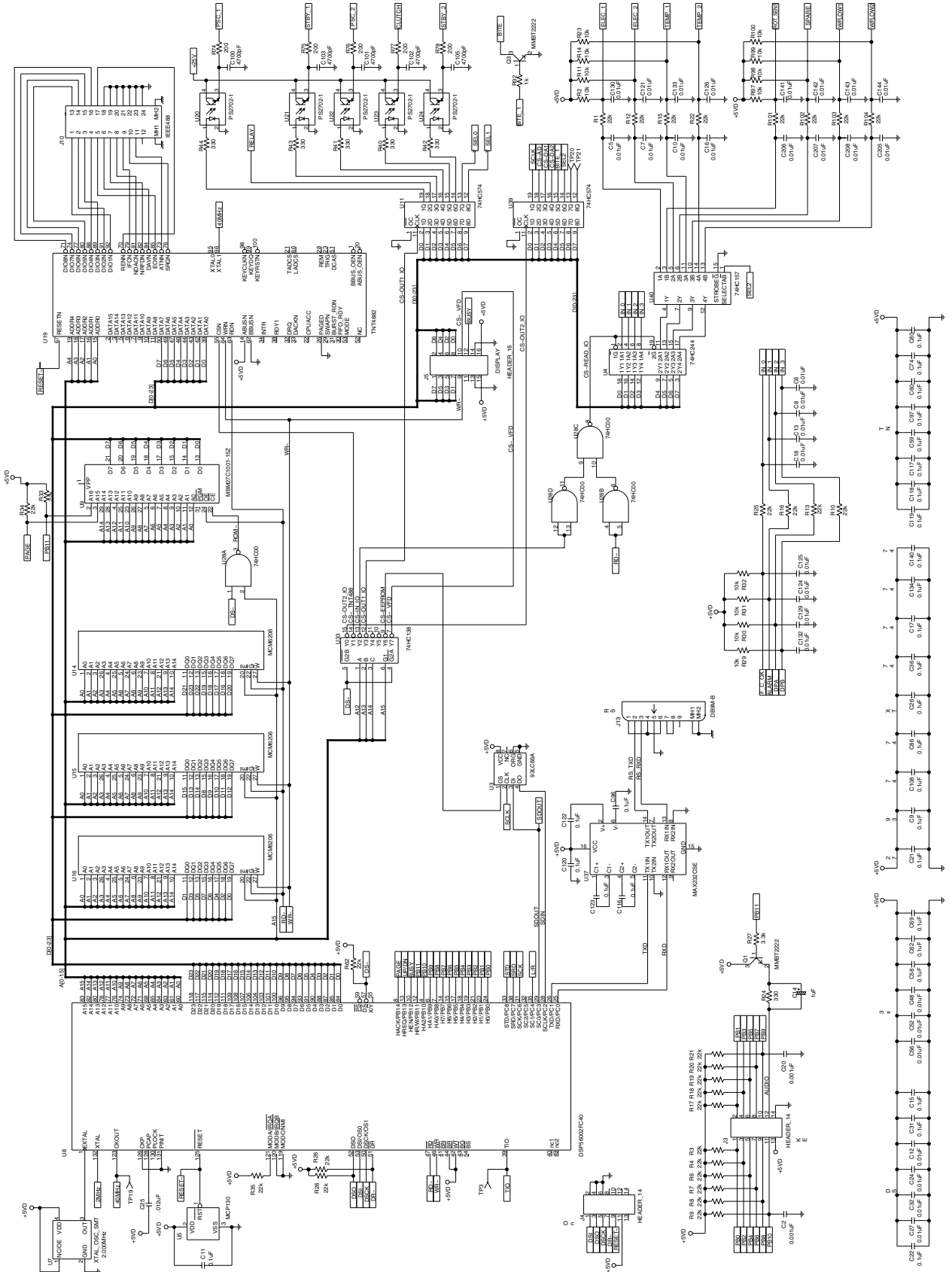

E.3 DSP DYNAMOMETER ANALOG I/O

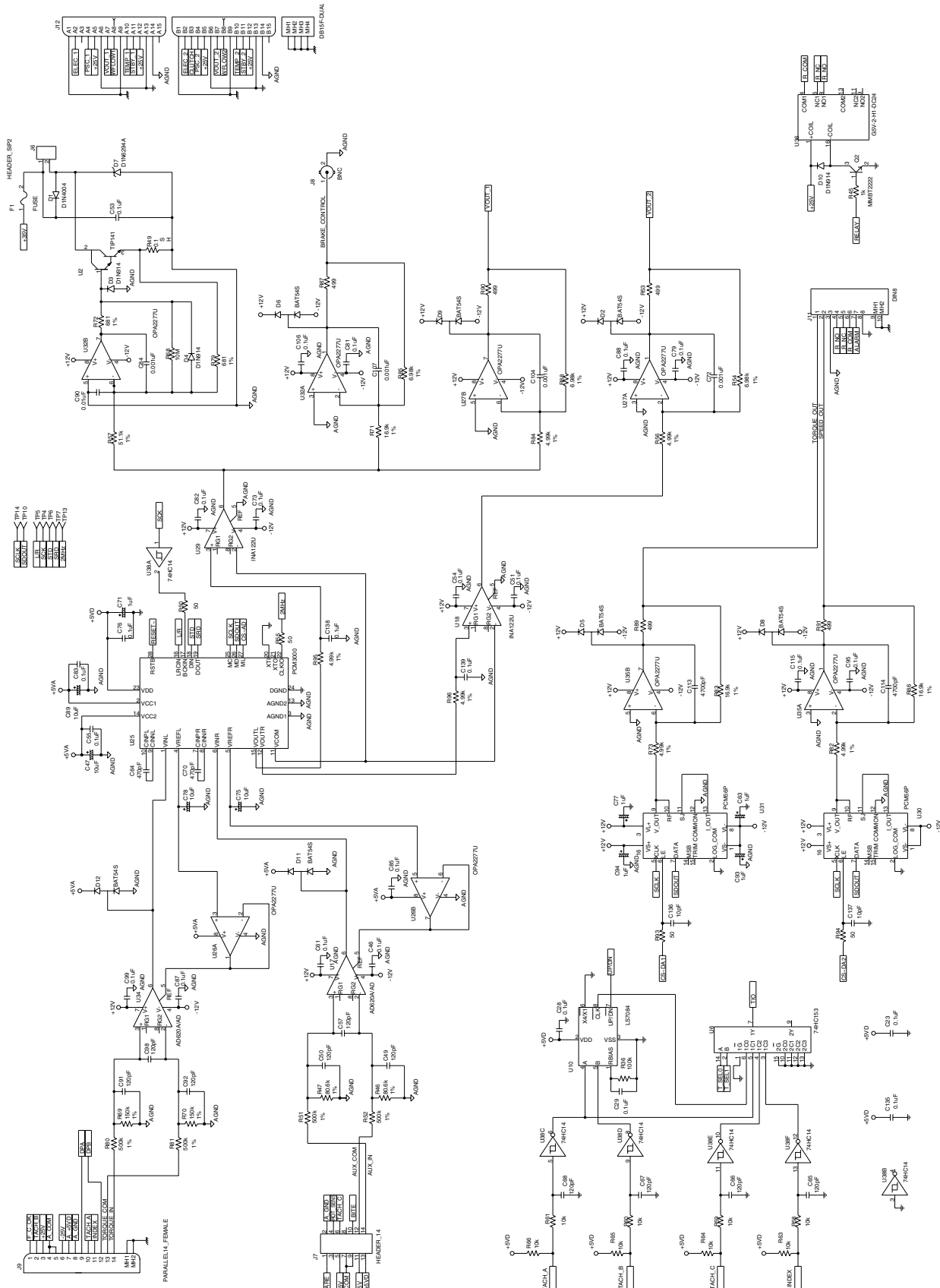

Appendix F: Additional Scale Factor Table

The Additional Scale Factor Table is the same as the M-TEST Defaults file, which contains default values for all parameters used in the testing of Magtrol Dynamometers and Torque Transducers. The M-TEST Defaults file is subject to change as ratings on Magtrol's Motor Test Equipment change but the most recent version of this file can always be accessed from our Web site at www.magtrol.com/support/downloads.htm#mtestdefaults. Simply click the link if you are connected to the Internet or type the web address into your browser.

The file is saved in a tab delimited text format and can be accessed by Microsoft® Excel or LabVIEW™ programs, including M-TEST. If you need this information to configure your DSP6001 but do not have M-TEST 4.0 or 5.0, the text file can be imported into any spreadsheet or database program and the default values can be manually programmed into the DSP6001 via the front panel menu system. Be sure to check the file frequently to make sure you have the most current data. Please feel free to contact our sales department at 1-716-668-5555, if you should have any questions or concerns.

Index

A

Accessory Torque-Speed Output 12,37,80
Additional Scale Factor 42,110
Advanced Configuration 101
Air Flow Alarm 56
Alarm
 Commands 69
 Operation 51
 Priority 52
 Relay 50
Alarms
 Air Flow 56
 Electrical 60
 External 58
 Maximum Speed 53
 Maximum Torque 54
 Power 52
 Temperature 59
Alarm System 50
AUX/TSC2 Connector 13,78
Auxiliary Instrumentation
 Setup 22,28,95
Aux Setup Menu 90

B

Baud Rate 67
Bit Configurations 36
Brake Fuse 12
Bypass Capacitors 107

C

Calibration 76
 Procedure 76
 Schedule 76
Channels
 Dynamometer 61
Command Set 69,101
Communication
 Commands 70
 Parameters 67
Com Setup Menu 91
Configuration 15
Contrast Settings 11
Controls 8
Controls and Buttons 8
Cross Loop Function 35
CTRL OUT 12

D

DAC Output Offset and Gain 78
Data Format 68

Data Sheet 2
Decimal Point Check 81
Derivative 40,43
Digital Filters 38
Dynamic Scale Effect 49
Dynamometer Analog I/O 109
Dynamometer Channel 61
Dynamometer Configuration 18
Dynamometer Configuration Menu 18
Dynamometer DSP 108
Dynamometer Memory 108
Dynamometer Power Bypass Capacitors 107
Dynamometer Setup Menu 93
Dyno Setup Menu 18,92

E

Earth Ground 14
Eddy-Current Dynamometer 41
 Setup 24,26,27,28,29,31,33,95,96,98
Electrical Alarm 60
Encoder
External Alarm 58

F

Features 1
Flowcharts 88,101
Front Panel 8,88
Functions
 Primary 88
 Saving 9
 Secondary 8,89

G

GPIB
 Installation 65
 Interface 14,65
 Primary Address 66

H

Hysteresis Dynamometer 41
 Setup 19,20,22,24,94

I

Inputs 12
 AUX/TSC2 13,78
 Dynamometer/TSC1 13,77
 Dynamometer Analog I/O 109
 Dynamometer Brake 12
 Supply 1 13,79
 Supply 2 14,79
Installation 15

GPIB 65
Integral 40,42

L

LabVIEW Programming Examples 83
Line Voltage 15

M

Maximum Speed Alarm 53
Maximum Torque Alarm 54
MaxPower Setup Menu 92
Max Speed Menu 90
Memory 108
Menus 88
 Alarm Setup 100
 Aux Setup 21,90
 Com Setup 91
 Dynamometer Configuration 18,93
 Dyno Setup 18,92
 Encoder Setup 36,99
 Hysteresis Setup 19
 Main Menu 16
 MaxPower Setup 92
 Max Speed 90
 Power Units 89
 Torque Transducer Setup 21,94
 Torque Units 89
Miscellaneous
 Commands 75
 Configuration 106

O

Open Loop Control 64
Outputs 12
 Accessory Torque-Speed 12,37,80
 CTRL OUT 12
 Dynamometer Analog I/O 109

P

PC Configuration 101
PC Connection 67
PC Control 101
PID Loop 40,41
PID Settings 40,43
 Ramp Down 48
 Speed Control 46
 Torque Control 43
Powder Dynamometer 41
 Setup 24,26,27,28,29,31,33,97,98
Power Alarm 52
Power Bypass Capacitors 107
Power Cord 14
Power Units 62,89
Pre-Test Configuration 102

Programming 68
Proportional Gain 40,42

R

Ramp
 Commands 71
 Configuration 103
Ramp Down
 PID Settings 48
Rear Panel 12
Remote Configuration 101
Remote Control 101
RS-232 Interface 14,66

S

Saving Function 9
Scale Factor 41
 Speed DAC 37
 Torque DAC 37
Schematics 107
Screen Saver 11
Secondary Functions 8
Self-Test 16
Setup
 Auxiliary Instrumentation 22,28,95
 Eddy-Current Dynamometer 24,26,27,28,29,31,33,95,96,98
 Hysteresis Dynamometer 19,20,22,24,27,94
 Independent 29
 Powder Dynamometer 24,26,27,28,29,31,33,95,97,98
 Speed Encoder 36,99
 Tandem 31,33,96,97,98
 Torque/Speed DAC 37
 Torque Transducer 20,35,94
Setup Commands 72
Simple Read 83
Speed
 Commands 74
 Configuration 104
Speed Check 80
Speed Control 63
 PID Settings 46
Speed Correction 41
Speed DAC Scale Factor 37
Speed Encoder
 Setup 36,99
Speed Stabilized 85
Status Display Messages 11
Supply 1 Connector 13,79
Supply 2 Connector 14,79

T

Tandem Setup 31,33,96,97,98
Temperature Alarm 59

- Testing Instrumentation Setup 17
- Timeout 69
- Torque
 - Configuration 105
- Torque Commands 74
- Torque Control 62
 - PID Settings 43
- Torque DAC Scale Factor 37
- Torque Stabilized 84
- Torque Transducer
 - Setup 20,27,35,94
- Torque Transducer Setup 94
- Torque Units 62,89
- Troubleshooting 82
- TSC1 Offset and Gain 77
- TSC2 Offset and Gain 78

V

- Vacuum Fluorescent Display 10

Magtrol Limited Warranty

Magtrol, Inc. warrants its products to be free from defects in material and workmanship under normal use and service for a period of twenty-four (24) months from the date of shipment. Software is warranted to operate in accordance with its programmed instructions on appropriate Magtrol instruments. This warranty extends only to the original purchaser and shall not apply to fuses, computer media, or any other product which, in Magtrol's sole opinion, has been subject to misuse, alteration, abuse or abnormal conditions of operation or shipping.

Magtrol's obligation under this warranty is limited to repair or replacement of a product which is returned to the factory within the warranty period and is determined, upon examination by Magtrol, to be defective. If Magtrol determines that the defect or malfunction has been caused by misuse, alteration, abuse or abnormal conditions of operation or shipping, Magtrol will repair the product and bill the purchaser for the reasonable cost of repair. If the product is not covered by this warranty, Magtrol will, if requested by purchaser, submit an estimate of the repair costs before work is started.

To obtain repair service under this warranty, purchaser must forward the product (transportation prepaid) and a description of the malfunction to the factory. The instrument shall be repaired at the factory and returned to purchaser, transportation prepaid. **MAGTROL ASSUMES NO RISK FOR IN-TRANSIT DAMAGE.**

THE FOREGOING WARRANTY IS PURCHASER'S SOLE AND EXCLUSIVE REMEDY AND IS IN LIEU OF ALL OTHER WARRANTIES, EXPRESSED OR IMPLIED, INCLUDING BUT NOT LIMITED TO ANY IMPLIED WARRANTY OF MERCHANTABILITY, OR FITNESS FOR ANY PARTICULAR PURPOSE OR USE. MAGTROL SHALL NOT BE LIABLE FOR ANY SPECIAL, INDIRECT, INCIDENTAL, OR CONSEQUENTIAL DAMAGES OR LOSS WHETHER IN CONTRACT, TORT, OR OTHERWISE.

CLAIMS

Immediately upon arrival, purchaser shall check the packing container against the enclosed packing list and shall, within thirty (30) days of arrival, give Magtrol notice of shortages or any nonconformity with the terms of the order. If purchaser fails to give notice, the delivery shall be deemed to conform with the terms of the order.

The purchaser assumes all risk of loss or damage to products upon delivery by Magtrol to the carrier. If a product is damaged in transit, **PURCHASER MUST FILE ALL CLAIMS FOR DAMAGE WITH THE CARRIER** to obtain compensation. Upon request by purchaser, Magtrol will submit an estimate of the cost to repair shipment damage.

Service Information

RETURNING MAGTROL EQUIPMENT FOR REPAIR AND/OR CALIBRATION

Before returning equipment to Magtrol for repair and/or calibration, please visit Magtrol's Web site at <http://www.magtrol.com/support/rma.htm> to begin the Return Material Authorization (RMA) process. Depending on where the equipment is located and which unit(s) will be returned, you will be directed to either ship your equipment back to Magtrol, Inc. in the United States or Magtrol SA in Switzerland.

Returning Equipment to Magtrol, Inc. (United States)

When returning equipment to Magtrol, Inc.'s factory in the United States for repair and/or calibration, a completed Return Material Authorization (RMA) form is required.

1. Visit Magtrol's Web site at <http://www.magtrol.com/support/rma.htm> to begin the RMA process.
2. Complete the RMA form online and submit.
3. An RMA number will be issued to you via e-mail. Include this number on all return documentation.
4. Ship your equipment to:
MAGTROL, INC.
70 Gardenville Parkway
Buffalo, NY 14224
Attn: Repair Department
5. After Magtrol's Repair Department receives and analyzes your equipment, a quotation listing all the necessary parts and labor costs, if any, will be faxed or e-mailed to you.
6. After receiving your repair estimate, provide Magtrol with a P.O. number as soon as possible. A purchase order confirming the cost quoted is required before your equipment can be returned.

Returning Equipment to Magtrol SA (Switzerland)

If you are directed to ship your equipment to Switzerland, no RMA form/number is required. Just send your equipment directly to Magtrol SA in Switzerland and follow these shipment instructions:

1. Ship your equipment to:
MAGTROL SA
After Sales Service
Centre technologique Montena
1728 Rossens / Fribourg
Switzerland
VAT No: 485 572
2. Please use our forwarder : TNT • 1-800-558-5555 • Account No 154033
Only ship ECONOMIC way (3 days max. within Europe)
3. Include the following documents with your equipment:
 - Delivery note with Magtrol SA's address (as listed above)
 - Three pro forma invoices with:
 - Your VAT number
 - Description of returned goods
 - Noticed failures
 - Value - for customs purposes only
 - Origin of the goods (in general, Switzerland)
4. A cost estimate for repair will be sent to you as soon as the goods have been analyzed. If the repair charges do not exceed 25% the price of a new unit, the repair or calibration will be completed without requiring prior customer authorization.



Testing, Measurement and Control of Torque-Speed-Power • Load-Force-Weight • Tension • Displacement

www.magtrol.com

MAGTROL INC

70 Gardenville Parkway
Buffalo, New York 14224 USA
Phone: +1 716 668 5555
Fax: +1 716 668 8705
E-mail: magtrol@magtrol.com

MAGTROL SA

Centre technologique Montena
1728 Rossens/Fribourg, Switzerland
Phone: +41 (0)26 407 3000
Fax: +41 (0)26 407 3001
E-mail: magtrol@magtrol.ch

Subsidiaries in:

- Germany
- France
- Great Britain
- China

Worldwide Network
of Sales Agents

Certified ISO 9001 : 2000 by



n° 150887