

THE
11A16
TWO-CHANNEL
CURRENT
AMPLIFIER

Service Reference

WARNING

The following servicing instructions are for use by qualified service personnel only. To avoid personal injury, do not perform any servicing unless you are qualified to do so. Refer to the Safety Summary prior to performing any service.

*Please check for CHANGE INFORMATION
at the rear of this manual.*

Instrument Serial Numbers

Each instrument manufactured by Tektronix has a serial number on a panel insert or tag, or stamped on the chassis. The first letter in the serial number designates the country of manufacture. The last five digits of the serial number are assigned sequentially and are unique to each instrument. Those manufactured in the United States have six unique digits. The country of manufacture is identified as follows:

B010000	Tektronix, Inc., Beaverton, Oregon, USA
E200000	Tektronix United Kingdom, Ltd., London
J300000	Sony/Tektronix, Japan
H700000	Tektronix Holland, NV, Heerenveen, The Netherlands

Instruments manufactured for Tektronix by external vendors outside the United States are assigned a two digit alpha code to identify the country of manufacture (e.g., JP for Japan, HK for Hong Kong, etc.).

Tektronix, Inc., P.O. Box 500, Beaverton, OR 97077

Printed in U.S.A.

Copyright © Tektronix, Inc., 1991. All rights reserved. Tektronix products are covered by U.S. and foreign patents, issued and pending. The following are registered trademarks: TEKTRONIX, TEK, TEKPROBE, SCOPEMOBILE and



Contents

General Information	
Safety Summary	1-2
Installing and Removing the 11A16	1-4
Memory Backup Power for the 11A16	1-5
Operating Environment	1-5
Packaging for Shipment	1-5
Instrument Options	1-6
Checks and Adjustments	
Test Equipment	2-3
Using These Procedures	2-5
Conventions in this Manual	2-5
Initial Mainframe Settings	2-5
Menu Selections and Measurement Techniques	2-5
A6303 Current Probe Adjustment	2-6
Procedure 1 Initial Setup	2-10
Procedure 2 Enhanced Accuracy	2-11
Procedure 3 High Frequency Response	2-13
Procedure 4 Overload	2-18
Procedure 5 Input Resistance	2-20
Procedure 6 DC Balance	2-21
Procedure 7 Vertical Accuracy	2-23
Procedure 8 Bandwidth Limit	2-25
Procedure 9 AC Coupling	2-27
Procedure 10 ΔV DC Accuracy	2-30
Procedure 11 DC Offset Accuracy	2-34
Procedure 12 Degauss Ability	2-38
Procedure 13 Probe Calibration	2-40
Maintenance	
Preventive Maintenance	3-1
11A16 Side Shield Removal	3-1
Cleaning	3-1
Visual Inspection	3-2
Diagnostic Troubleshooting	3-2
Kernel Tests	3-2
Self Tests	3-4
Extended Diagnostics	3-4
Enhanced Accuracy Errors	3-4
Error Index Codes	3-5
Other Messages	3-9
Calibrating a New Configuration	3-9
Restoring Calibration Data	3-9
Conventional Troubleshooting	3-10
Front Panel Connector Troubleshooting	3-10
Fuse Troubleshooting	3-10
Darlington NPN or PNP Power Transistor Troubleshooting	3-10
Panel Connector Troubleshooting	3-10

Relay Troubleshooting	3-10
Jumper Troubleshooting	3-10
Field Replaceable Unit (FRU) Guide	3-11
Abbreviations of FRU Names	3-11
Abbreviations of Component Names	3-11
Ordering Parts	3-12
Static-Sensitive Device Classification	3-12
Removing/Replacing FRUs	3-13
Removing/Replacing an Attenuator board	3-16
Removing/Replacing the Connector Assembly	3-17
Removing/Replacing a Darlington Power Transistor	3-20
Removing/Replacing a Sample and Hold board	3-20
Removing/Replacing the Front Panel	3-21
Removing/Replacing a Front Panel board	3-24
Removing/Replacing a Fuse	3-24
Removing/Replacing the IC Heatsink Bracket	3-24
Removing/Replacing the Hypcon Assembly	3-25
Removing/Replacing the Main board	3-28
Removing/Replacing Multi-Pin Connectors	3-31
Removing/Replacing a Pin Jumper	3-31
Removing/Replacing a Relay	3-31
Removing/Replacing a DIP FRU IC	3-32
Removing/Replacing a "Slam-Pack" IC	3-33
Programming the Unit Identification	3-35
Theory of Operation	
Typical Signal Processing Cycle	4-1
Detailed Block Diagram Descriptions	4-2
Analog Circuitry	4-2
Digital Circuitry	4-4
Front Panel Block	4-4
Current Probe	4-4
Replaceable Parts	
Parts Ordering Information	5-1
Using the Replaceable Parts List	5-2
Change Information	

List of Illustrations

Figure 1-1	Installing and Removing the 11A16	1-4
Figure 2-1	Location of Adjustments on the A6303 Current Probe	2-7
Figure 2-2	Measurement of Plug-in Contribution to Aberrations	2-14
Figure 2-3	Waveform with DC Coupling (Top) and AC Coupling (Bottom)	2-28
Figure 3-1	Sample LED Fault Code Timing Diagram	3-3
Figure 3-2	FRU and FRU IC Locator	3-14
Figure 3-3	Removing/Replacing an Attenuator	3-16
Figure 3-4	Proper Orientation of the Current Probe Connector	3-18
Figure 3-5	Installation Wiring for Current Probe Connector	3-19
Figure 3-6	Removing/Replacing the Front Panel Retainer Screws	3-22
Figure 3-7	Removing/Replacing the Probe Connectors, Front Panel, and the Front Panel Boards	3-23
Figure 3-8	Removing/Replacing the Heatsink Bracket	3-25
Figure 3-9	Removing/Replacing the Hypcon Assembly	3-26
Figure 3-10	Removing/Replacing the Main board	3-29
Figure 3-11	Torx Screw and Nut Block Orientation	3-29
Figure 3-12	Multi-Pin Connector Orientation	3-31
Figure 3-13	IC Insertion-Extraction Pliers	3-33
Figure 3-14	Semiconductor Indexing Diagram	3-34
Figure 4-1	11A16 System Functional Block Diagram	4-1
Figure 4-2	11A16 Detailed Block Diagram (One Analog Channel)	4-2
Figure 5-1	Exploded View of the 11A16 Two Channel Current Amplifier	5-6

List of Tables

Table 2-1	Measurement Limits, Specifications, Adjustments, and Functional Test	2-1
Table 2-2	Test Equipment	2-3
Table 2-3	Deflection Factors and Associated Test Conditions	2-15
Table 2-4	11A16 DC Balance Error Limits	2-22
Table 2-5	11A16 DC Accuracy Error Limits	2-33
Table 2-6	11A16 DC Offset Accuracy	2-37
Table 3-1	11A16 Kernel Error Index Codes	3-5
Table 3-2	Self-Tests/Extended Diagnostics Error Index Codes	3-6
Table 3-3	Sample and Hold Board Failure Codes	3-7
Table 3-4	Enhanced Accuracy Error Index Codes	3-8
Table 3-5	Board FRUs	3-11
Table 3-6	Component/Module FRUs	3-11
Table 3-7	Relative Susceptibility to Damage from Static Discharge ...	3-13
Table 3-8	FRU Removal/Replacement Procedure Cross Reference ...	3-15
Table 5-1	Board FRUs	5-2

General Information

This reference provides service information and test procedures for the 11A16 Two-Channel Current Amplifier. It contains information necessary for qualified service personnel to check, maintain, and troubleshoot the 11A16.

Checking the 11A16 involves performing a sequence of Check and Adjustment procedures. These procedures verify that the 11A16 is operating correctly.

The majority of Troubleshooting is based upon internal diagnostics that the mainframe and 11A16 perform automatically. Some visual and mechanical troubleshooting may be necessary. Both diagnostic techniques isolate problems to the field replaceable unit (FRU) level. Once the faulty FRU is identified, you can use the Corrective Maintenance section to remove and replace the faulty FRU.

The 11A16 is a two-channel, medium-bandwidth, current amplifier that plugs into any of the 11000 or DSA 600 Series mainframes that use amplifiers. Commands from the mainframe control all 11A16 functions except probe degauss. For example:

- Any combination of the two input channels can be provided to the host mainframe.
- Signals can be independently inverted and summed.
- Channel bandwidth limiting can be switched between 20 and 50 MHz.

The front panel of the 11A16 has two buttons and an LED indicator for each input channel. Other controls and status indicators are located on the mainframe. Each channel has a 12-pin input connector. When a probe is connected to the input, the 11A16 detects the probe-encoding information, to select the appropriate scaling.

This reference contains the following sections:

- **General Information**—describes information that you should know about the 11A16 before you service it, such as safety information, installation and removal, available options, and packaging suggestions.
- **Checks and Adjustments**—provides you with procedures to examine the measurement limits and electrical specifications of the 11A16.
- **Maintenance**—contains information necessary to do preventive maintenance, remove/replace field replaceable units (FRUs), and diagnose faulty FRUs.
- **Theory of Operation**—describes the general operation and signal path of the 11A16.
- **Replaceable Parts**—provides you with a complete list of replaceable electrical and mechanical parts found on the 11A16.

Safety Summary

This general safety information is directed to operators and service personnel. Specific warnings and cautions will be found throughout the manual, but may not appear in this summary.

Terms in Manuals

CAUTION statements in manuals identify conditions or actions that could damage the equipment or other property.

WARNING statements in manuals identify conditions or actions that could result in personal injury or loss of life.

Terms on Equipment

CAUTION warns you of possible hazards to the equipment or yourself though you are not exposed as you read the marking.

DANGER warns of a personal injury hazard as you read the marking.

Symbols in Manuals



Static Sensitive Devices

Symbols on Equipment



DANGER
High Voltage



Protective
ground (earth)
terminal



ATTENTION
Refer to
manual

Power Source

This 11A16 is intended to operate in a mainframe connected to a power source that will not apply more than 250 V rms between the supply conductors or between either a supply conductor and ground. A protective ground connection, through the grounding conductor in the mainframe power cord, is essential for safe system operation.

Grounding the 11A16

The 11A16 is grounded through the grounding conductor of the mainframe power cord. To avoid electric shock, plug the mainframe power cord into a properly wired receptacle before installing the 11A16. A protective ground connection, through the grounding conductor in the mainframe power cord, is essential for safe operation.

Danger Arising from Loss of Ground

Upon loss of the protective-ground connection, all accessible conductive parts (including knobs and controls that may appear to be insulators), can render an electrical shock.

Do Not Operate in Explosive Atmospheres

To avoid explosion, do not operate this product in an atmosphere of explosive gasses.

Do Not Service Alone

Do not perform internal service or adjustment of this product unless another person capable of rendering first aid and resuscitation is present.

Use Care When Servicing with Power On

Dangerous voltages exist at several points in this product. To avoid personal injury, do not touch exposed connections or components while the power is on.

Disconnect the power before removing protective panels, or replacing components.

Installing and Removing the 11A16



Install the 11A16 in an 11000 or DSA 600 Series mainframe as follows:

- Step 1: Set the mainframe ON/STANDBY switch to STANDBY.

If the green indicator light remains on when the STANDBY position is selected, then the switch was internally disabled when the power supply was serviced. To enable the ON/STANDBY switch, refer to the Corrective Maintenance section of the Service Reference manual for your mainframe.

- Step 2: Align the grooves in the top and bottom of the 11A16 with the guides in the mainframe plug-in compartment.
- Step 3: Slide the 11A16 into the compartment until the front panel of the 11A16 is flush with the front panel of the mainframe.

Remove the 11A16 from a 11000 or DSA 600 Series Mainframe as follows:

- Step 1: Set the mainframe ON/STANDBY switch to STANDBY.
- Step 2: Pull the release latch (see Fig. 1-1) to disengage the 11A16 from the mainframe.
- Step 3: Slide the 11A16 straight out of the plug-in compartment.

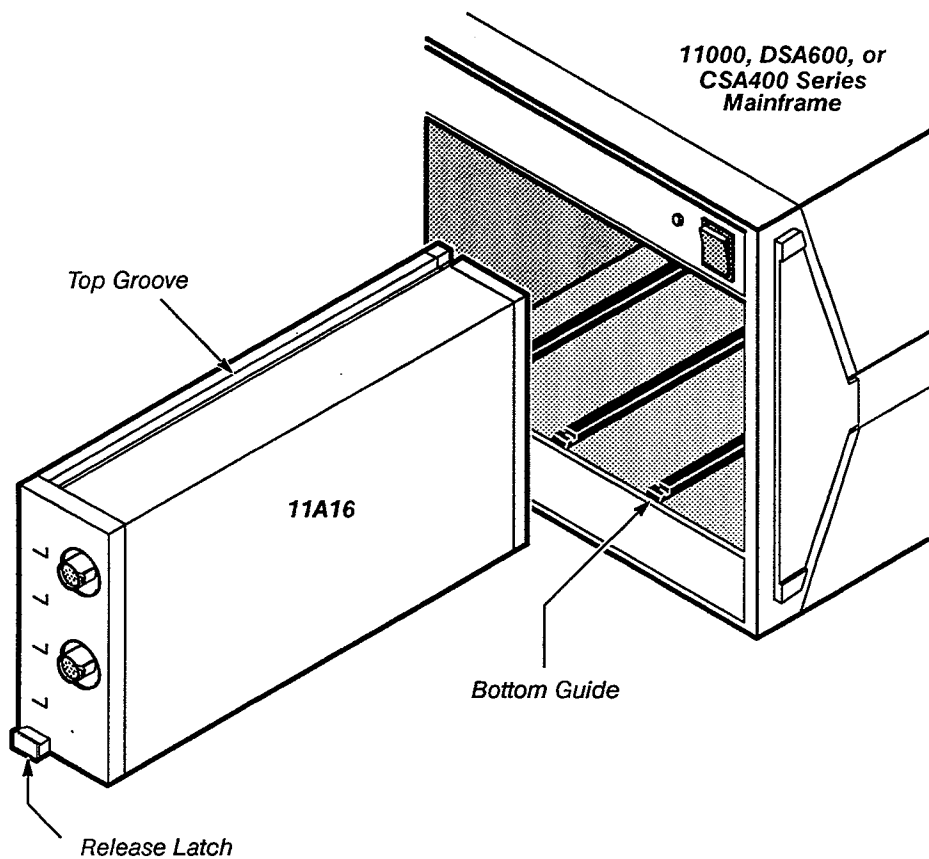

Figure 1-1 — Installing and Removing the 11A16

Memory Backup Power for the 11A16

The nonvolatile RAM (NVRAM) within the 11A16 allows the data in memory to be retained when the 11A16 is powered-down and removed. The NVRAM stores system-configuration data such as the 11A16, mainframe, and probe identification numbers as well as the calibration constants. The data that the NVRAM stores enable the 11A16 to resume Enhanced Accuracy performance (see your mainframe User Reference for Enhanced Accuracy operation) from a powered-off condition, without performing a full calibration (Enhanced Accuracy) operation. The rated lifetime of the NVRAM internal power source is ten years. If the 11A16 habitually loses Enhanced Accuracy status without a system configuration change (that is, the 11A16 remains plugged into the same slot in the same mainframe), then you may need to replace the NVRAM.

Operating Environment

To ensure proper functioning and extended operation of the 11A16, operate and store the 11A16 within the following environments:

- Operate the 11A16 in a mainframe where the ambient air temperature is between 0° and +50°C.
- Store the 11A16 in ambient temperatures from -40° to +75°C.
- After storing the 11A16 at temperatures outside the operating limits, allow the 11A16 to reach the safe operating temperature before applying power.

Enhanced system accuracy is available after a 20-minute warmup period. If the mainframe is in the Enhanced Accuracy state and the internal temperature of the mainframe changes $\pm 5^{\circ}\text{C}$, the mainframe reverts to normal accuracy.

Packaging for Shipment

If you are shipping the 11A16 to your local Tektronix service center for repair, attach a tag to the instrument with the following information:

- Name and address of the 11A16 owner.
- Name of a person at your firm who can be contacted about the 11A16.
- 11A16 type and serial number.
- Description of the service required.

Save and reuse the original carton and packaging when shipping the 11A16 by commercial transportation. Be sure to package and ship the 11A16 and mainframe separately. If the original package is not available or is not reusable, package the 11A16 as follows:

1. Obtain a corrugated cardboard carton with dimensions at least six inches (15 cm) greater than the 11A16 dimensions. Use a carton with a bursting test strength of at least 200 pounds per square-inch.
2. Fully wrap the 11A16 with anti-static sheeting to protect its finish.
3. Tightly pack 3 inches of dunnage or urethane foam between the carton and the 11A16 to cushion it.
4. Seal the carton with shipping tape or with industrial staples.
5. Mark the address of the Tektronix service center and your return address on the carton.

Instrument Options

Your 11A16 may be equipped with one or more options. A brief description of the available options follow. For further information and prices, see your *Tektronix Product Catalog* or contact your local Tektronix service center.

Option 20—adds two A6302 Current probes.

Checks and Adjustments

This section contains procedures that allow you to examine measurement limits and electrical specifications of the 11A16 Two-Channel Current Amplifier. Procedures 1-13 (see Table 2-1) are intended to return the 11A16 to proper operation following repair or to serve as part of a routine maintenance program.

To ensure accurate operation of the 11A16, check the electrical adjustment after each 2,000 hours of operation or every 24 months if you use the 11A16 infrequently. Refer to the *11A16 User Reference* for more information about specifications and amplifier operation. If an A6303 Current probe is to be used in the following procedures, you should first calibrate it using the procedure on page 2-6.

To verify that the instrument is functioning, perform the procedures which have a "✓" indication in the Functional Test column of Table 2-1. If you wish to verify the specifications of the instrument, perform all procedures.

Table 2-1 – Measurement Limits, Specifications, Adjustments, and Functional Test

Procedure and Description	Measurement Limits (<i>Examine</i>)	Specifications (<i>Check</i>)	Adjustments (<i>Adjust</i>)	Functional Test
Procedure 1 Initial Setup	none	none	none	✓
Procedure 2 Enhanced Accuracy	successful execution	none	none	✓
Procedure 3 High Frequency Response				✓
Amplifier Step Response	aberrations $\leq 5\%$ peak and 8% p-p	none	none	
Amplifier Bandwidth	none	amplitude at 120 MHz $\geq 78\%$ of 500 kHz reference	none	
Procedure 4 Overload	none	coupling changes to off	none	✓
Procedure 5 Input Resistance	none	50 Ω $\pm 2\%$	none	✓
Procedure 6 DC Balance	none	refer to Table 2-4	none	

Table 2-1 – Measurement Limits, Specifications, Adjustments, and Functional Test (Cont.)

Procedure and Description	Measurement Limits (Examine)	Specifications (Check)	Adjustments (Adjust)	Functional Test
Procedure 7 Vertical Accuracy				✓
Gain	none	5 V ±50 mV for the 11400-Series (DSA 600)	none	
Procedure 8 Bandwidth Limit	none	at 100 MHz limit: 2.45 ns < rise time < 4.55 ns at 20 MHz limit: 12.3 ns < rise time < 22.7 ns	none	✓
Procedure 9 AC Coupling	none	bottom of square wave at center graticule line then waveform vertically centered on screen	none	✓
Procedure 10 ΔV DC Accuracy	none	2 mV – 2 V/div ±0.53%; 1 mV ±0.78%	none	
Procedure 11 DC Offset Accuracy	none	refer to Table 2-6	none	
Procedure 12 Degauss Ability	none	signal trace zero	none	✓
Procedure 13 Probe Calibration	none	successful auto-calibration		✓

Test Equipment

Table 2-2, Test Equipment, lists recommended test equipment for use when checking and/or adjusting the amplifier. The Functional Test column of Table 2-2 indicates, with a check mark (✓), the test equipment that is recommended if you are performing a functional test only. Check and Adjustment steps are based on the test equipment examples given, but other equipment with similar specifications may be substituted. If you use different equipment, this may alter test results, setup information, and required connectors and adapters.

Table 2-2 – Test Equipment

Description	Minimum Specification	Examples of Recommended Test Equipment	Functional Test
11400 or DSA 600 Series Mainframe that accepts amplifiers	Tektronix mainframe that accommodates amplifiers	TEKTRONIX 11401 Digitizing Oscilloscope 11402 Digitizing Oscilloscope 11403 Digitizing Oscilloscope 11403A Digitizing Oscilloscope DSA 600 Series Digitizing Signal Analyzers CSA 404 Communications Signal Analyzer	✓
Current Probe	A6302 ¹ or A6303 ²	Tektronix A6302 ¹ with serial number above B050000 or A6303 ² probes	✓
Leveled Sine Wave Generator	260 kHz to 250 MHz, Leveled variable amplitude, 50 kHz ref	TEKTRONIX SG 503 Leveled Sine Wave Generator with a TM 500-Series Power Module	✓
Power Supply	Continuously variable from 0–40 V; current limit, adjustable from 0–400 mA; 20 V at 400 mA with over current protection	TEKTRONIX PS 503A Dual Power Supply with a TM 500-Series Power Module	✓
DC Voltage Calibrator	Output, 0–4 V; accuracy and short term stability >0.05%	Fluke 5101B, Fluke 343A (portable) Data Precision 8200	
Digital Multimeter (with test leads)	Accuracy ≤0.01%	Fluke 8842A Digital Multimeter	✓
Calibration Generator	Period, 10 ms to 1 μs; Amplitude, fast rise mode (≤1 ns) 1 V, Standard mode 200 μVp-p to 5 Vp-p into 50 Ω; Square wave output, 0.25% accuracy, 1-2-5 amplifier selection.	TEKTRONIX PG 506A Calibration Generator with a TM 500-Series Power Module	✓
Voltage Adapter	BNC to 12-pin current probe connector	Tektronix Part 015-0598-00 (11A16 standard accessory)	✓

¹A6302 Current probes with Serial Numbers greater than B050000 have nickel-plated connectors which provide better shield grounding and superior immunity to electromagnetic noise.

²A6303 Current probes should be calibrated with the procedure on page 2-6 before use in the verification procedures.

Table 2-2 – Test Equipment (Cont.)

Description	Minimum Specification	Examples of Recommended Test Equipment	Functional Test
Current Loop Adapter	Probe calibration fixture (0 Ω) for use with 11400 and DSA600 Series Oscilloscopes	Tektronix Part 015-0601-00 (11A16 standard accessory)	✓
Coaxial Cable, 36-inch (2 required)	50 Ω , 36-inch male BNC connectors	Tektronix Part 012-0482-00	
Coaxial Cable, 42-inch (2 required)	50 Ω , 42-inch male BNC connectors	Tektronix Part 012-0057-01	✓
Attenuator, 2.5X	Impedance: 50 Ω , one male and one female BNC connector	Tektronix Part 011-0076-02	✓
Attenuator, 5X	Impedance: 50 Ω , one male and one female BNC connector	Tektronix Part 011-0060-02	✓
Attenuator, 10X	Impedance: 50 Ω , one male and one female BNC connector	Tektronix Part 011-0059-02	✓
Adapter, BNC-to-Banana (2 required)	BNC Female-to-Dual Banana connector	Tektronix Part 103-0090-00	✓
Adapter, T	BNC, T: Two female and one male BNC connector	Tektronix Part 103-0030-00	✓
Adapter, BNC Barrel	BNC, Two female connectors	Tektronix Part 103-0028-00	✓
Torx Screwdriver and Tips	#6 tip #8 tip #10 tip #10 tip narrow shank #15 tip	Tektronix Part 003-1415-00 Tektronix Part 003-0964-00 Tektronix Part 003-0814-00 Tektronix Part 003-0815-00 Tektronix Part 003-0966-00	
Integrated Circuit Extracting Tool	IC insertion-extraction pliers, 28-pin type	General Tool P/N U505BG or equivalent	

Using These Procedures

The first-time user should familiarize themselves with the information below prior to performing the procedures that follow.

At the beginning of each Check and Adjustment procedure, a short narrative describes the purpose of the procedure. The next section, labeled *Measurement Limit*, gives the proper range for a specification. A *Specification* section gives the result a procedure should produce. Then a *Setup to...* section provides a figure that shows test equipment setup and connection. The final section labeled *Steps Necessary To Check...* lists the steps required to check the 11A16 specification.

Conventions in this Manual

In these procedures, the following conventions are used:

- CAPITAL letters within the body of text identify front panel controls, indicators, and connectors (for example, MEASURE) on the mainframe and amplifier.
- **Bold** letters identify menu labels, display messages, and commands selectable from the mainframe touch panel.
- Initial Capital letters identify connectors, controls, and indicators (for example, Position) on associated test equipment. Initial Capital letters also identify adjustments inside the amplifier (for example Vert Pos).
- In some steps, the first word is italicized to identify a step that contains a performance verification and/or an adjustment instruction. For example, if *Check* is the first word in the title of a step, an electrical specification is checked. If *Adjust* appears in the title, the step involves an electrical adjustment. If *Examine* is the first word in the title, the step involves measurement limits that are used as calibration guides. These limits are not to be interpreted as electrical specifications.

Initial Mainframe Settings

At the beginning of most procedures, you are instructed to **Initialize** the mainframe as part of the setup. The **Initialize** feature, available through the UTILITY menu, presets all mainframe and plug-in unit controls and functions to known values. Initializing the instruments at the beginning of a step eliminates the possibility of settings from previous steps causing erroneous or confusing results. For more information on initialization, refer to your mainframe *User Reference* manual.

Menu Selections and Measurement Techniques

Details on measurement techniques and instructions for making menu selections are generally not included in this procedure. Comprehensive descriptions of menus and instrument features are located in your mainframe *User Reference* manual.

A6303 Current Probe Adjustment

This procedure adjusts the A6303 for optimum operation in an 11A16 Amplifier. You should adjust an A6303 if it will be used in the following verification procedures. This procedure assumes a fully calibrated 11A16 is installed in the Right plug-in compartment of a 11400 or DSA 600 Series mainframe. The equipment required and its connection are shown in the setup illustration below.

Setup for A6303 Current Probe Adjustment

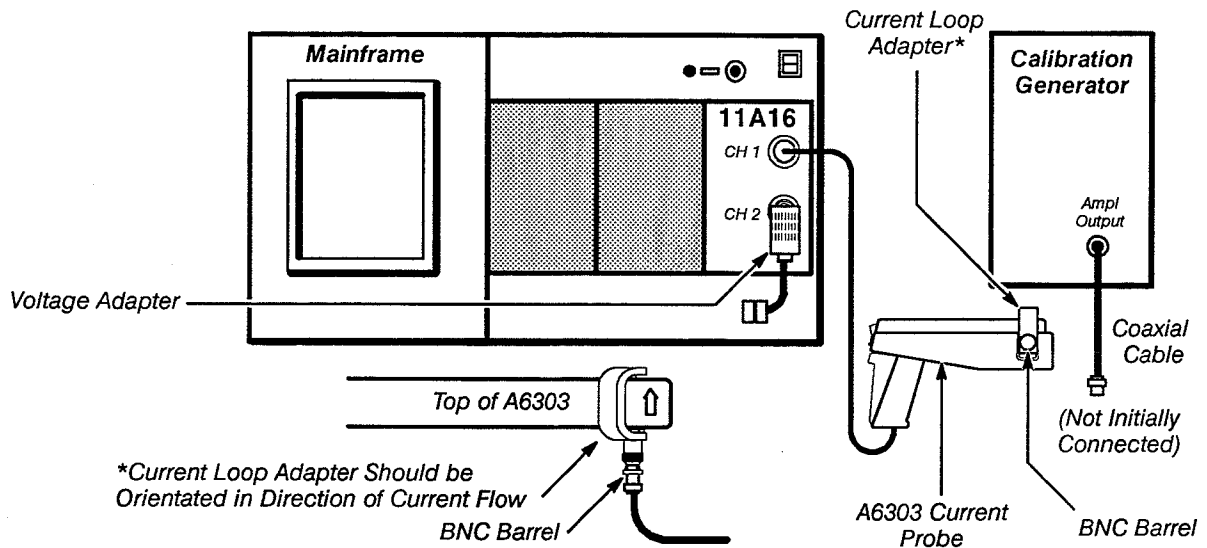

CAUTION

Use the 0 Ω Current Loop Adapter with the 11A16 Amplifier only during probe calibration. If the adapter is connected to the mainframe during power-up or Enhanced Accuracy calibration, the instrument calibration can be corrupted.

The adjustment procedure has three parts: offset adjustment, transient response adjustment, and verification.

Procedure to Adjust Offset

- Step 1: Power up the oscilloscope mainframe, 11A16, A6303 probe and test equipment, and let them warm up for at least 10 minutes.
- Step 2: Set the Calibration Generator Pulse Amplitude to Min (minimum).
- Step 3: Press the display CH 1 button on the 11A16 to enable the channel.
- Step 4: Set the **Vert Size** to 100 mA/div.
- Step 5: Set the vertical **Coupling** to **Off**.
- Step 6: Adjust the **Vert Offset** to position the trace at the graticule center.
- Step 7: Set **Coupling** back to **DC**.

- Step 8: Remove the current probe plug that covers R45. See Figure 2-1.
- Step 9: Now degauss the probe by pressing the CH 1 DEGAUSS button.
- Step 10: Select **Extended Diagnostics** from the Utility major menu.
- Step 11: Select Right 11A16 Plug-in Subsystem or Block, the **CH1 CAL B** Area, and the **AUTO BAL** Routine.
- Step 12: Select **Run** and record the value from the **ACTUAL** column (+ 1000 to -1000 milliunits).
- Step 13: Exit the **Extended Diagnostics** menu.
- Step 14: Adjust R45 based on the value recorded in Step 12 as follows:
 - If the recorded value (X) is negative, adjust R45 to bring the trace down (Xmilli-units/2) mA.
 - If the recorded value (X) is positive, adjust R45 to bring the trace up (Xmilli-units/2) mA.
- Step 15: Degauss the probe again by pressing the CH 1 DEGAUSS button.
- Step 16: Repeat Steps 10 through 14 until the value obtained in the diagnostic test (Step 12) is less than 100 milliunits.
- Step 17: Replace the plug over R45. Proceed to the Transient Response adjustment.

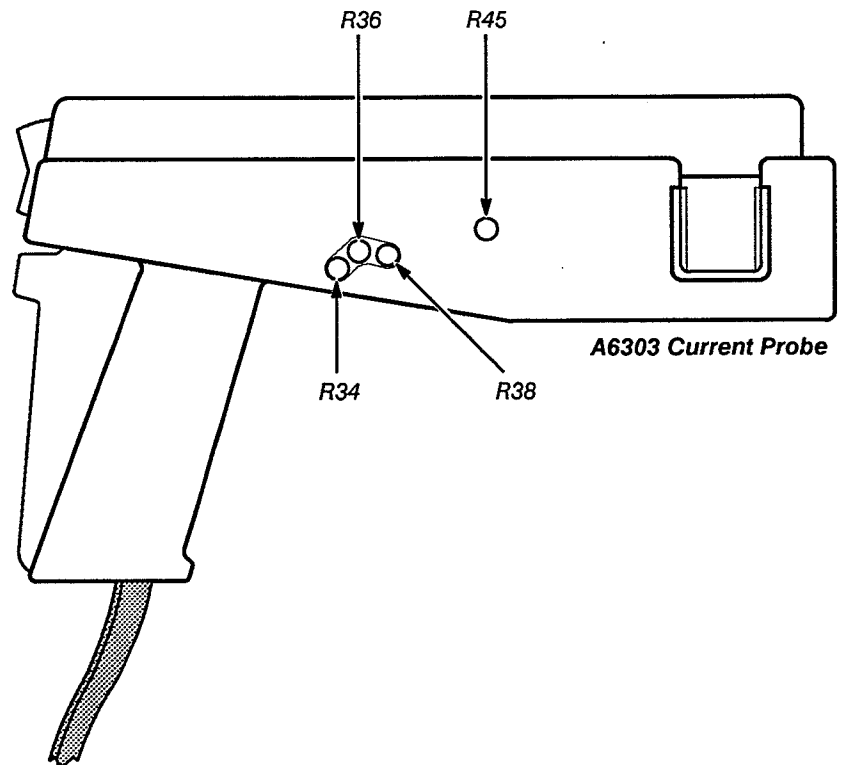

Figure 2-1 – Location of Adjustments on the A6303 Current Probe

Procedure to Adjust Transient Response

- Step 18: Connect the coaxial cable from the Calibration Generator to the CH 2 input through the Voltage Adapter. Leave the current probe connected to CH 1. Press the display CH 2 button on the 11A16.
- Step 19: Set CH 2 **Vert Size** to 1 V/div, **Main Size** to 2 ms/div, and **Coupling** to DC.
- Step 20: Set the Calibration Generator Period to 0.1 ms and the Pulse Amplitude to 5 divisions (5 V p-p).
- Step 21: Press the display CH 2 button on the 11A16 to disable the channel.
- Step 22: Now degauss the probe by pressing the CH 1 DEGAUSS button.
- Step 23: Move the CH 2 input end of the coaxial cable to the Current Loop Adapter which should already be locked in the jaws of the A6303 probe.
- Step 24: Set the CH 1 **Vert Size** to 25 mA/div and bandwidth limit to 15 MHz. If desired, waveform **Averaging** may be enabled to reduce the displayed noise. (Select **Acquire Desc** in the Waveform major menu, and then **Average N** and **Set AvgN** in the **Acquire Description** pop-up menu. Set the **Average N** knob for 8.)
- Step 25: Set the Calibration Generator Period to 10 ms.
- Step 26: Remove the A6303 access plugs for adjustments R34, R36, and R38. Refer to Figure 2-1.
- Step 27: Adjust R38 for maximum flatness on the displayed signal.
- Step 28: Set the Calibration Generator Period to 0.1 ms.
- Step 29: Set **Main Size** to 10 μ s/div and adjust R34 for optimum transient response.
- Step 30: Set **Main Size** to 1 μ s/div and adjust R36 for optimum transient response.

The adjustments R34, R36, and R38 interact and may require readjustment for optimum transient response with the proper gain.

- Step 31: Repeat Steps 25 through 30 to optimize the transient response.

Procedure to Verify Probe Gain

To verify the adjustments, you will run automated probe calibration by following Procedure 13 in the Checks and Adjustments section.

- Step 32: Calibrate channel **R1**, the channel to which the current probe is connected, by running Steps 1 through 8 of Procedure 13, *Probe Calibration*.
- Step 33: Examine that the probe calibration portion passes. Note that the deskew portion will probably not pass due to the long signal delay time through the A6303 probe. If probe gain calibration passes the probe gain is satisfactory. If probe gain calibration failed, perform the following steps.

-
- Step 34: Examine the probe gain value with Diagnostics by selecting **Extended Diagnostic** from the Utility major menu.
 - Step 35: Select the **Right** Subsystem, the 11A16 Block, the **CH1 CAL B** Area and the **Probe Gain** Routine.
 - Step 36: Select **Run** and record the value shown in the **ACTUAL** column. The **ACTUAL** value should be between MIN and MAX (-15% to -5%). Values of -10% to -12% are typical.
 - Step 37: If the **ACTUAL Probe Gain** value is within the acceptable range, and probe gain calibration failed in Step 32, then the 11A16 should be examined by a Tektronix service center.

If the **ACTUAL Probe Gain** value is *less than* -15%, adjust R38 to increase the signal amplitude slightly and compromise step flatness. Now optimize transient response by performing Steps 18 through 30, while skipping Step R27. *DO NOT* readjust R38 in Step 27, as you have just set it to meet probe gain requirements.

- Step 38: Ensure that Probe Gain is now correct by repeating the gain check in Steps 34 through 36.

Procedure 1 Initial Setup

This procedure shows the setup and lists the steps necessary to configure the mainframe and 11A16. Its purpose is to warm the instruments and test equipment to the proper operating temperature. The Checks and Adjustments procedures should be performed within the ambient temperature range of +18° and +28°C, to ensure proper mainframe and 11A16 operation.

Specification

Power on and warm test equipment.



To avoid equipment damage, set the mainframe ON/STANDBY switch to STANDBY before installing or removing plug-ins.

Turning the mainframe power off during probe calibration, self-calibration, Extended Diagnostics, or other intense system activity may result in some internal data being corrupted. If corruption occurs, refer to Restoring Calibration Data in Section 3.

Setup for Initial Setup

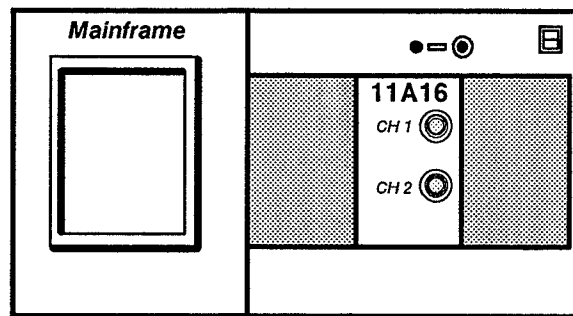

Steps Necessary for Initial Setup

- Step 1: Power on the following test equipment.
 - Power supply
 - Calibration generator
 - Leveled sine wave generator
 - Digital multimeter
- Step 2: With the ON/STANDBY switch set to STANDBY, connect the mainframe to a suitable power source.
- Step 3: Install the 11A16 in the Center plug-in compartment
- Step 4: Set the front panel ON/STANDBY switch to ON.
- Step 5: Allow all equipment to warm up for 20 minutes before continuing.

Procedure 2 Enhanced Accuracy

This procedure describes the setup and lists the steps necessary to check the Enhanced Accuracy state of the mainframe. Its purpose is to verify that the Enhanced Accuracy state can be achieved by the mainframe and 11A16. When the mainframe and 11A16 achieve Enhanced Accuracy, the mainframe will display the symbol (EA). The mainframe stores both the time of calibration and ambient temperature for use in maintaining the Enhanced Accuracy state.

For more information about the Enhanced Accuracy state, see Enhanced Measurement Accuracy Indicator in your mainframe *User Reference* manual.

Specification

When invoked, the Enhanced Accuracy self-calibration executes successfully.

Setup to Check Enhanced Accuracy

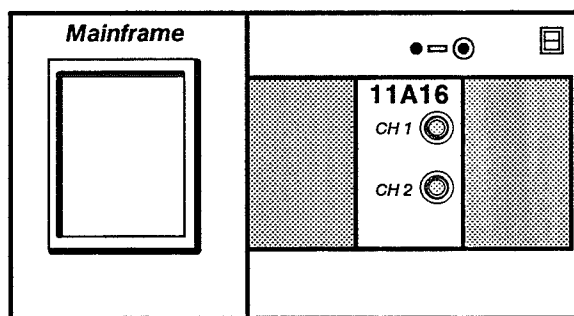

Steps Necessary to Check Enhanced Accuracy

- Step 1: **Initialize** the mainframe settings from the UTILITY major menu.
 - Center Plug-in no setting changes
 - Mainframe no setting changes
- Step 2: Twenty minutes after power-on, the mainframe must recalibrate itself to achieve the Enhanced Accuracy state. Press the ENHANCED ACCURACY button. A prompt then appears on the display. Press the ENHANCED ACCURACY button again. Enhanced Accuracy is achieved after several minutes.

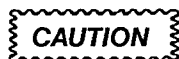

Turning the mainframe power off during Enhanced Accuracy testing may result in losing some of the non-volatile RAM data. This could cause diagnostic errors at the next power-up, and cause the mainframe to operate unpredictably. If this event occurs, refer to Restoring Calibration Data in your mainframe Service Reference manual.

- Step 3: *Examine* the display for the message, **Enhanced Accuracy in Progress** appears. This indicates that the mainframe is performing self-calibration to achieve Enhanced Accuracy.

- Step 4: *Examine* the display for an Enhanced Accuracy complete message indicating that the Enhanced Accuracy state has been achieved. The **EA** indicator appears on the left portion of the display when Enhanced Accuracy is active.

Procedure 3 High Frequency Response

This procedure shows the setup and lists the steps necessary to check the 11A16 high frequency response. The procedure verifies that the aberrations are not excessive and that the bandwidth with the Voltage Adapter (a standard accessory) is adequate. The procedure has two parts: Examine Amplifier Step Response and Check Amplifier Bandwidth.

To obtain lower deflection factors, attenuators are used to reduce the amplitude of the 11A16 input signal.

Specification (Step Response)

The system (mainframe/11A16) aberrations should not exceed 5% peak and 8% peak-to-peak.

Specification (Bandwidth)

A peak-peak measurement at 120 MHz \geq 78% of the amplitude at 50 kHz.

Setup to Examine Amplifier Step Response

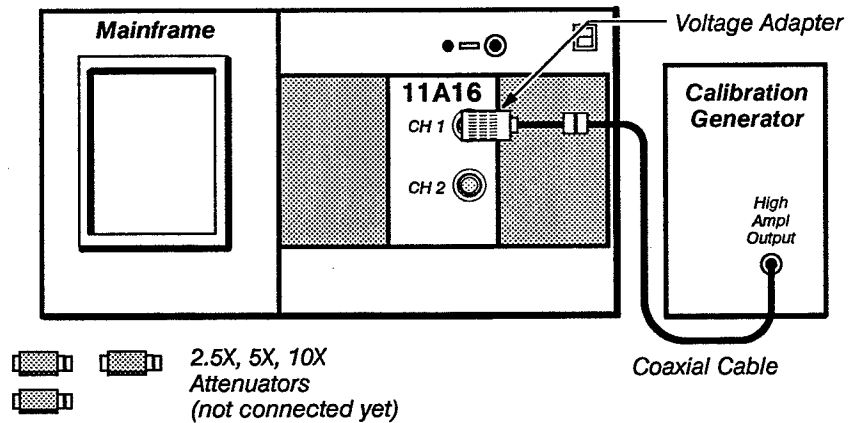

Steps Necessary to Examine Amplifier Step Response

- Step 1: First **Initialize** the mainframe settings, then perform the following settings in the order listed:

Calibration generator

Function switch High Ampl
 Period 1 μ s
 Pulse Amplitude 500 mV p-p

Center Plug-in

CH 1 Display on/off on

Mainframe

Vert Size 100 mV/div
Main Size 500 ns/div

Main Pos position positive-going edge to first graticule line from left edge of graticule

The following settings will horizontally expand the displayed waveform.

Mainframe

Main Size 2 or 5 ns/div depending on mainframe

Main Pos position positive-going edge between the first and second graticule lines from the left edge of the graticule

Vert Offset position top of step 2.5 divisions above the center horizontal graticule line

WAVEFORM major menu

Acquire Desc pop-up menu

Average N **On**

Set Avg N **8**

Vertical Size resolution (11400)

Vert Size knob label touch

Numeric Entry & Knob Res pop-up menu **Fine**

Vertical Size (DSA 600)

Vert Size FINE button press

Vert Size (Fine) knob 5-division step amplitude display

Vert Offset (Coarse) knob position top of trace to the center horizontal graticule line

The following settings will vertically expand the displayed waveform.

Vert Size (Coarse) set to 10% of present readout (~10 mV/div)

Vert Offset (Coarse) position top of trace to the center horizontal graticule line

- Step 2: Examine the displayed system response waveform and measure the aberrations. The aberrations should be within 5% peak (2.5 divisions) and 8% peak-to-peak (4 divisions). (You can use Δ Vert cursors or **Horizontal Bars** to measure this amplitude.)

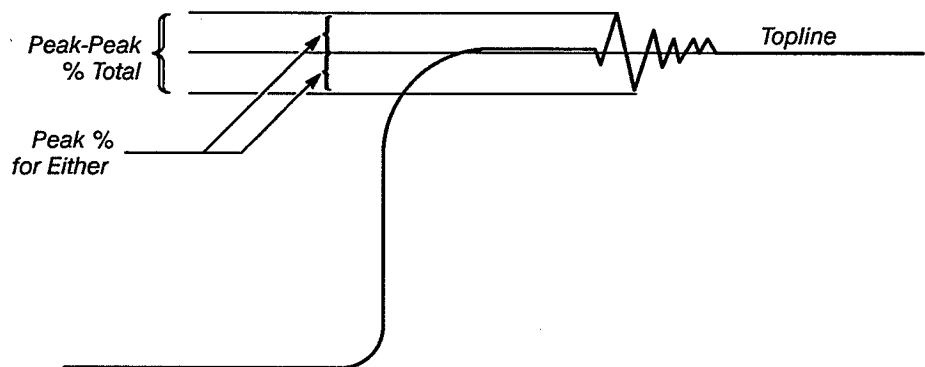

Figure 2-2 — Measurement of Plug-in Contribution to Aberrations

- Step 3: Repeat Step 1 beginning with the Mainframe **Vert Size** setting and proceeding through Step 2 in this procedure, until all CH 1 Deflection Factors in Table 2-3 are examined for aberrations. Do not change the Calibration Generator Pulse Amplitude; instead use the attenuator specified in the second column of Table 2-3.
- Step 4: Press the CH 1 Display on/off button (off). Press the CH 2 Display on/off button (on).
- Step 5: Verify CH 2 by moving the Voltage Adapter and cable to CH 2 and repeating Step 1 through Step 3 in this procedure.

Table 2-3 – Deflection Factors and Associated Test Conditions

Vert Size (Deflection Factor)	Attenuator Between Pulser and Adapter	Peak Amplifier Aberrations¹	Peak-to-Peak Amplifier Aberrations¹
100 mV/div	none	5%	8%
50 mV/div	none	4.5%	7%
20 mV/div	2.5X	4.5%	7%
10 mV/div	5X	4.5%	7%
5 mV/div	10X	4.5%	7%
2 mV/div	10X + 2.5 X	4.5%	7%
1 mV/div	10X + 5X	4.5%	7%

¹This aberration percentage does not include the mainframe aberration.

Setup to Check Amplifier Bandwidth

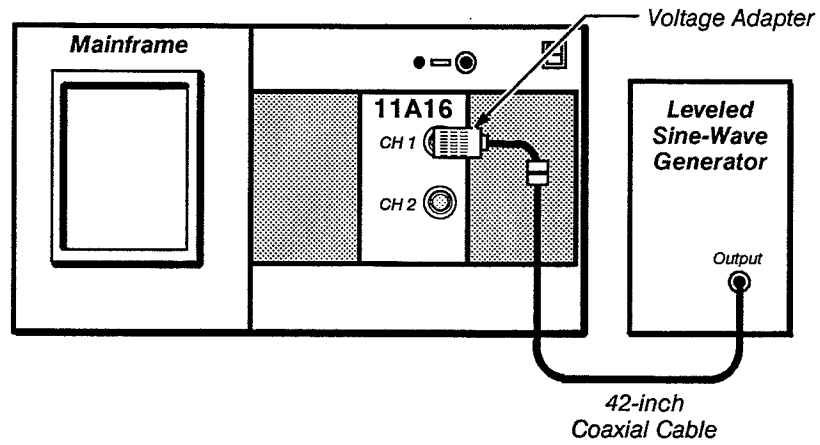

Steps Necessary to Check Amplifier Bandwidth:

The specifications for Amplifier Bandwidth are located on page 2-13.

- Step 1: First **Initialize** the mainframe settings, then perform the following settings in the order listed:

Center Plug-in

CH 1 Display on/off on

Leveled sine wave generator

Frequency 500 kHz

Mainframe

Vert Size 500 mV/div

Main Size 10 μ s/div

Acquire Desc pop-up menu

Average N **On**

Set Avg N **128**

- Step 2: Set the leveled sine-wave generator for 3 V peak-peak (6 div).
- Step 3: Select the **Peak-Peak** measurement to measure the peak-to-peak amplitude of the waveform. Be sure the mainframe trigger is stable. Record the **Peak-Peak** measurement for the reference waveform.
- Step 4: Set the leveled sine wave generator Frequency control to the maximum bandwidth frequency specified for the mainframe/11A16 combination, 120 MHz. This limit is displayed as **BW Limit** (WAVEFORM major menu, **Input Parameters** pop-up menu).
- Step 5: Set the **Main Size** to 5 ns/div.
- Step 6: Check that the **Peak-Peak** measurement is at least 2.34 V (78% of the peak-peak amplitude measured in Step 3).

- Step 7: Set the CH 1 display on/off button to off.
- Step 8: Move the Voltage Adapter and coaxial cable to the CH 2 input and set its Display on/off button to on.
- Step 9: Perform the Steps 1 to 6 for the CH 2 input.

**Procedure 4
Overload**

This procedure shows the setup and lists the steps necessary to check the input overload response. Its purpose is to verify that the 11A16 responds properly to overload conditions by turning coupling off.

Specification

Coupling changes to Off within 2 seconds.

Setup to Check Overload

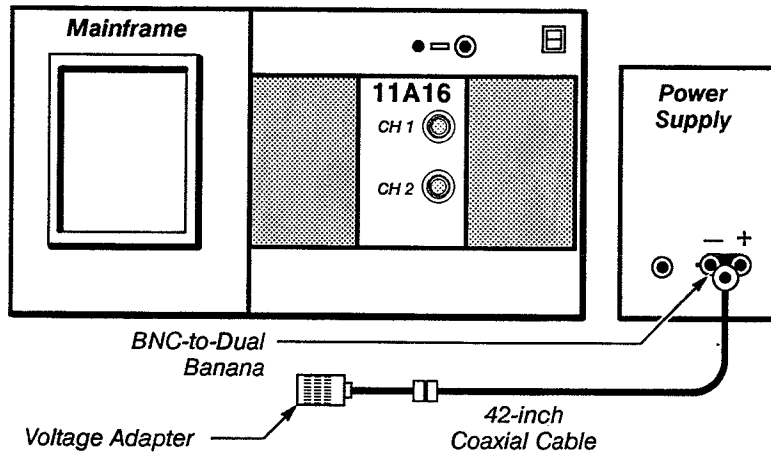

Steps Necessary to Check Overload

- Step 1: First **Initialize** the mainframe settings, then perform the following settings in the order listed:

- Center Plug-in
 - CH 1 Display on/off on
- Mainframe
 - Vert Size** 50 mU/div
 - Input Parameters (DSA 600)** touch
 - Coupling C1 and C2** DC
 - Coupling (11400)**
 - C1 and C2 DC
- Power supply
 - Volts 4 V
 - Current Limit 400 mA



*In the following steps, **IMMEDIATELY** disconnect the cable from the input if the coupling does not change within 2 seconds.*

- Step 2: Ensure that CH 1 is selected by touching its waveform on the display or by pressing the CH 1 Display on/off button twice.

- Step 3: Observe major menu status of **Coupling** (11400) or **Input Parameters** (DSA 600) as you connect the Voltage Adapter/coaxial cable from the power supply to the CH 1 input.
- Step 4: *Examine* that **Coupling** changes to **Off**.
- Step 5: Disconnect the power supply at the input.
- Step 6: Repeat Steps 2 through 5 for the CH 2 input.
- Step 7: Set the **Coupling** for CH1 and CH 2 to **DC**.
- Step 8: Set **Vert Size** to 2 U/div.
- Step 9: Set the power supply output to 12 V.
- Step 10: Connect the power supply to the CH 1 input using the 42-inch coaxial cable.
- Step 11: *Examine* that **Coupling** changes to **Off**.
- Step 12: Disconnect the power supply at the input.
- Step 13: Set the CH 2 Display on/off to on.
- Step 14: Repeat Steps 10 through 13 for the CH 2 input.

Procedure 5 Input Resistance

This procedure shows the setup and lists the steps necessary to check input resistance. Its purpose is to verify that input resistance is within the proper range.

Specification

Input resistance is $50\ \Omega$ within 1.5% ($\pm 0.75\ \Omega$).

Setup to Check Input Resistance

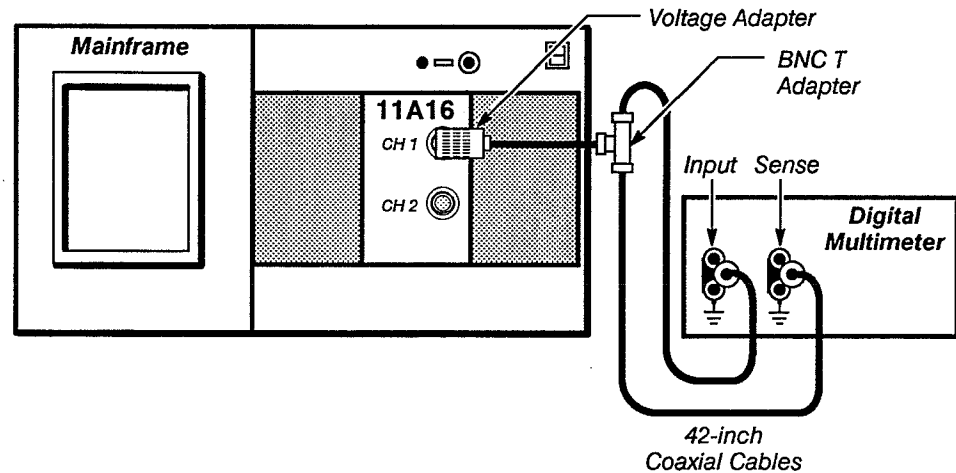

Procedure to Check Input Resistance

- Step 1: First **Initialize** the mainframe settings, then perform the following settings in the order listed:

Mainframe no setting changes
Center Plug-in
 CH 1 Display on/off on
Digital multimeter (DMM)
 Resistance mode 4-Wire

- Step 2: *Examine* that CH 1 input resistance is $50\ \Omega$ within $\pm 0.75\ \Omega$.
- Step 3: Repeat Input Resistance Check (Step 2) with the **Vert Size** set to 500 mV/div, then 50 mV/div.
- Step 4: Move the Voltage Adapter from CH 1 to CH 2 and repeat Steps 2 and 3 for the CH 2 input.

Procedure 6 DC Balance

This procedure shows the setup and lists the steps necessary to check DC balance. Its purpose is to confirm that DC balance can be accomplished accurately. The position of the displayed trace with no input signal applied is examined. This procedure must be performed immediately (5 minutes) after Enhanced Accuracy calibration.

Specification

Refer to Table 2-4.

Setup to Check DC Balance

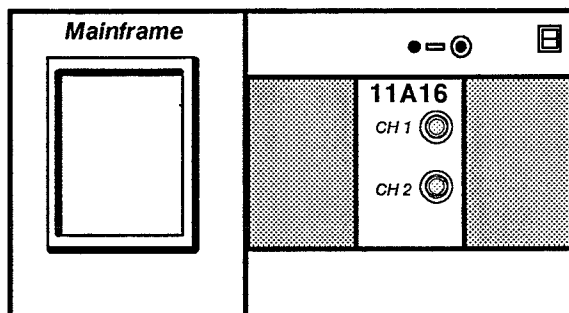

Steps Necessary to Check DC Balance

- Step 1: First run the Enhanced Accuracy calibration (if it has not been run in over 5 minutes) by pressing the ENHANCED ACCURACY button twice in succession. Enhanced Accuracy is achieved after several minutes.
- Step 2: **Initialize** the mainframe settings, then perform the following settings in the order listed:

Center plug-in

CH 1 Display on/off on

Mainframe

Vert Size 1 U/div

Main Pos -25.5 μ S

WAVEFORM major menu

BW Limit (11400) 20 MHz

Input Parameters (DSA 600) touch

Bandwidth 20 MHz

Acquire Desc

Average N On

Set AvgN 32

MEASUREMENT major menu

Measurement Mean

Mean touch

Data Interval whole zone

- Step 3: Check that the Mean readout is within the appropriate Error Limit listed in Table 2-4.
- Step 4: Repeat Step 3 for each Vert Size setting in Table 2-4.
- Step 5: Set the CH 1 Display on/off to off.
- Step 6: Set the CH 2 Display on/off to on.
- Step 7: Repeat Steps 1 to 4 for the CH 2 input.

Table 2-4 – 11A16 DC Balance Error Limits

11400-Series Shift		
Vert Size	(± div)	Error Limit
1 U/div	0.07	70 mU
100 mU/div	0.07	7.0 mU
50 mU/div	0.1	5.2 mU
20 mU/div	0.11	2.2 mU
10 mU/div	0.12	1.2 mU
5 mU/div	0.14	0.7 mU
2 mU/div	0.2	0.4 mU
1 mU/div	0.3	0.3 mU

Procedure 7 Vertical Accuracy

This procedure shows the setup and lists the steps necessary to check vertical accuracy. Its purpose is to verify that the accuracy of DC levels is within the proper range. The instrument must be checked immediately after Enhanced Accuracy calibration.

Specification

Measurement of $\pm 0.2\%$ Peak-Peak resolution for the 11400 Series mainframe.

Measurement of $\pm 0.8\%$ Peak-Peak resolution for the DSA 600 Series mainframe.

Setup to Check Vertical Accuracy

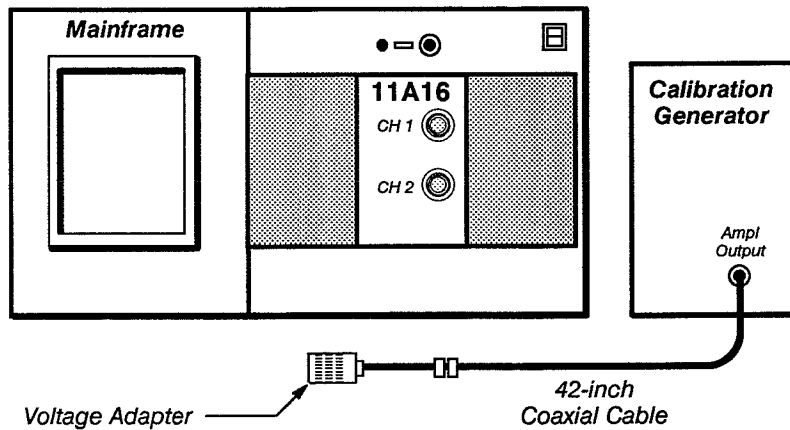

Steps Necessary to Check Vertical Accuracy

- Step 1: First run the Enhanced Accuracy calibration by pressing the ENHANCED ACCURACY button twice in succession. Enhanced Accuracy is achieved after several minutes.
- Step 2: Now **Initialize** the mainframe settings, then set the following parameters in the order listed:

Center Plug-in

CH 1 Display on/off on

Calibration generator

Mode Std Ampl

Amplitude Output 10 V (provides 5 V across 50 Ω input)

Mainframe

Main Size 100 μ s/div

Acquire Desc

Average N (if available) On

No. Average 32

Vert Offset 0 U

Coupling

C1 and C2 DC

- Step 3: Connect the Calibration Generator output to the CH 1 input using the 42-inch coaxial cable and the Voltage Adapter.
- Step 4: Set the **Vert Size** to 1 V/div.
- Step 5: Set the **Vert Offset** to +2.5 V.
- Step 6: Select the **Peak-Peak** measurement (Measure major menu).
- Step 7: *Check* that the measurement is 5 V, ± 50 mV (with averaging on).
- Step 8: Press the CH 1 Display on/off button to turn CH 1 off. Press the CH 2 Display on/off button to turn CH 2 display on.
- Step 9: Repeat the Steps 2 through 7 for the CH 2 input.

Procedure 8 Bandwidth Limit

This procedure shows the setup and lists the steps necessary to check bandwidth limiting. Its purpose is to verify that rise time is within the proper range for a particular bandwidth limit filter.

Specification

At a bandwidth limit of 100 MHz, rise time is: 2.45 ns < > 4.55 ns.

At a bandwidth limit of 20 MHz, rise time is: 12.3 ns < > 22.7 ns.

Setup to Check Bandwidth Limit

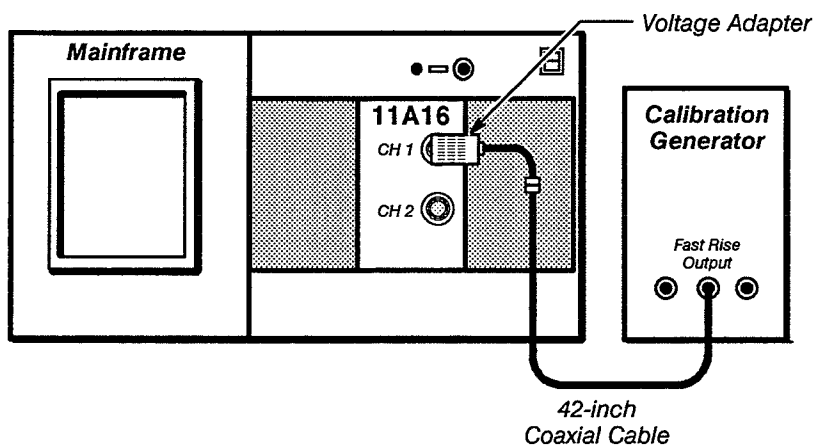

Steps Necessary to Check Bandwidth Limit

- Step 1: First **Initialize** the mainframe settings, then set the following parameters in the order listed:

Center Plug-in

CH 1 Display on/off on

Calibration generator

Period 1 μ s

Mode Fast Rise

Pulse Amplitude 5 divisions (1 V p-p)

Mainframe

Main Size 5 ns/div

Main Pos -25.5 ns (position rising edge
at screen center)

Vert Size 200 mV/div

Vert Offset -500 mV

WAVEFORM major menu

BW Limit (11400) **100 MHz**

Input Parameters (DSA 600) touch

Bandwidth **100 MHz**

- Step 2: With these settings the display should have a five division peak-peak signal.
- Step 3: Select the **Rise Time** measurement (MEASURE major menu).
- Step 4: *Check* that the rise time is between 2.45 and 4.55 ns.
- Step 5: Set the **BW Limit** (11400) or **Bandwidth** (DSA 600) limit to **20 MHz**.
- Step 6: *Check* that the rise time is between 12.3 and 22.7 ns.
- Step 7: Set the CH 1 Display on/off to off.
- Step 8: Set the CH 2 Display on/off to on.
- Step 9: Repeat Steps 1 through 6 for the CH 2 input.

Procedure 9 AC Coupling

This procedure shows the setup and lists the steps necessary to check AC coupling. Its purpose is to verify that AC coupling operates accurately.

Specification

Bottom of square wave is near the center graticule line.

The waveform is vertically centered on the screen and resembles Figure 2-3.

At 1 mV/div the waveform is within 0.3 divisions of vertical center.

Setup to Check AC Coupling

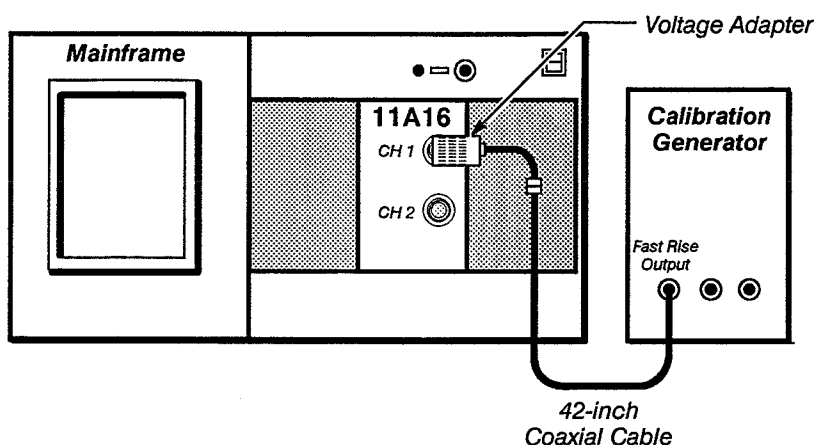

Steps Necessary to Check AC Coupling

- Step 1: First **Initialize** the mainframe settings, then perform the following settings in the order listed:

Center Plug-in

CH 1 Display on/off on

Calibration generator

Mode (-) Fast Rise

Amplitude 1 V (5 divisions)

Period 10 ms

Mainframe

Vert Size 200 mV/div

Main Size 2 ms/div

- Step 2: *Examine* that the bottom of the square wave is near the center graticule line as shown at the top of Figure 2-3.
- Step 3: Select AC Coupling for the CH 1 input.
- Step 4: *Examine* that the displayed waveform is vertically centered and that it resembles the bottom waveform in Figure 2-3.

- Step 5: Set the CH 1 Display on/off to off.
- Step 6: Move the Voltage Adapter and coaxial cable to the CH 2 input.
- Step 7: Set the CH 2 Display on/off to on and repeat Steps 1 through 4 for the CH 2 input.

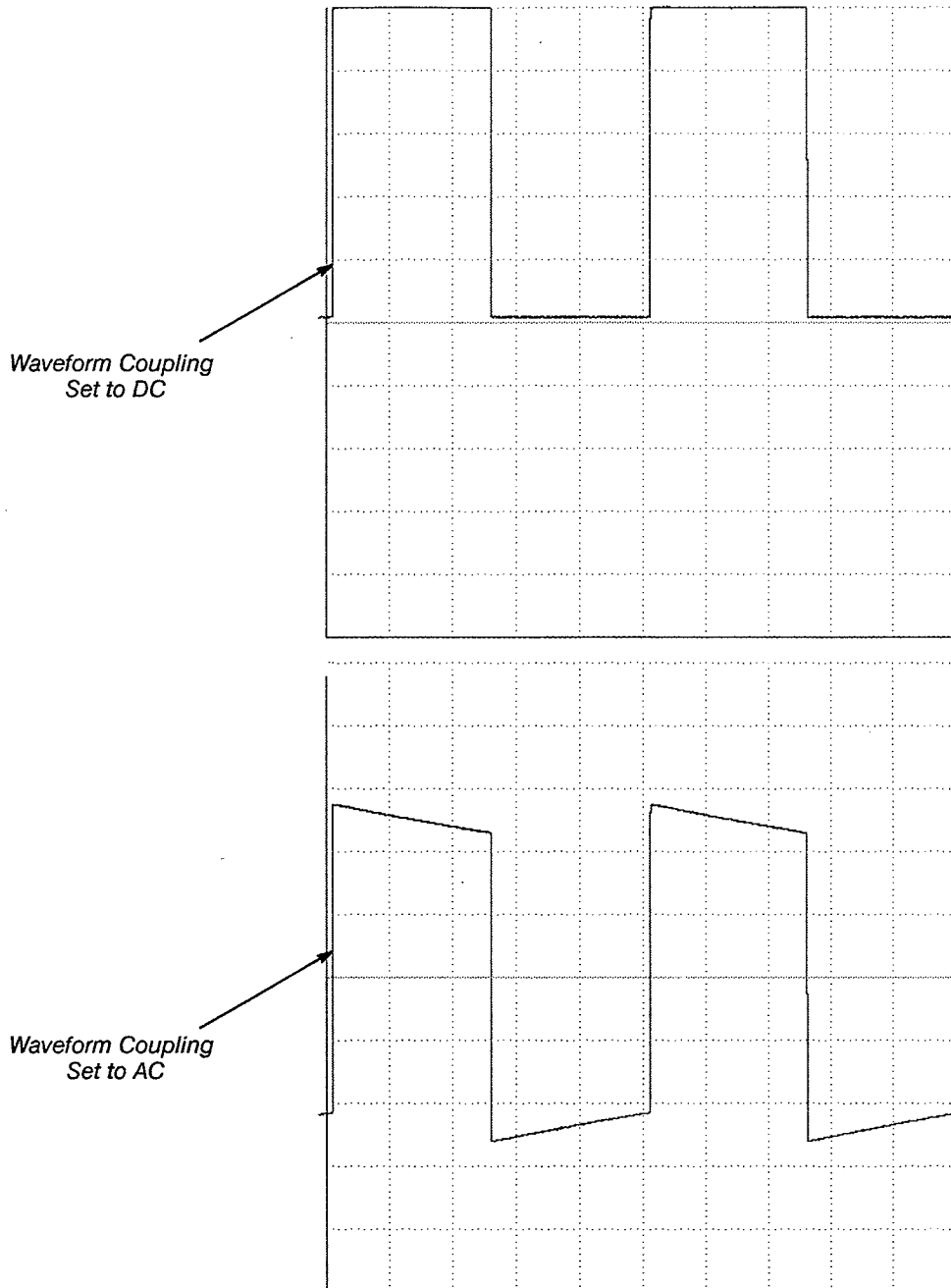

Figure 2-3 — Waveform with DC Coupling (Top) and AC Coupling (Bottom)

- Step 8: Remove the Voltage Adapter from the CH 2 input.
- Step 9: Set CH 2 **Vert Size** to 1 mU/div.
- Step 10: *Check* that the trace is within 0.3 divisions of vertical center.
- Step 11: Set the CH 2 Display on/off to off.
- Step 12: Set the CH 1 Display on/off to on.
- Step 13: Repeat Steps 9 and 10 for CH 1.

Procedure 10
 ΔV DC Accuracy

This procedure shows the setup and lists the steps necessary to check ΔV DC Accuracy. Its purpose is to confirm that the 11A16 can be accurately calibrated. Check ΔV DC Accuracy immediately after an Enhanced Accuracy calibration.

Before checking ΔV DC Accuracy you must characterize your mainframe by using the following procedure that corresponds to your mainframe series.

Specification

ΔV DC Accuracy within $\pm 0.53\%$ from 2 mV to 2 V/div; within $\pm 0.78\%$ at 1 mV/div.

Setup to Characterize the 11400 or DSA 600 Series Mainframe

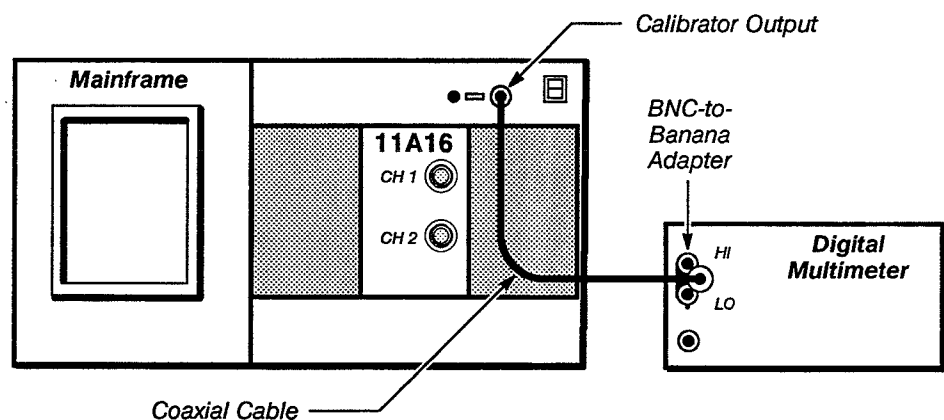

Steps Necessary to Characterize the 11400 Series Mainframe

Step 1: Set the following parameters:

- Center plug-in no setting changes
- Digital multimeter (DMM)
 - Mode DC
 - Range Auto (Range 10 V)
- Mainframe
 - UTILITY major menu **Extended Diagnostics**
 - SUBSYSTEM** **Digitizer**
 - Block** **Points Acq**
 - Area** **FP Cal Refs**
 - Routine** **FP -10.000 V**
 - Run** touch

Step 2: Record the DMM *absolute value*.

Step 3: Select **Exit**.

Step 4: Select **FP + 9.9951 V**.

- Step 5: Select **Run**.
- Step 6: Record the DMM absolute value.
- Step 7: Select **Exit**.
- Step 8: Select **Exit Diagnostics**.
- Step 9: Add the DMM absolute values of the readings obtained in Steps 2 and 6. Divide the result by 19.9951 V to obtain the mainframe calibration voltage reference characterization factor. This factor is used in the "Procedure to Test the Amplifier".

Steps Necessary to Characterize the DSA 600 Series Mainframe

- Step 1: Set the following parameters:

Center plug-in no setting changes
Digital multimeter (DMM)
 Mode DC
 Range Auto (Range 10 V)
Mainframe
 UTILITY major menu Calibrator
 Frequency DC
 Adjust Amplitude Adjust amplitude to -10 V.

- Step 2: Record the DMM absolute value.
- Step 3: Adjust Amplitude to +9.9951V.
- Step 4: Record the DMM absolute value.
- Step 5: Add the DMM *absolute values* of the readings obtained in Steps 2 and 4. Divide the result by 19.9951 V to obtain the mainframe calibration voltage reference characterization factor.

Setup to Check the 11A16 ΔV DC Accuracy

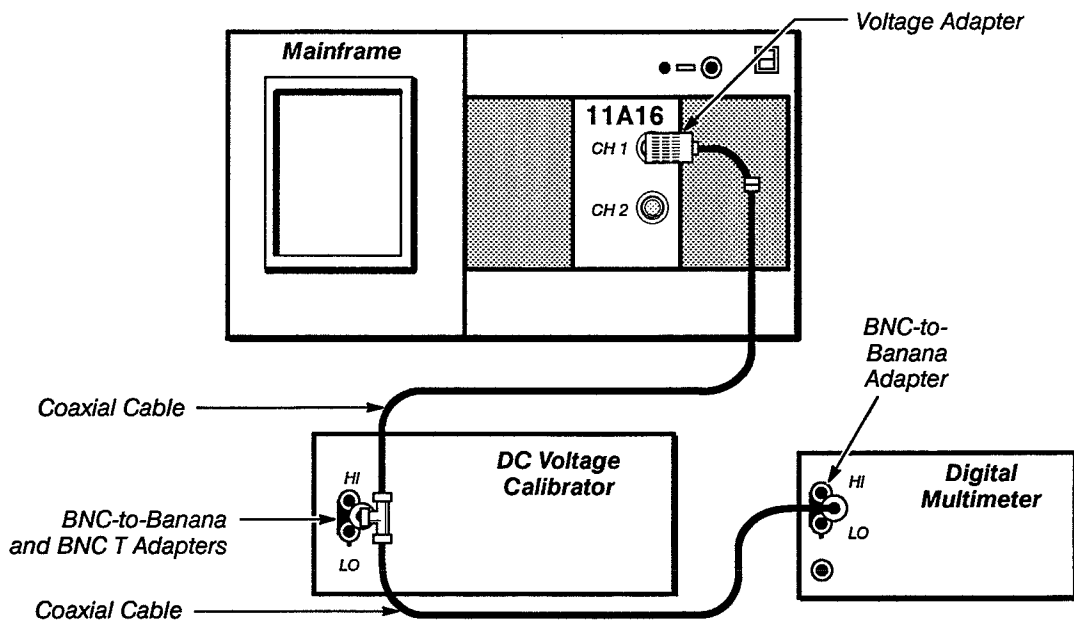

Steps Necessary to Check the 11A16 ΔV DC Accuracy

- Step 1: First **Initialize** the mainframe settings, then perform the following settings in the order listed:

Center plug-in

CH 1 Display on/off on

Mainframe

WAVEFORM major menu

BW Limit (11400) 20 MHz

Input Parameters (DSA 600) touch

Bandwidth 20 MHz

Acquire Desc pop-up menu

Average N On

DC Voltage Calibrator

On/Standby on

50 Ω Override on

If the environment is electrically noisy, connect a capacitor (at least 0.1 μ F) across the input terminals of the DC Voltage Calibrator.

- Step 2: Press the Enhanced Accuracy button twice to initiate Enhanced Accuracy calibration and ensure peak performance of the system.

Immediately after self-calibration has completed and passed, perform this procedure for each channel.

- Step 3: Select the **Mean** measurement in the MEASURE major menu, and set the **Data Interval** to **Whole Zone** in the **Mean** pop-up menu.
- Step 4: Set **Compare** to **On**. For the 11400 Series, select **Stat, Comp, & Def** in the MEASURE major menu, and then select **Compare Options**. For the DSA600 Series, select the second page of the MEASURE major menu, then select **Compare & Defaults**.
- Step 5: Set **Vert Size** to the first Vertical Size entry in Table 2-5. Fine knob resolution will be required to select the 49.8 and 23 mV settings.
- Step 6: Set the DC Voltage Calibrator polarity to minus (-), then set its output level to the appropriate Deflection Volts setting from Table 2-5.
- Step 7: Save the current **Mean** measurement as the reference value in the menu that you used to set Compare on in Step 4.
- Step 8: Set the DC Voltage Calibrator polarity to plus (+), leaving its output level set to the Deflection Volts setting used in Step 6.
- Step 9: Clear the waveform data by selecting **Remove/Clr Waveform**, then selecting **Clear** waveform name (wfm 1) in the pop-up menu. This will restart waveform averaging and give a measurement based on the new input signal.
- Step 10: Now calculate the difference between the delta-mean value and the combined applied signal levels to get the ΔV DC error:

Read the current Δ **Mean** measurement.

Divide the Δ **Mean** value by the mainframe characterization factor that you determined earlier in this procedure.

Subtract from this value, 2 times the present Deflection Volts setting to obtain the ΔV DC error.

- Step 11: *Check* that the ΔV DC error obtained in Step 10 is within the Error Limits given in Table 2-5.
- Step 12: Repeat Steps 5 through 11 for all Vertical Size settings listed in Table 2-5.

Table 2-5 – 11A16 DC Accuracy Error Limits

Vertical Size	Deflection Volts	Error Limits ($\pm V$)
1 V/div	4 V	42.4 mV
100 mV/div	400 mV	42.4 mV
50 mV/div	200 mV	1.06 mV
49.8 mV/div (Fine res)	200 mV	1.06 mV
23 mV/div (Fine res)	92 mV	.98 mV
20 mV/div	80 mV	.85 mV
10 mV/div	40 mV	.42 mV
5 mV/div	20 mV	.21 mV
2 mV/div	8 mV	.085 mV
1 mV/div	4 mV	.062 mV

Procedure 11 DC Offset Accuracy

This procedure shows the setup and lists the steps necessary to check DC Offset. Its purpose is to confirm that the amplifier can be accurately calibrated. This procedure does not test the mainframe calibration voltage reference accuracy or long term stability. Therefore, before checking DC Offset Accuracy you must characterize your mainframe by using the procedure corresponding to your series of mainframe. Check DC Offset Accuracy immediately after an Enhanced Accuracy calibration.

Specification

Refer to Table 2-6.

Setup to Characterize the 11400 or DSA 600 Series Mainframe

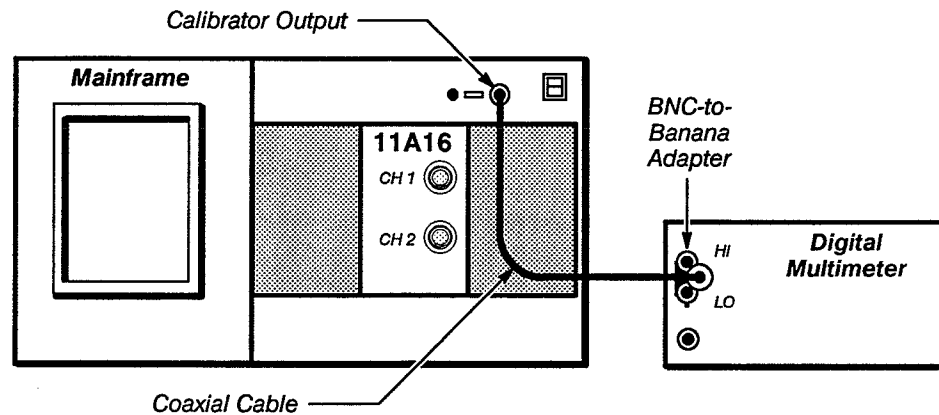

Steps Necessary to Characterize the 11400 Series Mainframe

This characterization procedure is identical to that performed in Procedure 10. You can use the mainframe calibration voltage reference characterization factor computed in Procedure 10 for the verification portion of this procedure.

Step 1: Set the following parameters:

Center plug-in	no setting changes
Digital multimeter (DMM)	
Mode	DC
Range	Auto
Mainframe	
UTILITY major menu	Extended Diagnostic
SUBSYSTEM	Digitizer
Block	Points Acq
Area	FP Cal Refs
Routine	FP -10.000 V
Run	touch

- Step 2: Record the DMM absolute value.
- Step 3: Press **Exit**.
- Step 4: Press **FP +9.9951 V**.
- Step 5: Press **Run**.
- Step 6: Record the DMM reading.
- Step 7: Press **Exit**.
- Step 8: Press **Exit Diagnostics**.
- Step 9: Add the absolute values of the DMM readings obtained in Steps 2 and 6. Divide the result by 19.9951 V to obtain the mainframe's calibration voltage reference characterization factor (which is used in the Procedure to Test the Amplifier).

Steps Necessary to Characterize the DSA 600 Series Mainframe

- Step 1: Set the following parameters:
 - Center plug-in no setting changes
 - Mainframe
 - UTILITY major menu Calibrator
 - Frequency** **DC**
 - Adjust Amplitude Adjust amplitude to -10 V.
 - Digital multimeter (DMM)
 - Mode DC
 - Range Auto
- Step 2: Record the DMM absolute value.
- Step 3: Adjust Amplitude to +9.9951V.
- Step 4: Record the DMM reading.
- Step 5: Add the DMM absolute values of the readings obtained in Steps 2 and 4. Divide the result by 19.9951 V to obtain the mainframe calibration voltage reference characterization factor.

Setup to Check the 11A16 DC Offset Accuracy

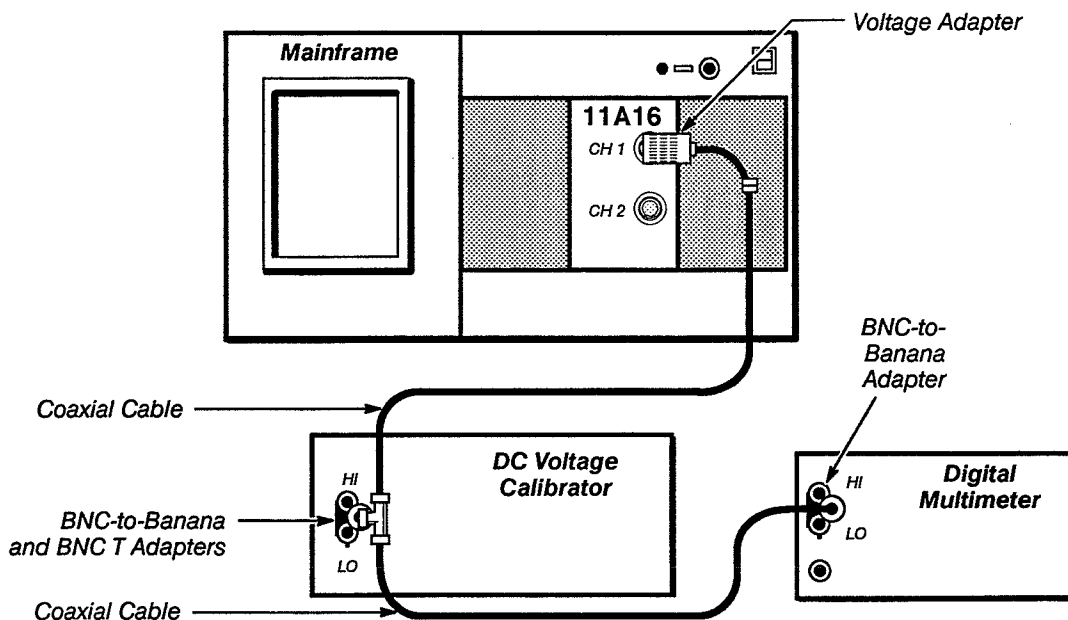

Steps Necessary to Check the 11A16 DC Offset Accuracy

- Step 1: First **Initialize** the mainframe settings, then perform the following settings in the order listed:

- DC Voltage Calibrator
 - On/Standby on
 - 50 Ω Override on
 - Output Level 0 V
- Center plug-in
 - CH 1 Display on/off on
- Mainframe
 - WAVEFORM major menu
 - (11400) BW Limit 20 MHz
 - (DSA600) Input Parameters touch
 - Bandwidth 20 MHz
 - Acquire Desc pop-up menu
 - Average N On

If the environment is electrically noisy, connect a capacitor (at least 0.1 μF) across the input terminals of the DC Voltage Calibrator.

- Step 2: Press the Enhanced Accuracy button twice. Immediately after self-calibration has completed and passed, perform this procedure for each channel.
- Step 3: Select the **Mean** measurement in the MEASURE major menu, and set the **Data Interval** to **Whole Zone** in the **Mean** pop-up menu.

- Step 4: Set **Compare** to **On**. For the 11400 Series, select **Stat, Comp, & Def** in the MEASURE major menu, and then select **Compare Options**. For the DSA600 Series, select the second page of the MEASURE major menu, then select **Compare & Defaults**.
- Step 5: Save the current **ΔMean** measurement as the reference value in the menu in which you set Compare to on in Step 4.
- Step 6: Set **Vert Size** to the first Vertical Size entry in Table 2-6.
- Step 7: Set **Vert Offset** to the corresponding Vertical Offset from Table 2-6.
- Step 8: Set the DC Voltage Calibrator to the current Vertical Offset divided by the characterization-factor which you computed earlier in this procedure.
- Step 9: Clear the waveform data by selecting **Remove/Clr Waveform**, then selecting **Clear** waveform name (wfm 1) in the pop-up menu. This will restart waveform averaging and give a measurement based on the new input signal.
- Step 10: Read the **ΔMean** measurement after it has stabilized. Subtract the Vertical Offset set in Step 7 from the current **ΔMean** reading to get the DC Offset error.
- Step 11: *Check* that the DC Offset error obtained in Step 10 is less than the Error Limit shown in Table 2-6.
- Step 12: Set **Vert Offset** to 0.
- Step 13: Repeat Steps 6 through 12 for each Vertical Size and Offset shown in Table 2-6.

Table 2-6 – 11A16 DC Offset Accuracy

Vertical Size	Vertical Offset	Error Limit (± Volts)
1 V/div	4 V	50 mV
0.1 V/div	4 V	14 mV
1 mV/div	1 V	2.4 mV
1 mV/div	800 mV	2.0 mV
1 mV/div	600 mV	1.6 mV
1 mV/div	400 mV	1.2 mV
1 mV/div	200 mV	0.8 mV

Procedure 12 Degauss Ability

This procedure shows the setup and lists the steps necessary to check probe degauss ability. Its purpose is to confirm that the 11A16 can degauss its current probe and zero its output signal. This procedure will verify that the front-end 11A16 circuitry such as the Power Amplifier, Hall Effect Amplifier, and the degauss Signal Generator are operating properly. Check degauss ability immediately after an Enhanced Accuracy calibration.

Specification

The mainframe zeros the displayed waveform to the horizontal center line within:

A6302 – 0.25 mA + 0.1 div

A6303 – 1.0 mA + 0.1 div

Setup to Check the 11A16 degauss Ability

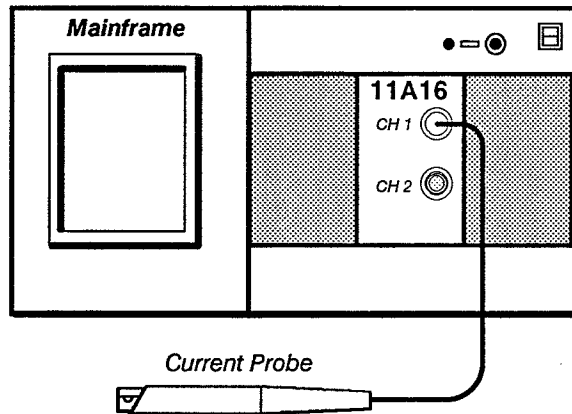

Steps Necessary to Check degauss Ability

- Step 1: First run the Enhanced Accuracy calibration by pressing the ENHANCED ACCURACY button twice in succession. Enhanced Accuracy is achieved after several minutes.
- Step 2: **Initialize** the mainframe settings, then perform the following settings in the order listed:

Center plug-in

CH 1 Display on/off on

Mainframe

Input Parameters (DSA 600) touch

Coupling C1 and C2 DC

Coupling (11400) DC

Vert Size 1 mA/div (5 mA/div for A6303)

Main Size 5 ms/div

Acquire Desc pop-up menu

Average N **On**
Set Avg N **32**

- Step 3: Ensure that the jaws are closed, then press the DEGAUSS button.
- Step 4: *Examine* that the message **DAC Overflow** is *not* displayed.
- Step 5: Set **Coupling** to **OFF**.
- Step 6: Adjust **Vert Offset** so that the trace is on the center graticule.
- Step 7: Set **Coupling** to **DC**.
- Step 8: Press the DEGAUSS button.
- Step 9: *Check* that the signal trace is vertically zeroed to the center graticule within the specifications given above.
- Step 10: Check CH 2 by moving the current probe to CH 2 and repeating Steps 2 through 9.

Procedure 13 Probe Calibration

This procedure shows the setup and lists the steps necessary to check probe calibration. Its purpose is to confirm that the mainframe and 11A16 can calibrate the current probe using the Current Loop adapter connected to the mainframe Calibrator BNC output. *DO NOT connect the Current Loop adapter at this time.* This procedure will further verify that the front-end 11A16 circuitry such as the Power Amplifier, Hall Effect Amplifier, and the Attenuators are operating properly.

Specification

The mainframe calibrates the current probe without a failure.

Setup to Check the 11A16 Probe Calibration

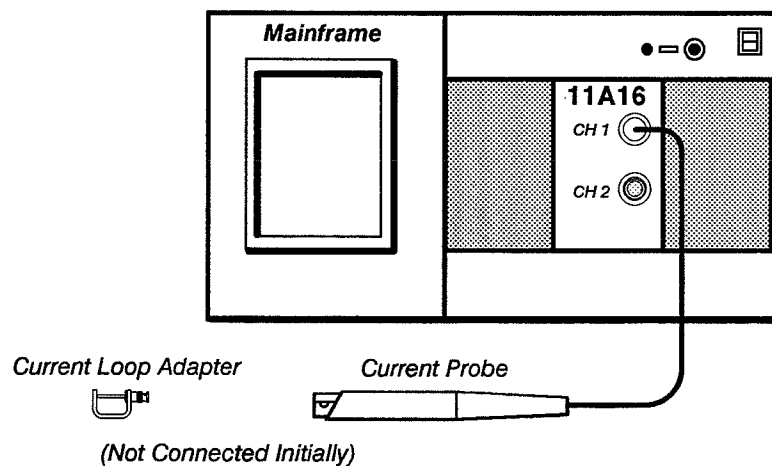

Steps Necessary to Check Probe Calibration

- Step 1: If the EA (Enhanced Accuracy) icon is not displayed, then press the ENHANCED ACCURACY button twice in succession.



Enhanced Accuracy should NOT be invoked when the Current Loop Adapter is connected to the calibrator output of the mainframe. The Current Loop Adapter places a considerable load on the precision voltage reference in the mainframe. During an Enhanced Accuracy calibration, the precision reference can be overloaded resulting in a calibration error.

Ensure that Enhanced Accuracy is in **Manual** mode by checking the **Instrument Modes** or **Modes** pop-up menu of the **Utility 1** major menu. Errors can occur if Enhanced Accuracy is automatically invoked during probe calibration.

- Step 2: **Initialize** the mainframe settings in the Utility menu.
- Step 3: Press the CH 1 display On/Off button to display CH 1.

- Step 4: Press the DEGAUSS button. Let the probe warm up for 10 minutes.
- Step 5: Install the Current Loop Adapter on the mainframe CALIBRATOR output BNC. Attach the current probe head to the test bar of the Current Loop Adapter.

The arrow on the probe indicates the direction of positive "current" flow. *The arrow must be pointing away from the mainframe.*

- Step 6: Select the **Probes** pop-up menu in the **Utility 1** major menu.
- Step 7: Select the probe channel in the **Calibrate**, **Deskew**, and **Compensate Probes** section of the **Probes** pop-up menu located in the UTILITY major menu. For example, C1 for center plug-in compartment, CH 1.

If the polarity of the probe is incorrect or if the probe is not properly connected, the following warning message is displayed during the calibration:

Connect Probe to Calibrator and Restart Operation

Correct this problem by reversing the current probe connection and restarting calibration.

- Step 8: *Examine* that one of the following messages is displayed after probe calibration and deskewing complete:

Probe Cal Complete; Deskew Passed (A6302) or,

Probe Cal Complete; Deskew Failed (A6303)

NOTE: *If you are using an A6303 probe or an A6302 with a cable longer than 2 meters, the Deskew portion will likely fail due to the long time delay through the probes. The failure is due to the 15 ns deskew limit of the mainframe and is acceptable.*

Ignore the Compensation message, since no compensation is required for a current probe.

- Step 9: Move the current probe to CH 2 and repeat Steps 2 through 7 for the CH 2 probe.
- Step 10: To complete the procedure, *remove the Current Loop Adapter* and exit the **Probes** pop-up menu by selecting **Exit Comp**.

If Enhanced Accuracy is invoked when the Current Loop Adapter is attached, calibration can be corrupted.

Maintenance

This section provides you with preventive maintenance, ordering information, sensitive component information, techniques to remove/replace the FRUs, and troubleshooting of the 11A16. Corrective Maintenance is limited to the replacement of FRUs or modules. Service beyond this level must be done by your Tektronix service center.

Preventive Maintenance

Preventive maintenance can prevent the 11A16 from failing and increase its reliability. Cleaning and visual inspection is all that is required for preventive maintenance. To clean or inspect the internal boards of the 11A16 you must remove its side shields.

11A16 Side Shield Removal

The side shields, top and bottom frames, and front panel reduce radiation of electromagnetic interference (EMI) from the 11A16. They also reduce the amount of dust reaching the interior. Therefore, when you are not maintaining the 11A16, keep the side shields in place.

Remove a side shield as follows:

- Step 1: Pry the side shield from the rear of the 11A16.
- Step 2: Lift up on the shield.
- Step 3: Gently remove the shield from the grooves in the frame and front panel.

Install a side shield as follows:

- Step 1: Position the shield over the frame grooves.
- Step 2: Slide the front lip of the side shield under the front panel.
- Step 3: Press down on the shield until it snaps into place. (Pressure must be applied along the full length of the frames to secure the shield.)

Note that the 11A16 will not slide into the mainframe if the side shields are not fully seated in the frames.

Cleaning

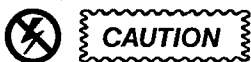

Use anti-static protection to prevent static damage to components.

The 11A16 should be cleaned as often as operating conditions require. Dirt on a component acts as an insulating blanket and prevents efficient heat dissipation. Dirt also provides an electrical conduction path, which may cause the 11A16 to fail.

Exterior – dust can be removed with a soft cloth or small brush. A brush is particularly useful for dislodging dirt in and around the front panel switches. Remove the side shields before cleaning.

Interior – cleaning of the 11A16 is seldom required. If the interior of the 11A16 accumulates dust or dirt, clean with dry, low-velocity air. Remove stubborn dirt with a soft brush or a cloth dampened with a mild detergent and water solution. (A cotton-tipped applicator is useful for cleaning in narrow spaces or for cleaning delicate components.) Finally, remove any cleaning residue by wiping with a damp washcloth.



To prevent damage from electrical shorts, the boards and components must be dry before applying power.

Visual Inspection

The 11A16 should be inspected occasionally for loosely-seated or heat-damaged components. The corrective procedure for most visible defects is replacement of the part. Particular care must be taken if heat-damaged parts are found, since overheating usually indicates other problems.

Diagnostic Troubleshooting

The mainframe automatically performs a series of diagnostic tests when it is powered on and the microprocessor unit (MPU) is reset. The first set of diagnostic tests are the Kernel Tests which determine if the 11A16 kernel systems are operating properly. If these are successful, then the Self Tests are executed to verify the functionality of the 11A16 subsystems. Any failure causes the mainframe to enter Extended Diagnostics and to display the error index code(s) in a diagnostic menu.

The Kernel tests, Self-Tests, and Extended Diagnostics produce and format error index codes differently, so these error index codes are discussed separately.

Kernel Tests

Kernel Tests are done each time the front-panel ON/STANDBY switch is set to ON. The mainframe and 11A16 perform Kernel Tests on their microprocessor subsystems and Self Test Diagnostics on all major circuits.



Turning the mainframe power off during the execution of the diagnostic tests may result in losing some or all of the non volatile RAM (NVRAM) data (for example, calibration constants). This loss of data may cause the mainframe to operate unpredictably. If this occurs, refer to Restoring Calibration Data later in this section.

If any of the kernel tests fail, then it is unlikely that the 11A16 can communicate failure information to the mainframe. The flashing of a fault code on the front panel CH 1 and CH 2 LEDs indicates which kernel test is failing.

The following description explains how to read the fault code:

- If the 11A16 Kernel tests detect a fault, then the CH 2 LED is flashed eight times.
- If the CH 1 LED is flashed during a cycle of the CH 2 LED, then the test corresponding to the current count is the one that failed. Refer to the timing diagram in Figure 3-1 for an example LED fault code. The timing diagram illustrates a test number 2 failure.

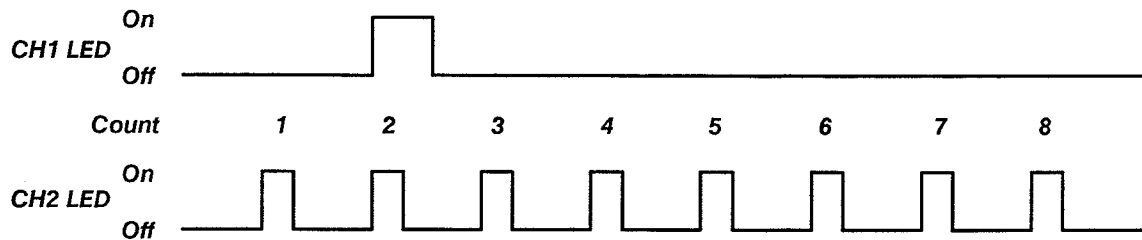

Figure 3-1 – Sample LED Fault Code Timing Diagram

The three kernel tests are:

- **Test 1: The EPROM Checksum test**—computes a checksum of the content of the firmware EPROM. This calculated checksum is then compared with a checksum stored in the EPROM. If the checksums do not match, the test fails, and fault code 1 is reported. After the front panel LEDs flash to report the fault code, the 11A16 attempts to begin normal operation however it is unlikely that the 11A16 can function properly with a bad EPROM Checksum.
- **Test 2: The Nonvolatile RAM (NVRAM) test**—verifies that the NVRAM is functioning properly. Since the NVRAM contains calibration information which must remain undamaged, this test does not alter critical data. If the testing algorithm detects a failure, then the 11A16 reports a fault code of 2 and repeatedly loops the NVRAM test. The 11A16 continues looping the NVRAM test until the mainframe is powered off (ON/STANDBY switch is set to STANDBY). Until the condition causing the NVRAM test to fail is corrected, the mainframe does not recognize the 11A16.

The NVRAM test could corrupt data stored in the NVRAM if the mainframe is powered off and on during this test. If corruption occurs, then the Calconstant Checksum is also corrupted. At the next power-on, the 11A16 resets the calibration constants to default EPROM settings and reports a plug-in (11A16) Calconstant Checksum Error during normal power-on diagnostics. To properly calibrate the mainframe and 11A16, you must initiate an Enhanced Accuracy calibration.

- **Test 3: The Housekeeper IC test**—verifies the functionality of the Housekeeper IC (also referred to as the SDI IC). The Housekeeper IC performs the following housekeeping chores of the 11A16: channel sequencing, refreshing the analog control voltage system (AVCS), and providing serial data communications with the mainframe. This test exercises the IC, and records the ICs signature. If the resulting signature of the Housekeeper IC does not match a known good signature, then this test fails

and the 11A16 reports a fault code of 3 and repeatedly loops on the Housekeeper IC test.

After all kernel tests have been completed and successfully passed, the 11A16 initializes its settings and communicates with the mainframe.

Self Tests

After passing the kernel tests the mainframe requests that the 11A16 execute its Self Test routines (unless the mainframe Self Tests are disabled). If the mainframe returns to normal operation or enters into a new configuration calibration, this indicates successful completion of the Self Tests.

Self Tests diagnostics verify the following:

- Probe coding
- Calibration (cal) constant checksums
- Calibration (cal) constant values
- Analog-to-digital (ADC) and digital-to-analog (DAC) converters
- ± 15 V power fuses
- Input signal path

Extended Diagnostics

After all Self Tests and Extended Diagnostics are executed, any resultant error index codes appear on the display next to the associated circuit block names in the Extended Diagnostics mainframe menu. Each circuit block that experiences failure will indicate the first error encountered and the number of failures in the Block. To get a more complete list of the error index codes in a Block, select a failed Block and then the Area selector. To display the lowest level test routines in the selected Area, select the Routine. The currently selected Block, Area, and Routine are shown.

Several diagnostic operating mode selectors are available on the screen. Refer to your mainframe *User Reference* for more information on Extended Diagnostics and Extended Test menus and operation.

Enhanced Accuracy Errors

Enhanced Accuracy Errors specify faulty FRUs that are preventing the mainframe from entering its Enhanced Accuracy state. See your mainframe *User Reference* for more information about Enhanced Accuracy.

Error Index Codes

Error Index Codes are five digit codes whose first character indicates the subsystem or 11A16 tested. The last four digits are hexadecimal (hex) numbers that indicate the Block, Area, Routine and failure identity. For example, R1241 is decoded as follows:

R	Right plug-in (facing the mainframe front panel)
1	Block name – plug-in
2	Area name – Group I
4	Routine name – Checksum Probe
1	Failure Identity – specific failure mode

The first character of an error index code indicates the compartment in which the 11A16 is installed:

L	Left
C	Center
R	Right

The tables in this section, list the four-digit failure code only; the prefix L, C, or R is omitted.

Front-panel controls are active during the Self-Test sequence and any disturbance could cause a test failure.

Error index codes are divided into three tables: Kernel test error codes (Table 3-1), Self-Tests/Extended Diagnostic error indexes (Table 3-2), and Enhanced Accuracy error indexes (Table 3-4). Each table lists suspect FRUs in the order of highest to lowest probability. For FRU identification and replacement information, refer to page 3-11.

Table 3-1 lists the error codes that result from the Kernel Tests.

Table 3-1 – 11A16 Kernel Error Index Codes

Error Code	Suspect Module, Hybrid, or IC FRU(s)	Suspect Board
1	EPROM, MPU	Main
2	NVRAM	Main
3	SDI, MPU	Main

Table 3-2 lists the error codes that result from the Self-Tests and Extended Diagnostics.

Table 3-2 – Self-Tests/Extended Diagnostics Error Index Codes

Error Code	Suspect Module, Hybrid, or IC FRU(s)	Suspect Board
1111		Main
1121 ¹	NVRAM	Main
1131 ¹	NVRAM	Main
1211		Main
1221	FUSE	Main
1311	SDI, SMPLHD1 ² , SMPLHD2 ²	Main
1811		Main
1821		Main
1831	Amp	Main
1841	Amp	Main
1851	Amp	Main
1861	Amp	Main
1871		Main
1881		Main
1891		Main
18A1		Main

¹When the NVRAM is replaced a new User Identification (UID) must be entered before this error can be cleared. See Programming the Unit Identification page 3-35.

²The specific SMPLHD failure is determined by decoding the Actual data produced by the diagnostic test. Decoding is discussed below. If both SMPLHD boards have failures, the SDI is suspect.

Decoding an SMPLHD Failure—The **Actual** data accompanying an X1311 error code can be decoded to identify the suspect Sample and Hold board. The **Actual** data is a hexadecimal (hex) number. Convert this hex number to binary, then determine which bits are 1. Table 3-3 shows the suspect board and the board pin number for the failed ACVS channel. Refer to Figure 3-2 to locate a failed SMPLHD board.

The hex data code 0040 is equivalent to the binary 0000 0000 0100 0000. The single 1 is in Binary Bit position 6 which points to the SMPLHD2 board.

If both SMPLHD boards have failures this would point to the SDI IC or other common circuitry.

Table 3-3 – Sample and Hold Board Failure Codes

Binary Bit	Suspect SMPLHD FRU	Board Pin #
15	SMPLHD2	20
14	SMPLHD2	22
13	SMPLHD1	20
12	SMPLHD1	22
11	SMPLHD2	19
10	SMPLHD2	23
9	SMPLHD1	19
8	SMPLHD1	23
7	SMPLHD2	17
6	SMPLHD2	14
5	SMPLHD1	17
4	SMPLHD1	14
3	SMPLHD2	15
2	SMPLHD2	16
1	SMPLHD1	15
0	SMPLHD1	16

Table 3-4 lists the error codes that result from the Enhanced Accuracy tests. (Enhanced Accuracy is available after the system has a 20-minute warmup period.)

Table 3-4 – Enhanced Accuracy Error Index Codes

Error Code	Suspect Module, Hybrid, or IC FRU(s)	Suspect Board
1411	ATTN1	Main
1421	AMP	Main
1431	AMP	Main
1441	AMP	Main
1451	AMP	Main
1461	AMP	Main
1471	AMP	Main
1481	AMP	Main
1491	AMP	Main
1511	PROBE	
1521	PROBE	
1531		Main
1541		Main
1551		Main
1611	ATTN2	Main
1621	AMP	Main
1631	AMP	Main
1641	AMP	Main
1651	AMP	Main
1661	AMP	Main
1671	AMP	Main
1681	AMP	Main
1691	AMP	Main
1711	Probe	
1721	Probe	
1731		Main
1741		Main
1751		Main

Other Messages

Other messages can be displayed by the mainframe. These are described below.

Calibrating a New Configuration

When a plug-in unit is first installed in a mainframe or when it is moved to a different compartment, the mainframe enters the new configuration mode. After power-on diagnostics, it will recalibrate itself for the new configuration. During calibration, the screen displays the message **Powerup new configuration partial calibration occurring**. If calibration is successful, the screen displays a completion message, and the mainframe begins normal operation.

Restoring Calibration Data

If the mainframe is powered off during probe calibration, Self Tests, Extended Diagnostics, or other system calibration or evaluation activity, internal NVRAM data can be corrupted. If the **Extended Diagnostic** menu is displayed after power on, then this corruption might be the cause of the apparent failure.

If the **Extended Diagnostics** menu displays a **Cksm Probe** error, use the following procedure to restore normal operation:

- Step 1: Recalibrate the probes.
- Step 2: Execute the Self Tests and confirm that the tests pass.

If the **Extended Diagnostics** menu again displays a **Cksm Probe** error or any new error, then use the following procedure to restore normal operation:

- Step 3: Exit the **Extended Diagnostic** menu.
- Step 4: Wait for self calibration to complete and pass.
- Step 5: Execute the Self Tests and confirm that these tests pass.

If this procedure does not restore normal operation, the 11A16 requires repair.

Conventional Troubleshooting

This section lists faulty FRUs and symptoms that power-on diagnostics can not detect. After determining the suspect FRU, refer to Table 3-8 to locate the appropriate technique(s) to replace it.

Front Panel Connector Troubleshooting

A faulty Front Panel Connector/Cable assembly could cause a communication loss between the Front Panel board and the Main board.

Fuse Troubleshooting

To find a defective fuse, remove the 11A16 from the mainframe, and use a digital multimeter to check for continuity across each fuse. Figure 3-2 shows fuse locations. Fuses are checked by a diagnostic test.

Darlington NPN or PNP Power Transistor Troubleshooting

When using a current probe, a faulty Darlington NPN (NPNTRAN) or PNP (PNPTRAN) Power Transistor could prevent input signal amplification. Use a digital multimeter to check for *at least* 2–3 K Ω resistance between the emitter and collector (the two outer leads of each transistor). Additionally, the heatsink tab is the collector and the square board pad is the emitter. A blown fuse will have little affect on this measurement.

Probe Connector Troubleshooting

A faulty probe connector assembly (PCON) could cause an intermittent or complete loss of input signal. Check the continuity of each wire.

Relay Troubleshooting

The 11A16 has four relays, K1-K4, located on each Attenuator board. See Figure 3-3 for relay locations. A faulty relay could disable the following 11A16 functions for a signal channel:

- AC/DC switching, K4.
- Channel Coupling ON/OFF, K1.
- Attenuation range, (X10) K2.
- Attenuation range, (X100) K2 & K3.

Jumper Troubleshooting

The misplacement of pin jumpers could cause unpredictable operation of the 11A16.

Field Replaceable Unit (FRU) Guide

This section lists abbreviations of board FRUs, component/module FRUs, and error index codes. The error index code tables list the hybrid, integrated circuit (IC), module, or board FRU(s) suspected of causing each error. The FRU(s) in each category are listed in most-to-least probable cause (assuming only one error is indicated). If any errors occur, inspect the suspect FRU for loose connections and components and then repeat the diagnostic test. If any errors recur, then replace the suspect FRU(s) with a good FRU(s). Verify that the new FRU is a correct replacement for the old FRU. If the old FRU contains firmware, be sure that the new firmware version is either the same or updated.

Abbreviations of FRU Names

Table 3-5, Board FRUs, lists the abbreviation used in the Suspect Board FRU(s) column of Tables 3-1, 3-2, and 3-4.

Table 3-5 – Board FRUs

Abbreviation	Name	Designator
Main	Main board	A1
ATTN1 & 2	Attenuator boards	A1A3, A1A4
SMPLHD1 & 2	Sample & Hold boards	A1A1, A1A2
FPB	Front Panel boards	A2, A3

Abbreviations of Component Names

Table 3-6, Component/Module FRUs, lists the abbreviation used in the Suspect Module, Hybrid, or IC FRU(s) column of Tables 3-1, 3-2, and 3-4.

Table 3-6 – Component/Module FRUs

Abbreviation	Name	Designator
AMP1	Tek M377 Vertical Amplifier, CH 1	U220
AMP2	Tek M377 Vertical Amplifier, CH 2	U260
ATTN1	Attenuator, channel 1	J310
ATTN2	Attenuator, channel 2	J380
EPROM	Firmware	U1080
FPB	Front Panel board (identical units)	A2, A3
FRPAN	Front Panel	–
FUSE	± 15 V power Amp fuses (3/4 Amp)	F500, F610
HTSNK	Heat Sink	–
HYP	Hypcon Assembly	–

Table 3-6 – Component/Module FRUs (Cont.)

Abbreviation	Name	Designator
JMPERS	Jumpers	–
NPNTRAN	Darlington NPN Power Transistors	Q600, Q690
NVRAM	Memory	U1000
PCON	Probe Connector assembly	J1001, J1002
PNPTRAN	Darlington PNP Power Transistors	Q601, Q691
PROBE	A6302 or A6303 Current Probe	–
RELAY	Attenuator board relays	K1, K2, K3, K4
SDI	Tek M382A Serial Data Interface	U850
SMPLHD1	Sample and Hold board, CH 1	J640
SMPLHD2	Sample and Hold board, CH 2	J650

Ordering Parts

If you find that it is necessary to replace a FRU or a FRU IC, it can be ordered from a Tektronix service center. When ordering replacement parts, include the following information:

- plug-in type
- plug-in serial number
- Description of the part (if electrical, include the circuit number)
- Tektronix part number

If a part you order has been replaced with a different or improved part, your local Tektronix service center or representative will contact you concerning any changes.

Static-Sensitive Device Classification



Static discharge can damage any semiconductor in the 11A16.

The 11A16 contains electrical components that are susceptible to damage from static discharge. Refer to Table 3-7, Relative Susceptibility to Damage from Static Discharge, for the relative susceptibility of various classes of semiconductors. Static voltages of 1 kV to 30 kV are common in unprotected environments.

Observe the following precautions to avoid damage:

- Minimize handling of static-sensitive components.
- Transport and store static-sensitive components or assemblies in their original containers, either on a metal surface or conductive foam. Label any package that contains static-sensitive assemblies or components.

- Wear a wrist strap while handling these components to discharge the static voltage from your body. Servicing static-sensitive assemblies or components should be performed only at a static-free work station. The use of the static control mat is recommended.
- Clear anything from the work station surface that is capable of generating or holding static charge.
- Keep component leads shorted together with conductive foam.
- Pick up components by the body, never by the leads.
- Do not slide components over any surface.
- Avoid handling components in areas that have a floor or a work-surface that is capable of generating static charge.

Table 3-7 – Relative Susceptibility to Damage from Static Discharge

Semiconductor Classes	Relative Susceptibility Levels ¹
MOS or CMOS microcircuits, and discrete or linear microcircuits with MOS inputs (most sensitive)	1
ECL	2
Schottky signal diodes	3
Schottky TTL	4
High-frequency bipolar transistors	5
JFETs	6
Linear microcircuits	7
Low-power Schottky TTL	8
TTL (least sensitive)	9

¹Voltage equivalent for levels.

1 = 100 to 500 V

2 = 200 to 500 V

3 = 250 V

4 = 500 V

5 = 400 to 600 V

6 = 600 to 800 V

7 = 400 to 1000 V (est.)

8 = 900 V

9 = 1200 V

(The voltage equivalent is the voltage discharged from a 100 pF capacitor through a resistance of 100 Ω.)

Removing/Replacing FRUs

Once you have determined the suspect FRU remove the 11A16 side shields as discussed in the Preventive Maintenance section of Maintenance, find the FRU on the 11A16 Main board by referring to Figure 3-2, then refer to Table 3-8, to find the removal/replacement procedure(s).

The exploded-view drawing in *Replaceable Parts* can be useful in the removal/replacement procedures that follow.

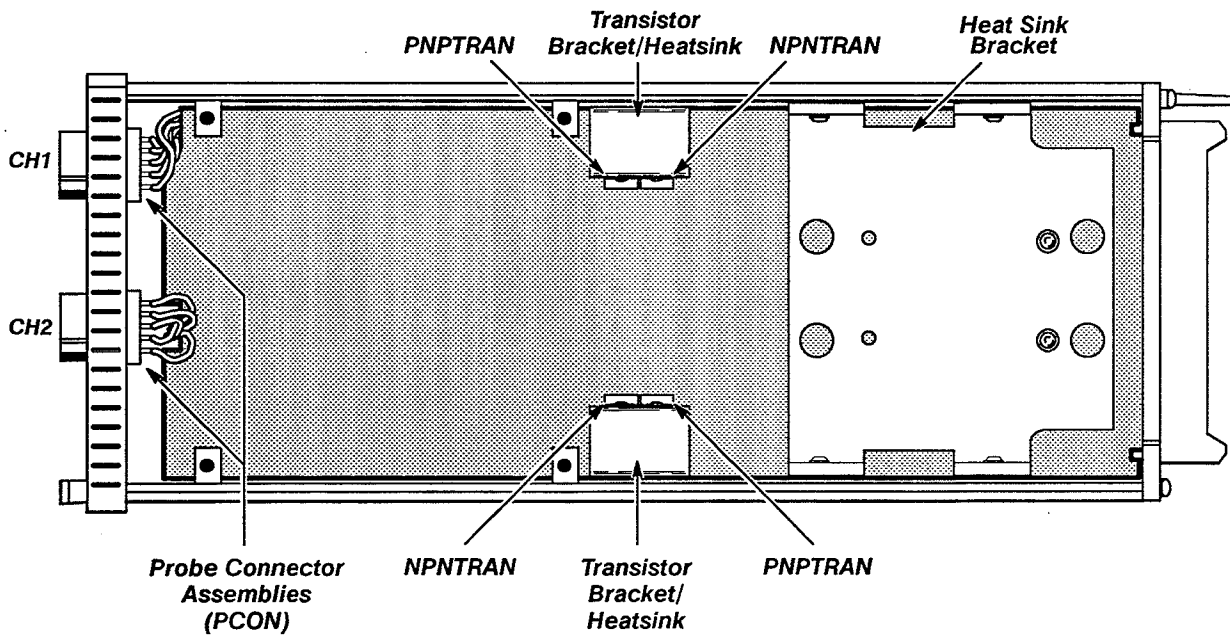
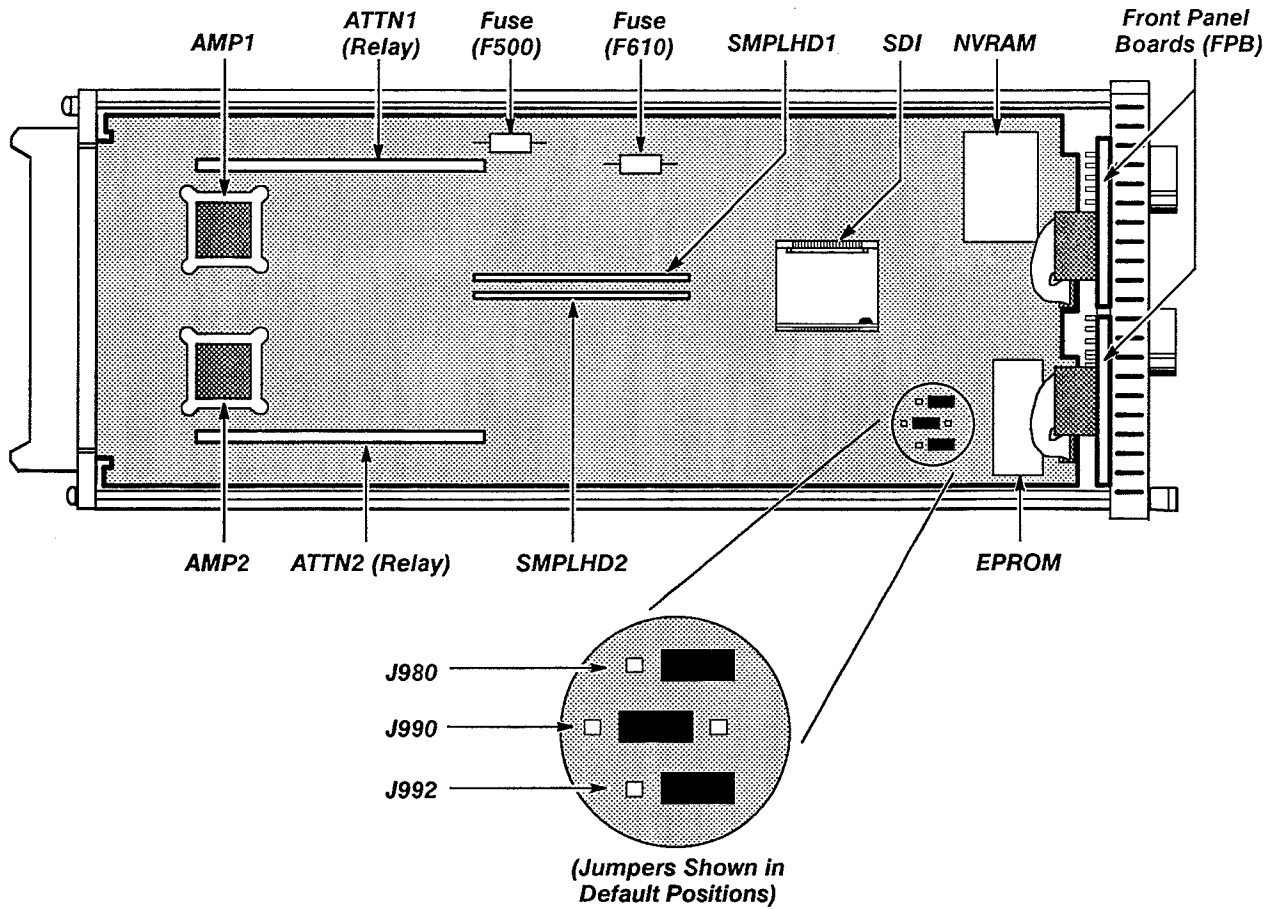
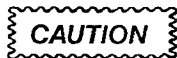

Figure 3-2 – FRU and FRU IC Locator



To avoid damage to the 11A16, set the mainframe ON/STANDBY switch to STANDBY, and remove the 11A16 from the mainframe before removing or replacing FRUs. If the mainframe green indicator light remains lit when the ON/STANDBY switch is in the STANDBY position, then the switch was internally disabled after the servicing of the Power Supply module. To enable the ON/STANDBY switch, refer to Corrective Maintenance in your mainframe Service Reference.

Table 3-8 – FRU Removal/Replacement Procedure Cross Reference

FRU to be Replaced	Procedure(s) to Reference During Removal/Replacement	Page
AMP1 or AMP2	Removing/Replacing a Heat Sink Bracket	3-24
	Removing/Replacing a Hypcon Assembly	3-25
	Removing/Replacing a FRU IC	3-32
ATT1 or ATT2	Removing/Replacing Heat Sink Bracket	3-24
	Removing/Replacing an Attenuator board	3-16
EPROM	Removing/Replacing a FRU IC	3-32
PCON	Removing/Replacing a Front Panel	3-21
	Removing/Replacing a Connector Assembly	3-17
	Removing/Replacing a Multi-pin Connector	3-31
Front Panel	Removing/Replacing a Front Panel	3-21
FPB	Removing/Replacing a Front Panel	3-21
	Removing/Replacing a Multi-pin Connector	3-31
	Removing/Replacing a Front Panel board	3-24
FUSE	Removing/Replacing a Fuse	3-24
Heat Sink Bracket	Removing/Replacing a Heat Sink Bracket	3-24
Jumper	Removing/Replacing a Pin Jumper	3-31
Main board	Removing/Replacing an Attenuator	3-16
	Removing/Replacing a Multi-Pin Connector	3-31
	Removing/Replacing a Heat Sink Bracket	3-24
	Removing/Replacing a Main board	3-28
	Programming the Unit Identification	3-35
NPNTRAN	Removing/Replacing Darlington Pair Power Transistors	3-20
NVRAM	Removing/Replacing a FRU IC	3-32
	Programming the Unit Identification	3-35
PNPTRAN	Removing/Replacing a Darlington Pair Power Transistor	3-20
RELAY (K1-K4)	Removing/Replacing a Relay	3-31
SDI	Removing/Replacing a Slam Pack IC	3-33
SMPLHD	Removing/Replacing a Sample and Hold board	3-20

Removing/Replacing an Attenuator Board

See Figure 3-3 for connector locations.

Remove an Attenuator board as follows:

- Step 1: Disconnect the coaxial connector from the input of the Attenuator board.
- Step 2: Carefully desolder the Attenuator board from the Main board. Removal is easier if you first cut the pins at the base of the Attenuator board then desolder and pull each pin free from the Main board.

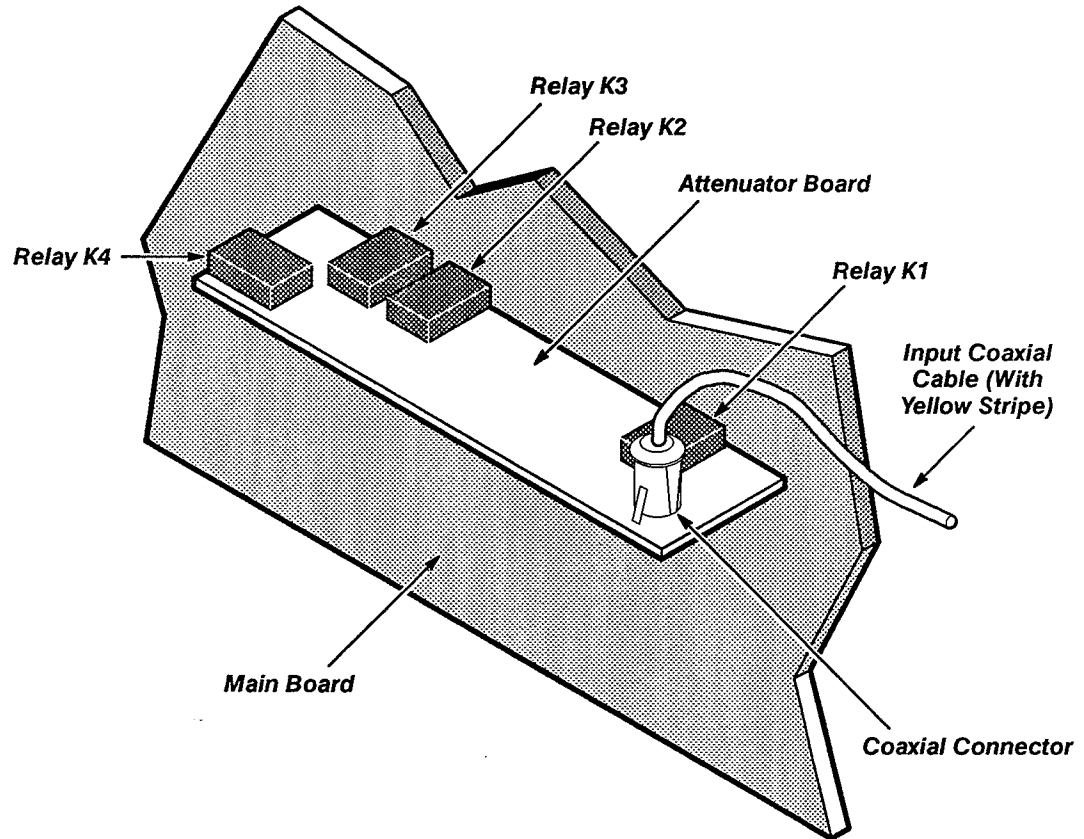

Figure 3-3 – Removing/Replacing an Attenuator

- Step 3: Remove the Attenuator board from the Main board.

Replace an attenuator as follows:

- Step 1: Align the Attenuator board square pins with the cleared holes on the Main board. The fifth pin is missing to aid in alignment.
- Step 2: Note the proper orientation, then insert the Attenuator board into the receptacle on the Main board.



Do not apply force to any subcomponents on the Attenuator board.

- Step 3: Resolder the Attenuator board pins to the Main board connections.

-
- Step 4: Reconnect the coaxial connector to the input of the Attenuator board. When engaging these connectors, use the following precautions:
 - Ensure that the center conductor of the cable is straight. If necessary, straighten the conductor with clean pliers to avoid contamination.
 - Insert the connector straight into the receptacle.
 - While you insert the connector, look through the slot in the outer receptacle to ensure that the center conductor enters its receptacle properly.

Removing/Replacing the Connector Assembly

See Figures 3-2, 3-4, 3-5, 3-7, 3-10, and 3-12 for connector wiring, and the locations of screws and index marks. You can verify a faulty connector by trying a known good probe.

Remove the connector assembly as follows:

- Step 1: Remove the Front Panel (See Removing/Replacing the Front Panel).
- Step 2: Disconnect the coaxial connector at the Main board and at the Attenuator board. Disconnect the 10-pin connector from the Main board.
- Step 3: Disconnect the multi-pin connectors that connect the Front Panel boards to the Main board. (Note the position of the multi-pins index triangle to ensure that you can correctly replace this connector.)
- Step 4: Remove the four Torx head screws (see Fig. 3-7) that secure the current probe connector assembly to the front subpanel.
- Step 5: Slip the nut plate out of the way to gain access to the faulty probe connector.
- Step 6: Remove the current probe connector assembly from the 11A16.

Replace the current probe connector assembly by referring to Figures 3-4 and 3-5 then proceeding as follows:

- Step 1: Align the 12-pin connector with the tang slot at the bottom as shown in Figure 3-4.
- Step 2: Insert the 12-pin connector through the Front Panel from the rear. Put the nut plate on behind the connectors.

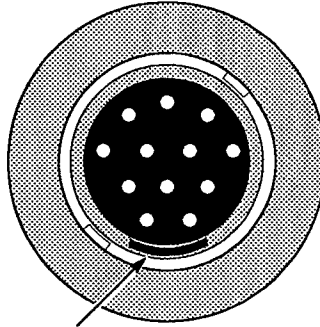

Tang Slot at Bottom

Figure 3-4 – Proper Orientation of the Current Probe Connector

- Step 3: Replace the four Torx head screws that secure the connector and nut plate to the front subpanel.
- Step 4: Reconnect the 10-pin connector to its receptacle on the Main board.
- Step 5: Connect the coaxial cable with a *yellow stripe* to the appropriate Attenuator board and connect the coaxial cable with *no stripe* to the Main board. Ensure that the center conductor of the coaxial wire is straight. If necessary, straighten the conductor with clean pliers to avoid contamination.
- Step 6: Reconnect the multi-pin connectors from the Front Panel boards to the Main board.
- Step 7: Replace the Front Panel (See *Removing/Replacing the Front Panel*).

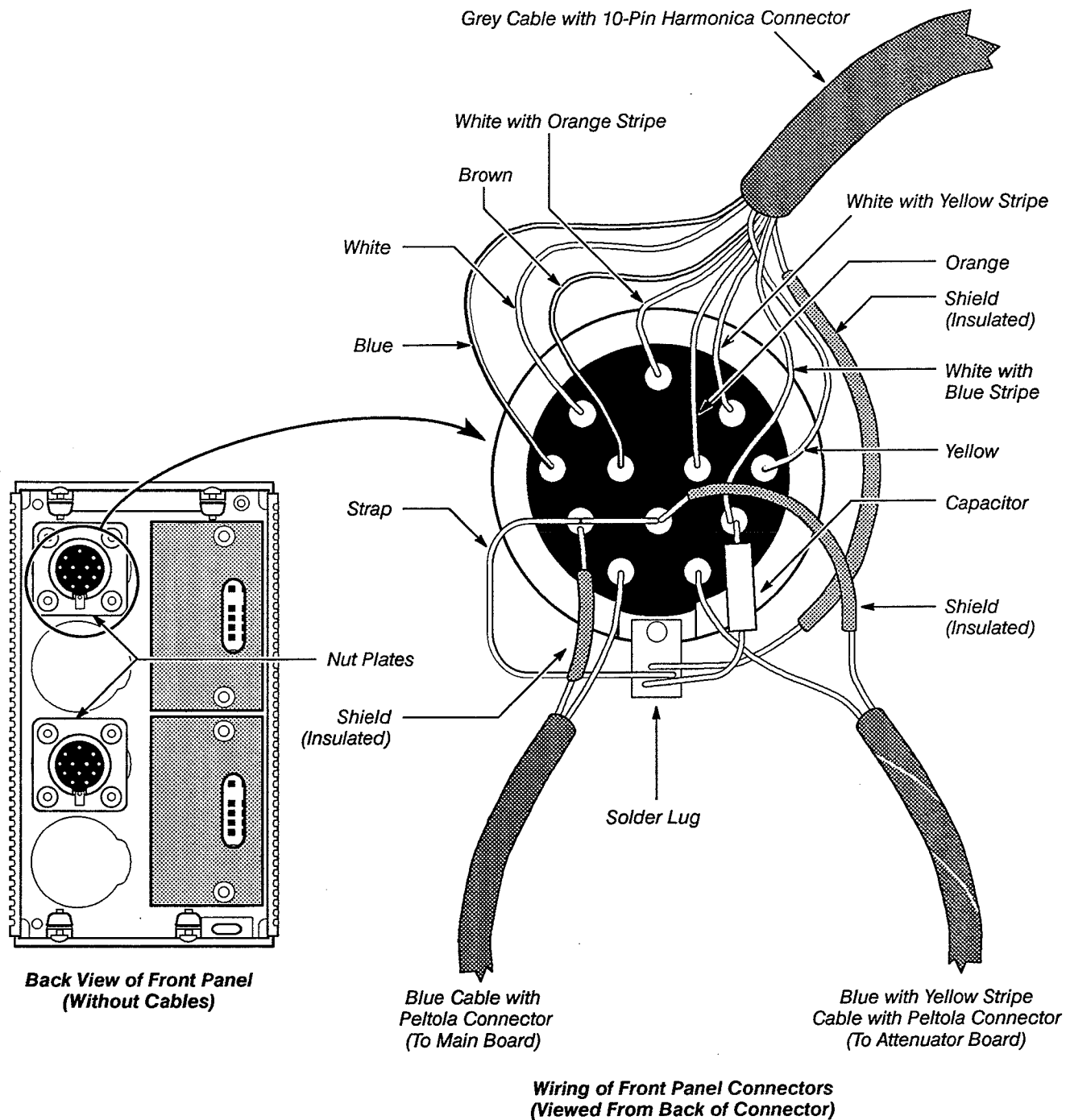

Figure 3-5 — Installation Wiring for Current Probe Connector

Removing/Replacing a Darlington Power Transistor

To check the transistors in circuit, ensure that the power is off, then set a digital multimeter to the 1 k Ω range and measure the emitter to collector (two outside pins) resistance. This should measure 2 k Ω or greater in circuit, with or without a good fuse and if the transistors are not shorted collector-to-emitter (the most common failure mode). You can also identify the emitter and collector by the square board pad for the emitter and the the heatsink tab tied to the collector. We recommend that both transistors of a pair be replaced, even if only one appears defective. Refer to Figure 3-2 and remove a transistor pair as follows:

- Step 1: Remove the Torx screws that hold the transistor heatsink bracket to the plug-in side rail.
- Step 2: Remove the Torx screws that hold the transistor pair to the heatsink bracket. Save the heat transfer material for reinstallation.
- Step 3: Desolder the transistors from the Main board.

Replace a transistor by:

- Step 1: Orient the new transistors properly onto the heatsink, aligning the tab holes with the threaded hole in the heatsink. Note that the NPN is on the right and PNP is on the left (see Fig. 3-2).
- Step 2: Place the heat transfer material between the transistor tab and the heatsink and install the Torx screws, shoulder washers, and flat washers to secure the transistors to the heatsink. Do not tighten the screws at this time. Refer to the exploded view, Figure 5-1.
- Step 3: Place (but do not solder) the full length transistor leads in the appropriate Main board holes, then install the heatsink on the plug-in side rail.
- Step 4: Solder the transistors to the Main board. Now tighten the Torx screws securing the Darlington Pair transistors to the heatsink. This assembly order minimizes stress on the transistor leads.

Removing/Replacing a Sample and Hold Board

The diagnostics are the primary means for troubleshooting Sample and Hold boards. Refer to Figure 3-2 to identify the two Sample and Hold boards.

Remove a Sample and Hold board as follows:

- Step 1: Carefully desolder the Sample and Hold board from the Main board.
- Step 2: Remove the Sample and Hold board from the Main board taking care not to pull any pads loose.

Replace a Sample and Hold board as follows:

- Step 1: Align the Sample and Hold board square pins with the cleared holes on the Main board. The gap in the line of pins ensures correct mounting.

-
- Step 2: Note the proper orientation, then insert the Sample and Hold board into the receptacle on the Main board.



Do not apply force to any subcomponents on the Sample and Hold board.

- Step 3: Resolder the Sample and Hold board pins to the Main board connections.

Removing/Replacing the Front Panel

See Figures 3-6 and 3-7 for connector and screw locations.

Remove the front panel as follows:

- Step 1: Unhook the return spring, located on the bottom of the 11A16, from the release bar (retain this return spring).
- Step 2: Remove the four Torx head screws (two on the bottom and two on the top of the front panel) that secure the front subpanel to the top and bottom frames.
- Step 3: Pull the release bar out of the 11A16 as far as possible. Leave the release bar in this position.
- Step 4: Insert a slender, sharp tool (such as a scribe) between the subpanel, at the notch around the release bar, and the front panel.
- Step 5: Carefully separate the front panel from the subpanel. (Do not bend the front panel; it is intentionally bowed at the center.)
- Step 6: Remove the front panel from the 11A16.

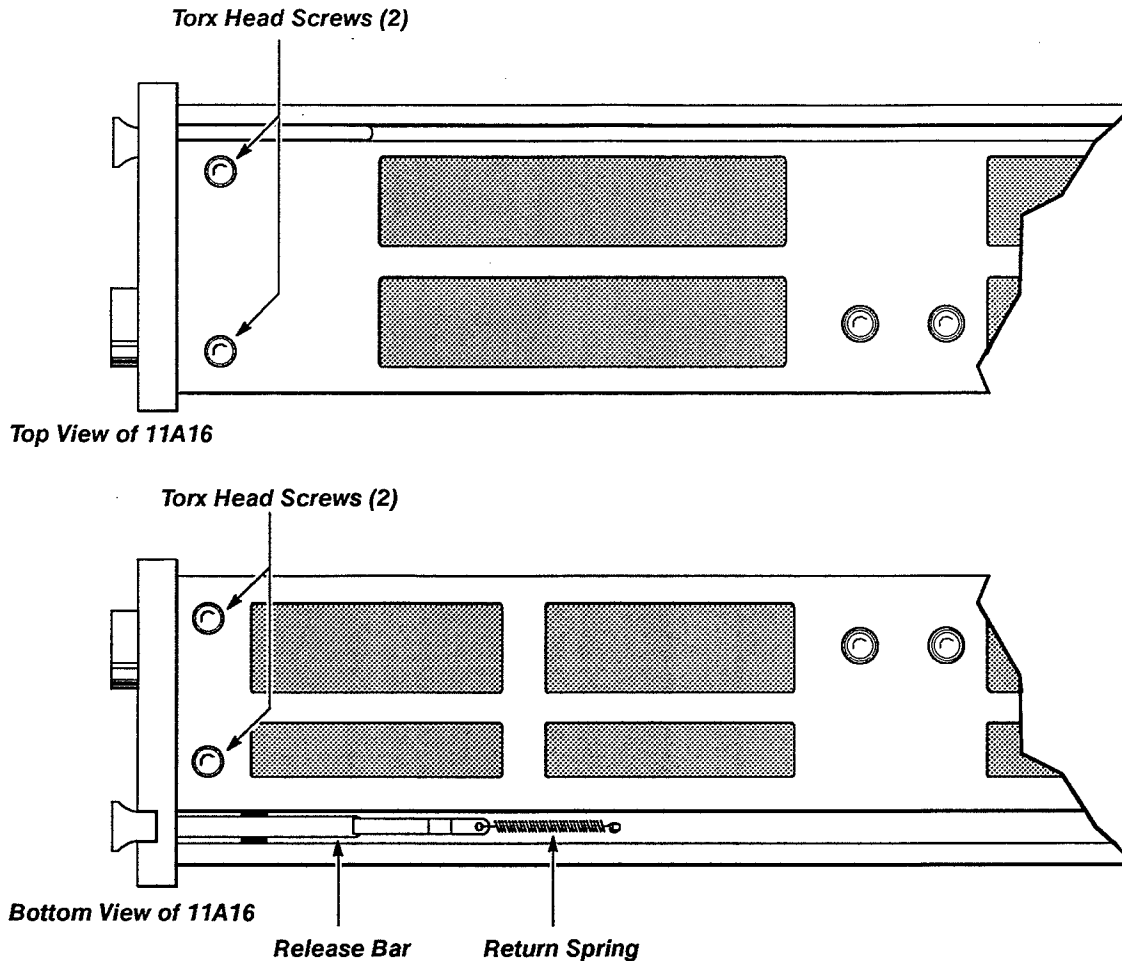

Figure 3-6 – Removing/Replacing the Front Panel Retainer Screws

Replace the front panel as follows:

- Step 1: Ensure that the four screws that secure the front subpanel to the top and bottom frames are removed.
- Step 2: Ensure that the release bar return spring is removed.
- Step 3: Position the 11A16 on its side, with the front panel facing towards you.
- Step 4: Pull the release bar out of the 11A16 as far as possible, and then leave the release bar in this position.
- Step 5: Position the front panel so that the notch in the bottom fits over the release bar rod, then carefully insert the four front-panel tabs into the slots in the front subpanel. (If needed, *carefully* pull the top and bottom frames away from the subpanel to allow the front panel tabs to fit between the casting and the frames. Remove the screws holding the transistor heatsinks to the side rails if more than 1/8" spreading is necessary.)

- Step 6: Carefully press the edges of the front panel into place around the push buttons and the outer edges of the front panel.
- Step 7: Replace the four Torx head screws that secure the front subpanel to the top and bottom frames.
- Step 8: Replace the release bar return spring; orienting the spring so that its loop fits over the frame hook, flat against the frame section.

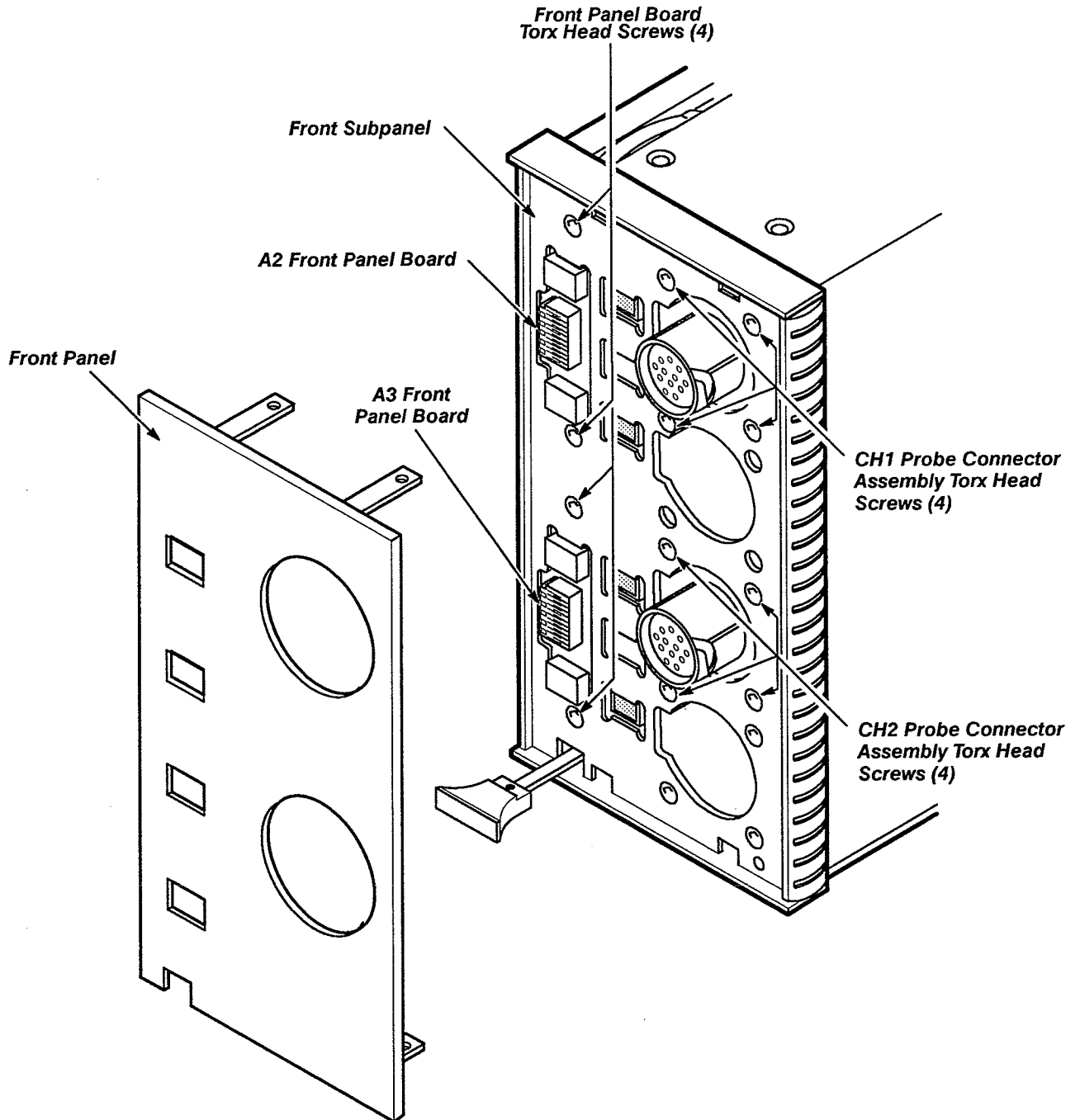

Figure 3-7 – Removing/Replacing the Probe Connectors, Front Panel, and the Front Panel Boards

Removing/Replacing a Front Panel Board

See Figures 3-7, 3-6, and 3-12 for connector, screw, and index locations. A continuity check between the Front Panel and Main board connector will verify a fault.

Remove and replace the Front Panel board as follows:

- Step 1: Disconnect the multi-pin connector that connects from the Front Panel board to the Main board. Note the position of the multi-pin connector index triangle to ensure that this connector can be correctly replaced.
- Step 2: Remove the two Torx head screws that secure the Front Panel board to the front subpanel.
- Step 3: Remove the Front Panel board.

To replace the Front Panel board, perform the previous steps in the reverse order.

Removing/Replacing a Fuse

See Figure 3-2 (FRU locator) for fuse locations. A fuse will usually fail only when a Darlington transistor has failed.

Remove fuses as follows:

- Step 1: Desolder the faulty fuse from the Main board.
- Step 2: Resolder the correct value of fuse to the Main board.
- Step 3: When a fuse is blown, it is likely that one or both Darlington power transistors will be faulty. Troubleshoot these before continuing. The only function of these fuses is to supply current to the Darlington transistors and protect associated circuitry from excessive current flow.

Removing/Replacing the IC Heatsink Bracket

See Figure 3-8 for screw locations. Remove and replace the IC heatsink bracket as follows:

- Step 1: Remove the four Torx head screws that secure the plastic rear panel to the top and bottom frames.
- Step 2: Carefully press the rear-panel lock pin out of the alignment hole in the Main board and remove the plastic rear panel from the 11A16.
- Step 3: Remove the two Torx head screws that secure the heatsink bracket to the Main board.
- Step 4: Remove the four Torx head screws securing the heatsink bracket to the top and bottom frames. Take care not to spread the top and bottom frames which could damage the Darlington Pair power transistors. If necessary, remove the screws securing the transistor heatsink to the side rail.
- Step 5: Slide the heatsink bracket out the rear of the frame. Be careful not to damage the leads of the power transistors.

To replace the heatsink bracket, perform the previous steps in the reverse order.

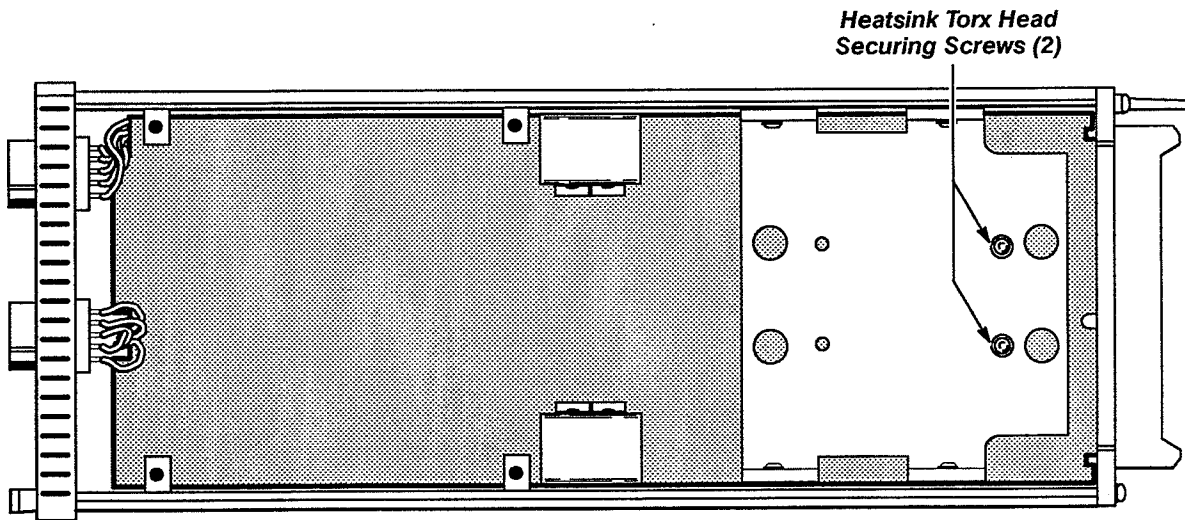
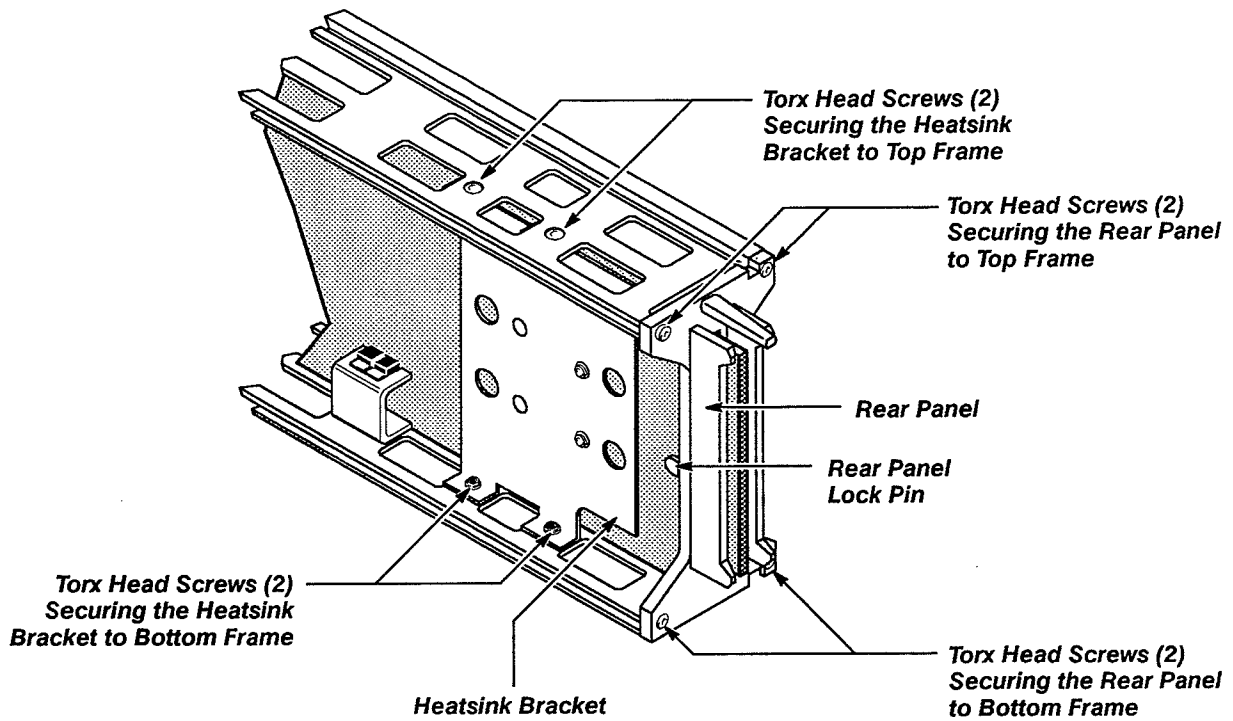
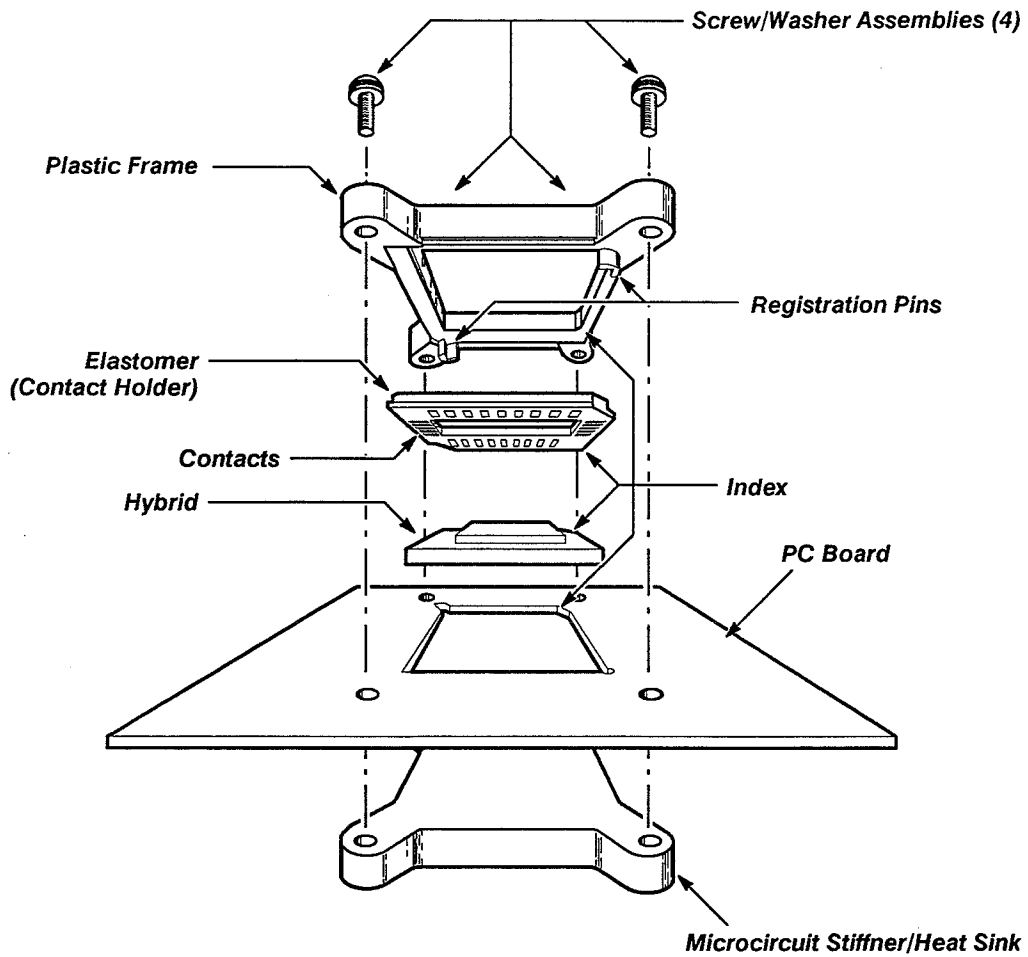

Figure 3-8 — Removing/Replacing the Heatsink Bracket

Removing/Replacing the Hypcon Assembly

The Hypcon (**H**ybrid-**p**rinted circuit **c**onnecto**r**) Assembly connects a hybrid IC to the Main board. A hybrid IC can be an amplifier or other device that has been integrated onto a ceramic substrate. The Hypcon Assembly requires special care. When replacing the Hypcon do not touch the elastomer or hybrid gold-plated contacts with your fingers.

Exploded View of Hypcon Connector



Cross Section View of Hypcon Connector

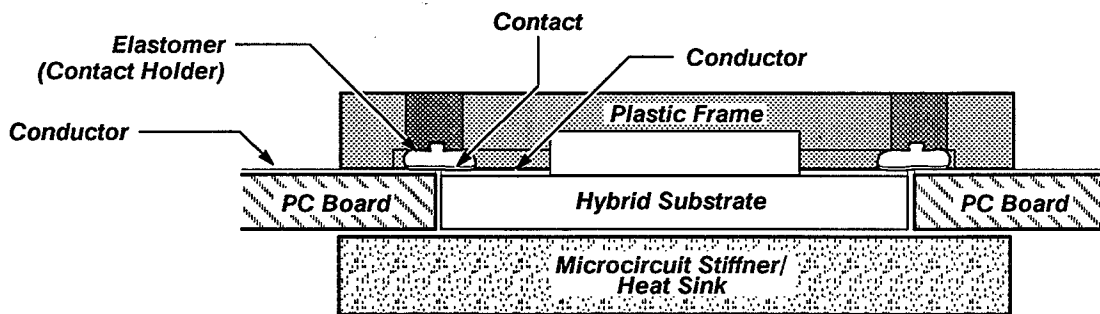

Figure 3-9 – Removing/Replacing the Hypcon Assembly

Note: All work on Hypcon assemblies should be performed in a dust free environment to avoid contamination of contacts.

Remove the Hypcon assembly as follows:

- Step 1: Notice the index on the Main board (arrow) and the plastic frame (pointed tab).
- Step 2: Unscrew and remove the four Torx head screw/washer assemblies.
- Step 3: Lift the plastic frame from the Main board.
- Step 4: Notice the index location of the hybrid, and remove the hybrid from Main board with the tweezers.

Note: *Step 5 describes the removal of the elastomer from the plastic frame. This step is unnecessary when replacing the hybrid only.*

- Step 5: Notice the index location of the elastomer (contact holder). Grasp and lift the corner of the contact holder with the tweezers to remove the holder from the plastic frame.

Replace the Hypcon Assembly as follows:

Before remounting the Hypcon assembly, use a 4X (or greater) magnifying glass to examine the hybrid, elastomer, and the Hypcon contacts for dust, hair, lint, or other foreign matter. If the Main board surfaces require more cleaning, then scrub the surface with a soft rubber eraser and blow on, or vacuum, the surface while dusting it with a small clean brush. If the hybrid and elastomer contact holders are contaminated, then flush or spray the holders with alcohol.



Do not scrub with a cotton-tipped swab or similar device, since cotton fibers may adhere to the contacts.



Special care must be taken to ensure correct index alignment of each Hypcon part while reassembling; since failure to do so can result in a cracked hybrid substrate.

Steps 1–3 are not necessary if you are replacing the hybrid only.

- Step 1: Grasp a corner of the elastomer with the tweezers, and place the elastomer into the plastic frame.
- Step 2: Align the keyed corner of the elastomer with the keyed corner of plastic frame.
- Step 3: Tamp the elastomer into the plastic frame uniformly.

Note: *Keeping the elastomer clean is very important. Small hairs and elastomer flash under the contacts can prevent good electrical contact. Most apparent failures of the hybrid are due to contamination of the Hypcon.*

-
- Step 4: Place the hybrid into the square hole in the Main board. (The hybrid is keyed so that it will fit into the Main board in only one orientation. When the back of the hybrid rests on the heatsink pedestal, the top of the hybrid should be flush with the top of the Main board.)
 - Step 5: Place the plastic frame, with the elastomer installed, over the hybrid so that the key (pointed tab) aligns with the corner arrow on the board.
 - Step 6: Replace the four Torx head screw/washer assemblies, and apply two inch-pounds of torque, (2.3 cm-kg) to secure the connector assembly. Do not overtighten the assembly as this may strip the microcircuit stiffener/heatsink mounting threads.

Removing/Replacing the Main Board

See Figures 3-3, 3-8, 3-10, 3-11, 3-12, and the exploded view in the *Replaceable Parts* section for connector, screw, and index locations. The Darlington transistor pairs including their heatsinks must be saved for use on the new Main board.

Remove the Main board as follows:

- Step 1: Disconnect the multi-pin connectors that connect from the Front Panel boards to the Main board. (Note the position of the multi-pin connector index triangle to ensure proper reassembly.)
- Step 2: Disconnect the 10-pin probe connectors from the Main board. Disconnect the coaxial cables from the Main board and Attenuator boards.
- Step 3: Remove the four screws that secure the Darlington Pair transistor heatsinks to the top and bottom side rails.
- Step 4: Remove the four Torx head screws that secure the plastic rear panel to the top and bottom frames.
- Step 5: Carefully pull the rear-panel lock pin out of the alignment hole in the Main board, and remove the plastic rear panel from the 11A16 (see Fig. 3-8).
- Step 6: Remove the four Torx head screws that secure the hybrid heatsink bracket to the top and bottom frames.
- Step 7: Remove the six Torx head screws and nut blocks that secure the Main board to the top and bottom frames.
- Step 8: Carefully withdraw the Main board between the frames and remove it from the 11A16.
- Step 9: If the Main board is being replaced, remove the Darlington Pair transistors, still mounted on their heatsinks, from the old Main board. Leaving the transistors attached to their heatsink will guarantee proper reinstallation in the new Main board. The transistor sets are interchangeable through the PNP and NPN transistors of a set must be correctly placed. Figure 3-2 shows the correct transistor orientation.

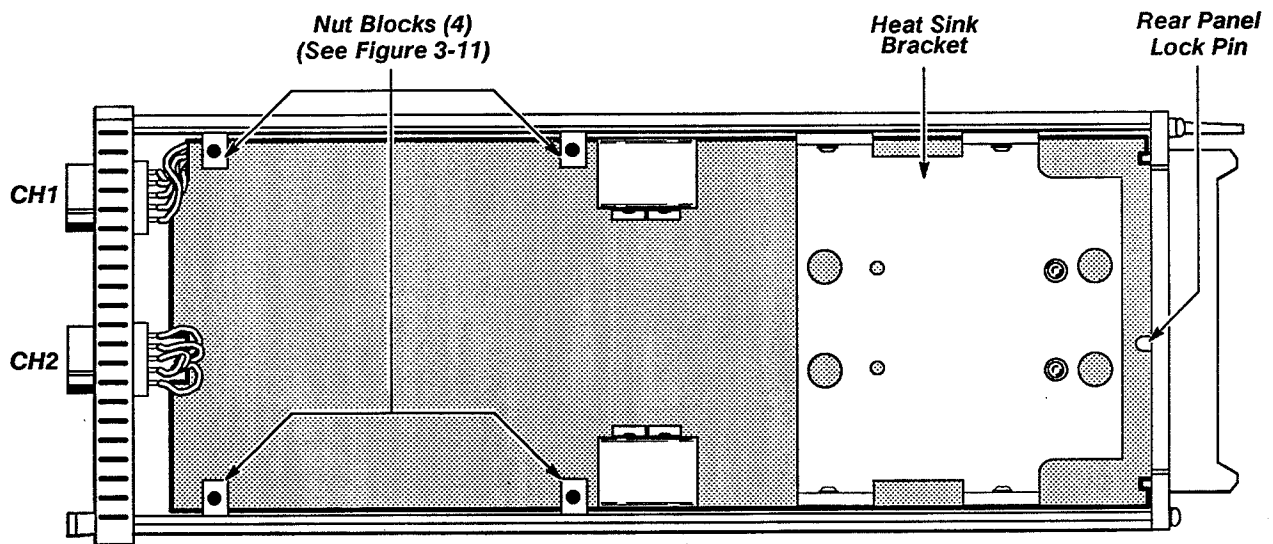
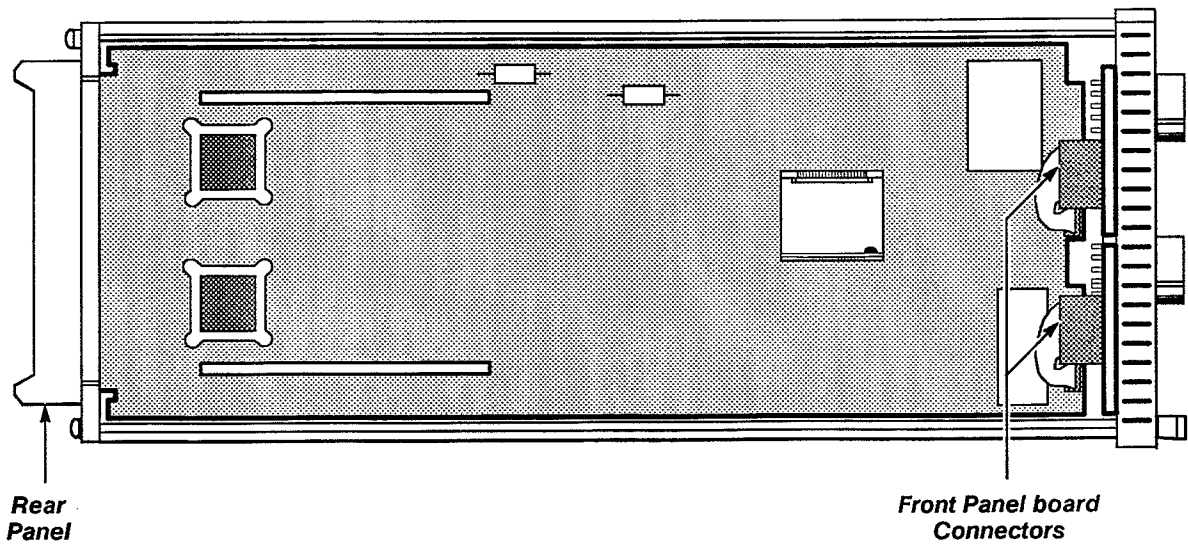

Figure 3-10 — Removing/Replacing the Main Board

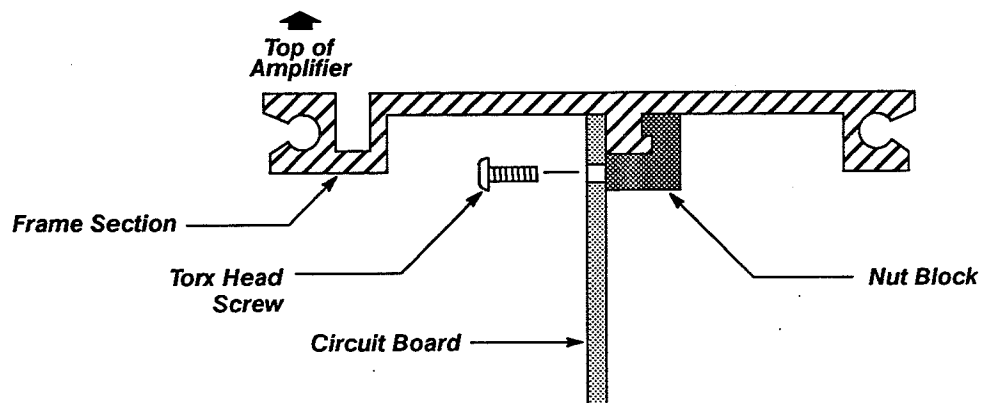

Figure 3-11 — Torx Screw and Nut Block Orientation

If you are replacing a Main board with a new one, you will need to remove two items from the old Main board: the IC Heat Sink bracket and the two pair of Darlington Pair transistors with heatsinks. Replace the Main board as follows:

- Step 1: Lay the 11A16 on its side with the pushbuttons facing upwards. This will allow the Main board to be slid into place, component side up.
- Step 2: Carefully insert the Main board between the frames until the plastic rear panel contacts the top and bottom frames. (The board fits atop the center ridges on the top and bottom frames.)

If you are installing a new Main board, first attach the plastic rear panel, from the old board, to the new Main board. The rear panel helps position the Main board when its rear-panel lock pin is correctly seated in the Main board.

- Step 3: Replace the four Torx head screws that secure the heatsink bracket to the top and bottom frames. The heatsink bracket and the rear panel ensure correct front/back position for the Main board. Refer to Figure 3-8 for screw placement.

If you are installing a new Main board, first mount the large flat heatsink bracket from the old board on the back of the new Main board. Heatsink installation is described on page 3-24.

- Step 4: Replace the four Torx head screws that secure the rear panel to the top and bottom frames.
- Step 5: Replace the six Torx head screws and nut blocks that secure the Main board to the top and bottom frames.
- Step 6: Replace the four screws that secure the Darlington Pair transistor heatsink to the top and bottom rails. If the transistors are already soldered into the Main board, loosen the screws holding the transistors to their heatsinks before attaching the heatsinks to the side rails. This will reduce the likelihood of component damage.

If you are installing a new Main board, first remove the Darlington Pair transistors with their heatsinks from the old board and install them in the new Main board (do not solder yet).

- Step 7: Reconnect the 10-pin probe connectors into their receptacles on the Main board. Connect the probe coaxial cables to the Main board and Attenuator boards.
- Step 8: Reconnect the multi-pin connectors from the Front Panel boards to the connectors on the Main board.
- Step 9: Replace the attenuators (see *Removing/Replacing an Attenuator* in this section).
- Step 10: If the Main board has been replaced, then the Unit Identification (UID) number needs to be re-entered (refer to *Programming the Unit Identification* on page 3-35.)

Removing/Replacing Multi-Pin Connectors

This section describes the multi-pin connectors found on the 11A16. Pin 1 on a multi-pin connector is designated with a triangle (or arrowhead) on the holder. This triangle is indexed to a square pad on the board that denotes pin 1.

A gap between the pin 1 and 3 positions in the holder keys a multi-pin connector. There is a corresponding gap between pins 1 and 3 on the board. (A small plastic plug covers the pin 2 position on the end of the holder.)

Align the plastic plug of the holder with the gap between the board pins (see Fig. 3-12).

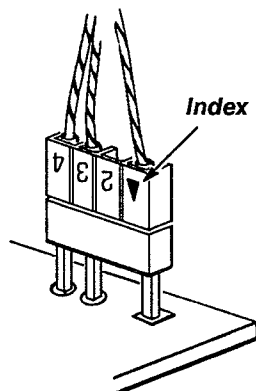

Figure 3-12 — Multi-Pin Connector Orientation

Removing/Replacing a Pin Jumper

Three jumpers, J980, J990, and J992, are installed in the 11A16 for normal operation. See Figure 3-2 for the location and standard configuration of these jumpers.

All jumpers should normally be installed across Pins 2 and 3.

Removing/Replacing a Relay

The relays K1-K4 are located on the Attenuator board. Refer to Figure 3-3. It may be necessary to remove the top side rail to access the pins of a suspect relay. Refer to *Removing/Replacing the Main board* on page 3-28.

Remove a Relay as follows:

- Step 1: Desolder the Relay from the Attenuator board.

Replace a Relay as follows:

- Step 1: Orient pin 1 of the Relay (the end with a white bar) toward the square circuit pad before soldering.

Removing/Replacing a DIP FRU IC

The Main board has several dual-inline-package (DIP) ICs that are replaceable in the field. For Hypcon IC replacement refer to *Removing/Replacing the Hypcon Assembly* earlier in this section.



CAUTION

Observe all the special precautions mentioned under Static-Sensitive Device Classification on page 3-12. Avoid touching the IC or the socket contacts with your fingers as finger oils can lessen reliability.

Do not remove the label affixed to the top of any EPROM. Removing this label will allow light into the IC which may erase data. This also removes critical firmware version information.

If you are required to desolder an IC from the Main board it is suggested that you install a good quality IC socket. A socket saves wear and tear on the Main board when multiple exchanges of an IC are necessary.

See Figures 3-13 and 3-14 for equipment and indexing information.

Remove an FRU IC in a DIP socket as follows:

- Step 1: Use IC insertion-extraction pliers positioned around the outside of the IC. Figure 3-13 shows an example of this type of pliers.
- Step 2: Squeeze the handles to grasp the IC, lightly compressing the pins, and slowly pull the IC from the socket. Place the removed IC on a static free surface or IC holder.



CAUTION

Avoid touching the IC pins or socket contacts with your fingers. Finger oils can lessen contact reliability. Also, touching the pins can induce static-discharge damage should the IC need to be reused.

Replace an FRU IC in a DIP socket as follows:

- Step 1: Place the IC on a static free surface, then grasp the IC with the IC insertion-extraction pliers; ensuring that all the pins of the IC are straight and lightly compressed. Do not use the IC label as an index, instead locate the index on the body of the IC.
- Step 2: Align the IC index slot with that of the socket. (Fig. 3-14 gives an illustration of this indexing.)
- Step 3: Align the pins with their respective socket contacts.
- Step 4: Press the IC slowly and evenly into its socket. Ensure that the IC is firmly seated in its socket.

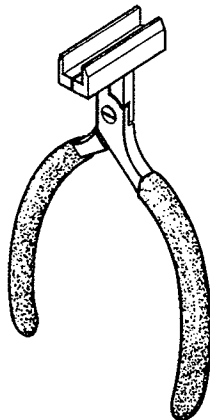

Figure 3-13 – IC Insertion-Extraction Pliers

Removing/Replacing a “Slam-Pack” IC

A Slam-Pack IC is indexed to its socket by a beveled corner. The other corners are notched to fit the edges of the socket. The beveled corner aligns with a spring (small metal tab) at one corner of the socket.

Remove the Slam-Pack IC as follows:

- Step 1: To remove the retaining clip, hold the heatsink cover in place and move the retaining clip off the tabs while pushing down slightly on the cover.
- Step 2: Slowly remove the cover to prevent the IC from falling out. (Note the position of the index on the IC to ensure that this IC can be correctly replaced.)
- Step 3: Remove the IC with tweezers.



Avoid touching the IC or the socket contacts with your fingers. Finger oils can lessen reliability.

Replace the Slam-Pack IC as follows:

- Step 1: Using tweezers, place the beveled corner of the replacement IC against the index spring.



Do not damage the spring with the beveled corner; this could cause a short in the two corner contacts.

- Step 2: Using the tweezers, arrange the other corners of the IC to fit evenly at the socket edges.
- Step 3: Set the cover flat on the IC with the cover end tabs aligned with the mating recesses of the socket. Be sure the end tabs are not inserted yet.
- Step 4: Push the cover down, keeping the cover flat on the IC, and slide the cover end tabs into place. Hold the cover then move the retaining clip over the tabs on the other end of the cover.

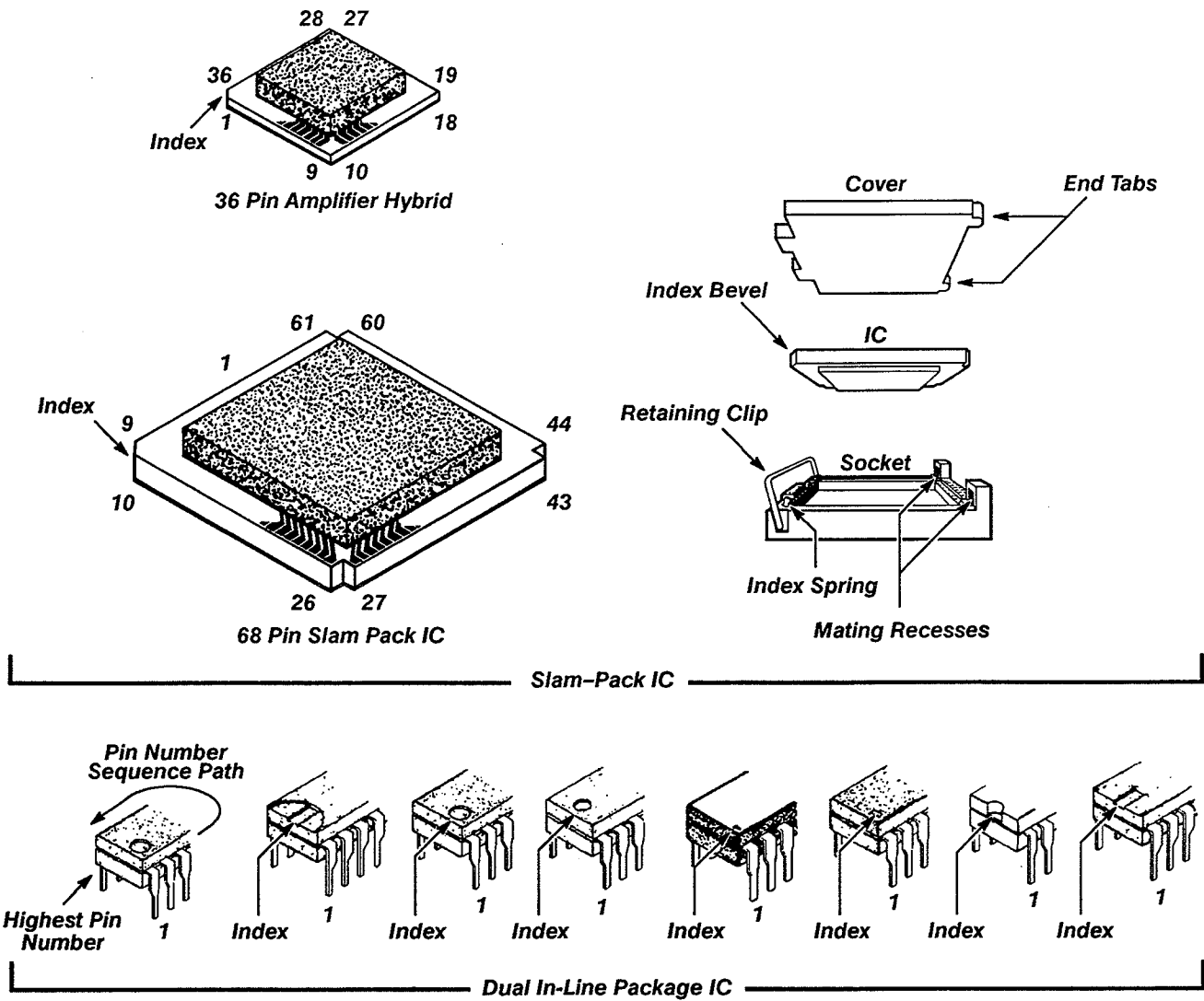

Figure 3-14 — Semiconductor Indexing Diagram

Programming the Unit Identification

This section discusses the procedure to enter the Unit Identification (UID) into the 11A16 nonvolatile RAM (NVRAM). The UID is identical to the serial number of the 11A16, and is stored in NVRAM. You will need to enter this number if the Main board is replaced or if data in NVRAM becomes corrupted.

Enter the UID as follows:

- Step 1: Connect your terminal to the RS-232-C port of the mainframe. (Refer to the *User Reference* manual of your mainframe for instructions on setting up the RS-232-C parameters.)
- Step 2: Configure the mainframe jumper that allows programming of calibration constants and the mainframe Unit Identification (often referred to as the Cal Lock jumper). Refer to the mainframe *Service Reference* for instructions on locating and setting the Cal Lock jumper.
- Step 3: Move the jumper J990 on the Main board so that it covers the two left-most jumper pins (pins 1-2). Refer to Figure 3-2 for the location of this jumper. Obtain the 11A16 serial number from the printed tag on the 11A16 rail near the Front Panel.
- Step 4: Install the 11A16 in any compartment.
- Step 5: Set the ON/STANDBY switch to ON.
- Step 6: Wait until the diagnostic tests are completed.
- Step 7: On your terminal, type the command:
UID [Left|Center|Right]:“< Serial Number >”
Left|Center|Right refers to the compartment that the 11A16 resides.
- Step 8: On the terminal, type the query:
UID? [Left|Center|Right]
Observe that the correct UID is reported.
- Step 9: Set the ON/STANDBY switch to STANDBY.
- Step 10: Remove the 11A16.
- Step 11: Return the jumper J990 on the Main board to its normal operating position (across pins 2-3). Reset the mainframe Cal Lock jumper to its normal position.

You can use this procedure to confirm the UID by repeating all steps except Step 6.

Replaceable Parts

This section contains a list of the components that are replaceable for the 11A16 Two-Channel Amplifier. As described below, use this list to identify and order replacement parts.

Parts Ordering Information

Replacement parts are available from or through your local Tektronix, Inc. service center or representative.

Changes to Tektronix instruments are sometimes made to accommodate improved components as they become available and to give you the benefit of the latest circuit improvements. Therefore, when ordering parts, it is important to include the following information in your order:

- Part Number
- Instrument Type or Model Number
- Instrument Serial Number
- Instrument Modification Number, if applicable

If a part you order has been replaced with a different or improved part, your local Tektronix service center or representative will contact you concerning any change in the part number.

Change information, if any, is located at the rear of this manual.

Module Replacement

The 11A16 Two-Channel Amplifier is serviced by module replacement so there are three options you should consider:

Module Exchange—In some cases you may exchange your module for a remanufactured module. These modules cost significantly less than new modules and meet the same factory specifications. For more information about the module exchange program, call 1-800-TEKWIDE, extension BV 5799.

Module Repair—You may ship your module to us for repair, after which we will return it to you.

New Modules—You may purchase new replacement modules in the same way as other replacement parts.

Using the Replaceable Parts List

The tabular information in the Replaceable Parts List is arranged for quick retrieval. Understanding the structure and features of the list will help you find the all the information you need for ordering replacement parts.

Item Names

In the Replaceable Parts List, an Item Name is separated from the description by a colon (:). Because of space limitations, an Item Name may sometimes appear as incomplete. For further Item Name identification, U.S. Federal Cataloging Handbook H6-1 can be used where possible.

Indentation System

This parts list is indented to show the relationship between items. The following example is of the indentation system used in the Description column:

1	2	3	4	5	<i>Name & Description</i>
					<i>Assembly and/or Component</i>
					<i>Attaching parts for Assembly and/or Component</i> <i>(END ATTACHING PARTS)</i>
					<i>Detail Part of Assembly and/or Component</i>
					<i>Attaching parts for Detail Part</i> <i>(END ATTACHING PARTS)</i>
					<i>Parts of Detail Part</i>
					<i>Attaching parts for Parts of Detail Part</i> <i>(END ATTACHING PARTS)</i>

Attaching Parts always appear in the same indentation as the item it mounts, while the detail parts are indented to the right. Indented items are part of, and included with, the next higher indentation. Attaching parts must be purchased separately, unless otherwise specified.

Abbreviations

Abbreviations for the FRU boards listed in Table 5-1 conform to American National Standards Institute (ANSI) standard Y1.1. Other FRUs are listed on page NO TAG.

Table 5-1 – Board FRUs

FRU	Part Number	Description
A1	671-1448-00	Main Board
A1A1	670-8986-00	Sample/Hold Board
A1A2	670-8986-00	Sample/Hold Board
A1A3	671-1451-01	Attenuator Board
A1A4	671-1451-01	Attenuator Board
A2	670-9336-00	Front Panel Board
A3	670-9336-00	Front Panel Board

CROSS INDEX - MFR. CODE NUMBER TO MANUFACTURER

Mfr. Code	Manufacturer	Address	City, State, Zip Code
TK0435	LEWIS SCREW CO	4300 S RACINE AVE	CHICAGO IL 60609-3320
TK0860	LABEL GRAPHICS	6700 SW BRADBURY CT	PORTLAND OR 97224
TK1163	POLYCAST INC	9898 SW TIGARD ST	TIGARD OR 97223
TK1326	NORTHWEST FOURSLIDE INC	18224 SW 100TH CT	TUALATIN OR 97062
TK1465	BEAVERTON PARTS MFG CO	1800 NW 216TH AVE	HILLSBORO OR 97124-6629
TK1572	RAN-ROB INC	631 85TH AVE	OAKLAND CA 94621-1254
TK1689	AROMAT CORP	10400 N TANTAU AVE	CUPERTINO CA 95014-0708
TK1943	NEILSEN MANUFACTURING INC	3501 PORTLAND ROAD NE	SALEM OR 97303
TK1967	SYNDETEK	3915 E MAIN	SPOKANE WA 99202
0JR05	TRIQUEST CORP	3000 LEWIS AND CLARK HWY	VANCOUVER WA 98661-2999
0KB01	STAUFFER SUPPLY	810 SE SHERMAN	PORTLAND OR 97214
0KB05	NORTH STAR NAMEPLATE	1281-S NE 25TH	HILLSBORO OR 97124
03888	KDI ELECTRONICS	60 S JEFFERSON RD	WHIPPANY NJ 07981-1001
04713	MOTOROLA INC SEMICONDUCTOR PRODUCTS SECTOR	5005 E MCDOWELL RD	PHOENIX AZ 85008-4229
12327	FREEWAY CORP	9301 ALLEN DR	CLEVELAND OH 44125-4632
2K262	BOYD CORP	6136 NE 87th AVE PO BOX 20038	PORTLAND OR 97220
22526	DU PONT E I DE NEMOURS AND CO INC DU PONT ELECTRONICS DEPT	515 FISHING CREEK RD	NEW CUMBERLAND PA 17070-3007
22599	AMERACE CORP ESNA DIV	15201 BURBANK BLVD SUITE C	VAN NUYS CA 91411-3532
5Y400	TRIAx METAL PRODUCTS INC DIV OF BEAVERTON PARTS MFG CO	1800 216TH AVE NW	HILLSBORO OR 97124-6629
66302	VLSI TECHNOLOGY INC	1109 MCKAY DR	SAN JOSE CA 95131-1706
71400	BUSSMANN DIV OF COOPER INDUSTRIES INC	114 OLD STATE RD PO BOX 14460	ST LOUIS MO 63178
73743	FISCHER SPECIAL MFG CO	111 INDUSTRIAL RD	COLD SPRING KY 41076-9749
8X345	NORTHWEST SPRING & MFG CO	5858 WILLOW LANE	LAKE OSWEGO OR 97034-5343
80009	TEKTRONIX INC	14150 SW KARL BRAUN DR PO BOX 500	BEAVERTON OR 97077-0001
83385	MICRODOT MFG INC GREER-CENTRAL DIV	3221 W BIG BEAVER RD	TROY MI 48098
83486	ELCO INDUSTRIES INC	1101 SAMUELSON RD	ROCKFORD IL 61101
92101	SCHULZE MFG	50 INGOLD RD	BURLINGAME CA 94010-2206
93907	TEXTRON INC CAMCAR DIV	600 18TH AVE	ROCKFORD IL 61108-5181

Fig. & Index No.	Tektronix Part No.	Serial No.		Qty	12345 Name & Description	Mfr. Code	Mfr. Part No.
		Effective	Dscont				
1-1	366-0600-00			4	PUSH BUTTON:0.269 X 0.409,ABS	TK1163	ORDER BY DESC
-2	366-1058-00			1	KNOB:GRAY,0.625 X 0.255 X 0.485 (ATTACHING PARTS)	0JR05	ORDER BY DESC
-3	214-1095-00			1	PIN,SPRING:0.187 L X 0.094 OD,STL (END ATTACHING PARTS)	22599	52-022-094-0187
-4	105-0076-04			1	RELEASE BAR,LCH:PLUG-IN UNIT	0JR05	ORDER BY DESC
-5	214-1280-00			1	SPRING,HLCPS:0.14 OD X 1.126 L,TWIST LOOP	8X345	ORDER BY DESC
-6	214-1054-00			1	SPRING,FLAT:0.825 X 0.322,SST	TK1326	ORDER BY DESC
-7	105-0075-00			1	BOLT,LATCH:7A & 7B SER PL-IN	80009	105007500
-8	333-3790-00			1	PANEL,FRONT:11A16 (ATTACHING PARTS)	0KB05	ORDER BY DESC
-9	211-0392-00			4	SCREW,MACHINE:4-40 X 0.25,FLH,STL,T-8 (END ATTACHING PARTS)	93907	ORDER BY DESC
-10	348-0235-00			1	SHLD GSKT,ELEK:FINGER TYPE,4.734 L,	92101	ORDER BY DESC
-11	386-5219-00			1	SUBPANEL,FRONT:11A44	TK1465	ORDER BY DESC
-12	670-9336-00			2	CIRCUIT BD ASSY:FRONT PANEL (SEE A2,A3, EXCHANGE ITEM)	80009	670933600
-13	610-0777-00			2	CONNECTOR ASSY:11A16 (A1J1001,A1J1002) (ATTACHING PARTS)	80009	610077700
-14	210-0405-00			2	NUT,PLAIN,HEX:2-56 X 0.188,BRS	73743	12157-50
-15	211-0413-00			12	SCREW,MACHINE:2-56 X 0.375,FLH,82 DEG,STL (END ATTACHING PARTS)	93907	221-00995-024
-16	210-0259-00			2	TERMINAL,LUG:0.099 ID,LOCKING,BRS	TK1572	ORDER BY DESC
-17	386-6023-00			1	PLATE,CONN MT:ALUMINUM	TK1943	ORDER BY DESC
-18	174-0159-00			2	CA ASSY,SPELEC:6.26 AWG,3.0 L,RIBBON (A1J1040,A1J1080)	TK1967	ORDER BY DESC
-19	426-2061-00			1	FR SECT,PLUG-IN:LOWER,ALUMINUM	TK1465	ORDER BY DESC
-20	211-0392-00			2	SCREW,MACHINE:4-40 X 0.25,FLH,STL,T-8 (END ATTACHING PARTS)	93907	ORDER BY DESC
-21	334-3540-00			1	MARKER,IDENT:MARKED WARNING	TK0860	ORDER BY DESC
-22	151-0391-00			2	TRANSISTOR:DARLINGTON,PNP,SI (A1Q601,A1Q691)	04713	MPS-U95
	342-0937-00			4	INSULATOR,XSTR:BERGQUIST SIL-PA K-10	2K262	ORDER BY DESC
-23	151-0390-00			2	TRANSISTOR:DARLINGTON,NPN,SI (A1Q600,A1Q690) (ATTACHING PARTS)	04713	MPS-U45
-24	211-0022-00			4	SCREW,MACHINE:2-56 X 0.188,PNH,STL	TK0435	ORDER BY DESC
-25	210-1156-00			4	WASHER,SHLDR:0.09 ID X 0.2 OD X 0.085 D,NYL	80009	210115600
-26	210-0994-00			4	WASHER,FLAT:0.125 ID X 0.25 OD X 0.022,STL (END ATTACHING PARTS)	12327	ORDER BY DESC
-27	407-3676-00			1	BRACKET,HT SK:ALUMINUM (ATTACHING PARTS)	5Y400	ORDER BY DESC
-28	211-0392-00			4	SCREW,MACHINE:4-40 X 0.25,FLH,STL,T-8 (END ATTACHING PARTS)	93907	ORDER BY DESC
-29	407-3363-00			1	BRACKET,HEAT SK:ALUMINUM (ATTACHING PARTS)	TK1943	ORDER BY DESC

Fig. & Index No.	Tektronix Part No.	Serial No.		Qty	12345 Name & Description	Mfr. Code	Mfr. Part No.
		Effective	Dscont				
-30	211-0711-00			2	SCR,ASSEM WSHR:6-32 X 0.25,PNH,STL,T15 (END ATTACHING PARTS)	0KB01	ORDER BY DESC
-31	671-1448-00			1	CIRCUIT BD ASSY:MAIN (SEE A1, EXCHANGE ITEM)	80009	671144800
-32	165-2089-06			2	MICROCKT,LINEAR:VERT PREAMP,200 OHM	80009	165208906
-33	214-3785-00			2	HEAT SINK,ELEC:ALUMINUM (ATTACHING PARTS)	80009	ORDER BY DESC
-34	211-0391-00			8	SCREW,MACHINE:2-56 X 0.437,P4,STL,T-8 (END ATTACHING PARTS)	83486	ORDER BY DESC
-35	156-2625-00			1	MICROCKT,DGTL:NMOS,CUSTOM,SENES (A1U850)	66302	VF4124RC CC0001
-36	670-8986-00			2	CIRCUIT BD ASSY:SAMPLE/HOLD (SEE A1A1,A1A2, EXCHANGE ITEM)	80009	670898600
-37	131-0993-00			3	BUS,CONDUCTOR:SHUNT/SHORTING (A1J980,A1J990,A1J992)	22526	65474-006
-38	159-0235-00			2	FUSE,WIRE LEAD:0.75A,125V,FAST (A1F500,A1F610)	71400	TR/MCR 3/4
-39	160-6636-00			1	MICROCKT,DGTL:CMOS,16 X8 EPROM,PRGM (A1U1080)	80009	160663600
-40	671-1451-00	B010100	B010154	2	CIRCUIT BD ASSY:ATTENUATOR	80009	671145100
	671-1451-01	B010155		2	CIRCUIT BD ASSY:ATTENUATOR; (SEE A1A3,A1A4, EXCHANGE ITEM)	80009	671145101
-41	148-0246-00			8	RELAY,ARM:2 FORM C 2 COIL LATCH, 5V (K1,K2,K3,K4 ON BOTH A1A3,A1A4)	TK1689	TQ2EH-L2-5V
-42	220-0022-00			6	NUT BLOCK:0.4 X 0.25 X 0.33,4-40 THRU,NI (ATTACHING PARTS)	80009	220002200
-43	211-0409-00			6	SCR,ASSEM WSHR:4-40 X 0.312,PNH,STL,T10 (END ATTACHING PARTS)	93907	829-06888-024
-44	426-2060-00			1	FR SECT,PLUG-IN:UPPER,ALUMINUMN (ATTACHING PARTS)	TK1465	ORDER BY DESC
-45	211-0392-00			2	SCREW,MACHINE:4-40 X 0.25,FLH,STL,T-8 (END ATTACHING PARTS)	93907	ORDER BY DESC
-46	334-3438-00			1	MARKER,IDENT:MARKED TURN OFF POWER	TK0860	ORDER BY DESC
-47	214-1061-00			1	CONTACT,ELEC:GROUNDING,CU BE	80009	214106100
-48	337-1064-11			2	SHIELD,ELEC:PLUG-IN SIDE,	80009	ORDER BY DESC
-49	386-5296-00			1	PANEL,REAR:POLYCARBONATE (ATTACHING PARTS)	TK1163	ORDER BY DESC
-50	213-0904-00			4	SCREW,TPG,TR:6-32 X 0.5,PNH,STL (END ATTACHING PARTS)	83385	ORDER BY DESC
STANDARD ACCESSORIES							
	015-0598-00			1	VOLTAGE ADPTR:11A16	80009	015059800
	015-0601-00			1	ADAPTER:1 TURN CURRENT LOOP	03888	P/N VNPRT:JA-11
	070-7763-00			1	MANUAL,TECH:USERS REFERENCE,11A16	80009	070776300
	070-7764-00			1	MANUAL,TECH:SERVICE REFERENCE,11A16	80009	070776400

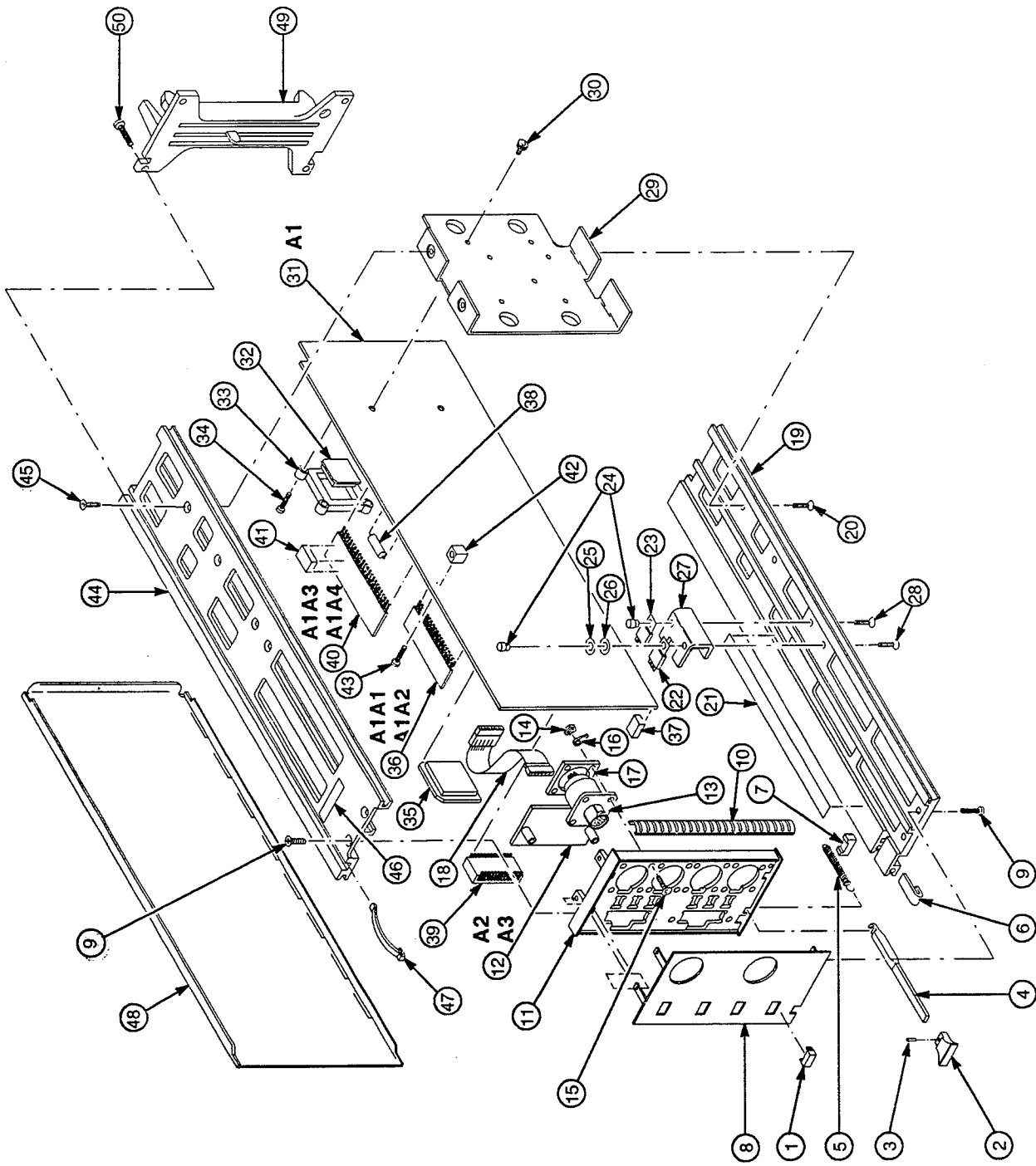

Figure 5-1 — Exploded View of the 11A16 Two Channel Current Amplifier