**Instruction
Manual**

2532

**2532
Digital Power Meter**

IM 2532 - 04E

INTRODUCTION

Thank you for purchasing the YOKOGAWA Model 2532 Digital Power Meter.

Model 2532 Digital Power Meter consolidates the high-speed precision instrument design knowhow accumulated by YOKOGAWA over the years into a power meter with wide bandwidth, various functions and high accuracy to meet a variety of customer needs.

In order to take full advantage of all of the functions of Model 2532 Digital Power Meter, and to use it correctly and efficiently, please read this manual completely to become familiar with its functions and operation before use.

NOTES

- Model 2532 is a measuring instrument for mixed AC/DC signals. It can also be used with signals that contain only an AC component or only a DC component. However, if both AC and DC components are present then it is their sum that is measured. It is not possible to separate the AC and DC components for measurement and display.
- The reactive power (var), apparent power (VA), power factor (PF), and phase angle (deg) measurements of this instrument are derived from the voltage (V), current (A), and active power (W) measurements by digital computation. In the case of non-sinusoidal input waveforms, differences may therefore arise between the measurement results of Model 2532 and instruments employing different measurement principles.
- Every effort to ensure accuracy has been made in the preparation of this manual. However, if you should notice any errors or omissions, please contact your dealer or YOKOGAWA representative.
- The contents of this manual are subject to change without prior notice.

WARNING

- **Power Supply**
Ensure the source voltage matches the voltage of the power supply before turning ON the power.
- **Power Cord and Plug**
To prevent an electric shock or a fire, be sure to use power supply cord and 3 to 2 pin adapter supplied by YOKOGAWA. Main power plug must be plugged in an outlet with protective grounding terminal only. Do not invalidate protection by using an extension cord without protective grounding.
- **Protective Grounding**
Make sure to connect the protective grounding to prevent from an electric shock before turning on the power.
- **Necessity of Protective Grounding**
Never cut off the internal or external protective grounding wire or disconnect the wiring of the protective grounding terminal. Doing so poses a potential shock hazard.
- **Fuse**
To prevent a fire, make sure to use the fuse with specified standard (current, voltage, type). Before replacing the fuse, turn off the power and unplug the power cord. Do not use a different fuse or short-circuit the fuse holder.
- **Do not Operate in an Explosive Atmosphere**
Do not operate the instrument in the presence of flammable liquids or vapors. Operation of any electrical instrument in such an environment constitutes a safety hazard.
- **Do Not Remove Any Covers**
There are some areas with high voltage. Do not remove the cover if the power supply is connected. The cover should be removed by qualified personnel only.
- **External Connection**
To ground securely, insert the main power plug before connecting to measurement or control units.
- In the event of any of the following, contact YOKOGAWA. Addresses may be found on the back cover of this manual.
The instrument does not operate normally, requiring repair.

WARNUNG

- **Netzteil**

Vergewissern Sie sich, daß die lokale Netzspannung gleich der angegebenen Betriebsspannung des Geräts ist, bevor Sie das Gerät an die Netzspannung anschließen und einschalten.

- **Netzleitung und Stecker**

Um elektrische Schläge oder Feuer zu verhindern, verwenden Sie ausschließlich das von YOKOGAWA gelieferte Netzkabel.

Verwenden Sie nur Verlängerungskabel, die mit einem Schutzleiter versehen sind.

- **Schutzerde**

Für dieses Instrument wird ein 3-adriges Netzkabel mit Erdleiter verwendet.

- **Sicherung**

Um die Entstehung von Feuer zu verhindern, dürfen nur Sicherungen mit den angegebenen Kennwerten eingesetzt werden (d. h. Strom, Spannung und Typ). Vor dem Austausch der Sicherung muß das Instrument ausgeschaltet werden, weiterhin muß der Netzstecker aus der Steckdose herausgezogen werden. Verwenden Sie keine Sicherungen mit anderen als den angegebenen Kennwerten. Insbesondere darf die Sicherung nicht durch eine Kurzschlußstrecke (z. B. Drahtbrücke) ersetzt werden.

- **Instrument nicht in explosiven Atmosphären betreiben**

Betreiben Sie das Instrument nicht in der Gegenwart von brennbaren Flüssigkeiten, Dämpfen oder Gasen. Der Betrieb elektrischer Geräte in derartigen Umgebungen bildet eine Gefahr.

- **Nehmen Sie keine Abdeckungen ab**

In einigen Bereichen des Instruments liegen Hochspannungen an. Nehmen Sie keine Abdeckungen ab, sondern lassen Sie derartige Arbeiten durch einen Servicetechniker ausführen.

- **Externe Anschlüsse**

Um eine sichere Erdung zu gewährleisten, stecken Sie den Netzstecker in eine geeignete Steckdose ein, bevor Sie das Gerät an Meßobjekte oder Steuerungseinheiten anschließen.

- **Wartung**

Wenn das Instrument nicht wie normalerweise funktioniert, und eine Reparatur notwendig ist, benachrichtigen Sie bitte YOKOGAWA oder einen YOKOGAWA-Verkaufsrepräsentanten.

AVERTISSEMENT

- **Alimentation**

Vérifier que la tension de l'alimentation est bien la tension requise par l'appareil.

- **Câble d'alimentation et prise**

Afin d'empêcher un choc électrique ou un incendie, utiliser le câble et l'adaptateur à deux ou trois broches fourni par YOKOGAWA. La prise d'alimentation ne doit être branchée que sur une sortie équipée d'une prise de terre.

Ne pas utiliser de rallonge qui ne serait pas équipée de mise à la terre.

- **Mise à la terre**

La vérifier avant de mettre l'appareil sous tension. Si on utilise un adaptateur à deux ou trois broches, introduire la broche de terre de l'adaptateur dans la sortie de terre.

- **Nécessité absolue de la mise à la terre**

Ne jamais sectionner le câble de mise à la terre, qu'il soit interne ou externe, ne jamais le déconnecter.

- **Fusible**

S'assurer que le type de fusible utilisé est le bon (courant, tension, type).

Avant de remplacer un fusible, mettre l'appareil sous tension et enlever la prise.

- **Ne pas utiliser l'appareil en atmosphère déflagrante**

Ne pas faire fonctionner l'appareil à proximité de liquides ou de vapeurs inflammables.

- **Ne pas enlever la protection**

Dans les zones à haute tension, ne pas enlever de boîtier. Seul notre agent est habilité à le faire.

- **Raccord externe**

Pour effectuer une mise à la terre en toute sécurité, raccorder d'abord à la prise d'alimentation secteur avant de raccorder au circuit de mesure ou de contrôle.

- **Maintenance**

Lorsque cet appareil ne fonctionne pas normalement, ou doit être réparé, prenez contact avec YOKOGAWA.

 **WARNUNG**

Seite 3 - 3

- ◎ Um elektrische Schläge oder Feuer zu verhindern, verwenden Sie ausschließlich das vor YOKOGAWA gelieferte Netzkabel. Verwenden Sie nur Verlängerungskabel, die mit einem Schutzleiter versehen sind.
- ◎ Immer den Strom der zu messenden Leitung ausschalten, bevor diese Leitung am Meßgerät angeschlossen wird. Sicherstellen, daß der Spannungsschaltkreis nicht an der Strom-Eingangsklemme angeschlossen wird. Der Stromschaltkreis darf ebenso nicht an die Spannungs-Eingangsklemme angeschlossen werden. Bei Nichtbeachten dieser Maßnahme kann nicht nur das Meßgerät durchbrennen, sondern es kann auch Gefahren für das Personal hervorrufen.
- ◎ Die Eingangsklemme, an der die zu messende Leitung angeschlossen ist, führt gefährliche Hochspannung. Unbedingt jeden unnötigen Kontakt mit der Klemme vermeiden.
- ◎ Es ist äußerst gefährlich, Kabel anzuschließen oder abzutrennen, wenn die anzuschließende oder abzutrennende Leitung unter Spannung steht. Beim Anschließen oder Abtrennen der Kabel muß deshalb die zu messende Leitung vom Strom abgetrennt werden.
- ◎ Wenn eine Eingangsspannung an das Meßgerät angelegt wird, dessen maximal zulässige Augenblicksleistung oder Dauerleistung (in Abschnitt 1.5 "Spezifikationen" spezifiziert) überschreitet, kann nicht nur Schaden am Meßgerät entstehen, sondern auch können Gefahren für das Bedienungspersonal hervorgerufen werden. Egal ist ob das Meßgerät unter Spannung steht oder nicht.
- ◎ Für den Anschluß, Kabel verwenden die:
 - ausreichenden Nennwerten haben für Stehspannung und Stromkapazität (z. B. max. Nennwerte von 600 V bei 5 A und einem Leiterquerschnitt von 0.86 mm²) und
 - einen dementsprechenden Isolationswiderstand haben.
- ◎ Die blanke Drahtstelle des anzuschließenden Kabels soll derjenige Länge sein, daß nach dem Anschließen keine blanke Drahtstelle mehr sichtbar ist.

 **WARNING**

Page 3 - 8

- ⊙ NEVER open the secondary circuit of an external current transformer circuit, or in any way allow it to become open, when power is applied to its primary. Opening the circuit will result in extremely high and dangerous voltages being generated across the current transformer secondary winding.
- ⊙ For safety, use the external PT and CT which are doubly isolated.

 **WARNUNG**

Seite 3 - 8

- ⊙ NIEMALS den Sekundärschaltkreis einer externen Stromtransformatorschaltung öffnen oder das Öffnen in irgendeiner Weise zulassen, wenn dem Primärschaltkreis Leistung zugeführt wird. Durch Öffnen des Schaltkreises kommt es zu extrem hohen und gefährlichen Spannungen, die sich über die gesamte Sekundärwicklung des Stromtransformators verteilen.
- ⊙ Aus Sicherheitsgründen den doppelt isolierten externen PT und CT verwenden.

 **AVERTISSEMENT**

Page 3 - 8

- ⊙ NE JAMAIS ouvrir, et ne jamais laisser s'ouvrir, le circuit secondaire d'un transformateur d'intensité externe lorsque son circuit primaire est alimenté. L'ouverture du circuit provoquerait l'application d'une tension extrêmement élevée aux enroulements secondaires du transformateur d'intensité.
- ⊙ Pour des raisons de sécurité, utiliser un transformateur de puissance (PT) et un transformateur d'intensité (CT) à double isolement.

 **AVERTISSEMENT**

Page 3 - 10

- ⊙ Le numéro de produit YOKOGAWA du câble d'entrée parallèle est B9292WD (accessoire).
La tension d'entrée nominale du câble est 300 V (capable de supporter une tension de 1500 V). Ne pas dépasser cette tension pendant l'utilisation. Le faire pourrait provoquer des erreurs et présenter un danger pour le personnel.
- ⊙ Toujours mettre la SOURCE hors tension avant de procéder à un raccordement en cas d'utilisation d'un circuit parallèle externe, du fait qu'il est dangereux de procéder à des raccordements lorsqu'un circuit est sous tension.
La même mesure de précaution doit être prise vis à vis des bornes d'entrée et des bornes de sortie parallèles (OUT H et OUT L) du fait qu'elles peuvent également être sous haute tension.
- ⊙ Le circuit parallèle peut être sous haute tension.
NE JAMAIS toucher au circuit parallèle lorsqu'il est sous tension.

Power cord	<p>Never place any heavy object on the power cord. Never let the cord touch any heating device. Damage to the cord may result in electrical shock or fire.</p> <p>If the cord is damaged, contact the source from which the instrument was purchased. The part numbers of the power cards for the various international standards are given in Table 1.2.</p>
Operating Environment	<p>To prevent excessive internal temperature rise, be careful not to place the instrument in a poorly ventilated area.</p> <p>Also, do not place the instrument in direct sunlight or near a heat source, as this may damage the case or the instrument internals. When installing the instrument, select a location where there is minimal temperature variation, in the vicinity of normal room temperature 23°C (73.4°F).</p>

Vorsichtsmaßnahmen für den Betrieb

Folgende Vorsichtsmaßnahmen müssen getroffen werden, um einen sicheren und korrekten Betrieb des Meßgeräts zu erzielen.

Geräteoberseite	<p>Keine Behälter, die Wasser oder andere Flüssigkeiten beinhalten, auf das Meßgerät stellen. Wenn aus irgendwelchen Grund Wasser in das Meßgerät eindringt, das Gerät sofort vom Netz trennen und einen YOKOGAWA-Verkaufsrepräsentanten oder die YOKOGAWA-Verkaufsabteilung benachrichtigen.</p> <p>Keine großen bzw. schweren Gegenstände auf dem Meßgerät absetzen. Dadurch kann die Geräteoberfläche beschädigt oder die Belüftung behindert werden. Ein Geräteschaden kann die Folge sein.</p>
Transportieren oder Bewegen des Meßgeräts	<p>Vor dem Bewegen des Meßgeräts ist sicherzustellen, daß der Netzstecker abgezogen ist und alle externen Anschlußkabel entfernt sind.</p> <p>Darauf achten daß das Meßgerät während des Transports keinen Stößen ausgesetzt ist. Starke Stöße können zum Schaden am Gerät führen.</p>
Reinigung	<p>Das Gehäuse und die Bedienfelder bestehen meist aus Kunststoffmaterial. Deshalb niemals Lösungsmittel, Lackbenzin, Farbverdünner oder andere chemisch behandelte Reinigungstücher verwenden.</p> <p>Wenn das Bedienfeld oder Gehäuse verschmutzt ist, vorsichtig mit einem sauberen Tuch abwischen.</p> <p>Bei starker Verschmutzung den Schmutz mit einem feuchtem Lappen abwischen, der zuvor in milder Seifenlösung getränkt wurde. Danach mit einem sauberen trockenen Lappen nachwischen.</p>
Lagerung	<p>Wenn das Meßgerät für längere Zeit eingelagert werden soll, zuerst die Batterien für die IC-Speicherkarte herausnehmen (Sonderzubehör). Wenn die Batterien nicht entfernt werden, kann es zum Auslaufen des Elektrolyten kommen.</p> <p>Korrosion kann die Speicherkarte zerstören.</p>
Bei Störungen	<p>Das weitere Betreiben des Meßgeräts ist gefährlich, wenn Rauchbildung, ungewöhnliche Geräusche oder Gerüche bzw. andere Zeichen von Störungen auftreten.</p> <p>In diesem Fall sofort den Netzstecker ziehen. Bei Störungen einen YOKOGAWA-Verkaufsrepräsentanten oder die YOKOGAWA-Verkaufsabteilung benachrichtigen.</p>

Netzka b el	<p>Niemals schwere Gegenstände auf das Netzkabel stellen. Das Netzkabel auch von Wärmequellen fernhalten. Eine Beschädigung des Netzkabels kann einen Stromschlag oder Brand verursachen.</p> <p>Wenn ein Netzkabel beschädigt ist, die Stelle benachrichtigen, bei der das Gerät gekauft wurde. Die Teilenummern der Netzkabel für die unterschiedlichen internationalen Standards werden in Tabelle 1.2 aufgeführt.</p>
Betriebsbereich	<p>Um einen Aufbau von übermäßiger innerer Gerätetemperatur zu vermeiden, darf das meßgerät nicht in einem schlecht belüftbaren Bereich betrieben werden.</p> <p>Das Gerät auch nicht direkter Sonneneinstrahlung oder nahe von Wärmequellen aufstellen, da dadurch das Gehäuse oder innere Bauteile beschädigt werden können.</p> <p>Für das Aufstellen des Meßinstruments einen Platz wählen, der nur minimalen Temperaturschwankungen unterliegt (Raumtemperaturbereich von 23°C).</p>

Mesures de Precaution Pour L'utilisation

Les mesures de précaution suivantes doivent être prises pour assurer une utilisation correcte et en toute sécurité de l'instrument.

Dessus de l'instrument	<p>Ne pas placer de récipients contenant de l'eau, ou autres liquides, sur le dessus de l'instrument. Si, pour une raison quelconque, de l'eau pénètre dans l'instrument, le déconnecter immédiatement de la prise secteur et s'adresser à un représentant ou au service après-vente de YOKOGAWA.</p> <p>Ne pas placer d'objets encombrants ou lourds sur le dessus de l'instrument. Ils pourraient rayer le boîtier, ou obstruer les ouvertures d'aération, et endommager l'instrument.</p>
Transport ou de déplacement de l'instrument	<p>Lorsque l'instrument doit être déplacé, s'assurer qu'il est débranché de la prise murale et que tous les câbles de raccordement externes ont également été débranchés.</p> <p>Veiller à ce que l'instrument ne soit soumis à aucun choc pendant le transport. Soumettre l'instrument à des chocs violents pourrait l'endommager.</p>
Nettoyage	<p>Des matières plastiques ont été utilisées pour la construction du boîtier et du panneau de commande de cet instrument. Ne jamais utiliser de naphta, d'alcool minéral, de diluant ou de chiffon de nettoyage imprégnés de produits chimiques.</p> <p>Si le boîtier ou le panneau sont sales les essuyer sans frotter avec un chiffon doux.</p> <p>Si le boîtier est extrêmement sale, utiliser un chiffon trempé dans un bain très dilué de détergent doux et essoré pour enlever la saleté et essuyer ensuite l'instrument avec un chiffon sec.</p>
Remisage prolongé	<p>Lorsque l'instrument doit être remisé pendant une période prolongée, enlever les piles de la carte de mémoire IC (en option). Si les piles étaient laissées en place pendant le remisage, des fuites d'électrolyte pourraient se produire, ce qui endommagerait la carte de mémoire.</p>
En cas d'anomalies de fonctionnement	<p>Il est dangereux de continuer à utiliser l'instrument lorsqu'il produit de la fumée, un bruit ou des odeurs anormales, ou qu'il donne un signe quelconque de mauvais fonctionnement. Le déconnecter immédiatement de la prise secteur et ne plus l'utiliser. En cas d'anomalies de fonctionnement, s'adresser à un représentant ou au service après-vente de YOKOGAWA.</p>

Cordon d'alimentation	<p>Ne placer aucun objet sur le cordon d'alimentation.</p> <p>Ne jamais mettre le cordon d'alimentation en contact avec un appareil de chauffage. Un cordon endommagé présente des risques d'électrocution et peut être à l'origine d'un début d'incendie.</p> <p>Si le cordon est endommagé, s'adresser au revendeur de l'instrument. Les numéros de pièce des cordons d'alimentation conformes aux diverses normes internationales sont donnés à la table 1.2.</p>
Conditions de fonctionnement	<p>Pour prévenir une augmentation excessive de la température interne, veiller à ne pas placer l'instrument dans un endroit mal aéré.</p> <p>Ne pas placer l'instrument en plein soleil ou à proximité d'une source de chaleur, car ceci pourrait endommager le boîtier ou les circuits internes. Lors de l'installation de l'instrument, sélectionner un emplacement où les variations de température sont minimales et où la température ambiante est proche de 23°C.</p>

1.3.5 Operational Check

Model 2532 has a self-test function which automatically performs certain operational tests whenever power is turned ON. You should use this function to check whether there has been any damage to the major components due to accidents during shipment.

(1) Connection to AC Power Supply

- ① To prevent an electric shock or a fire, be sure to use power supply cord and 3 to 2 pin adapter supplied by YOKOGAWA. Main power plug must be plugged in an outlet with protective grounding terminal only. Do not invalidate protection by using an extension cord without protective grounding.
- ② Check that the instrument power switch (on the front panel) is OFF, and then connect the power cord plug to the nearest receptacle, as shown in Figure 1.4.

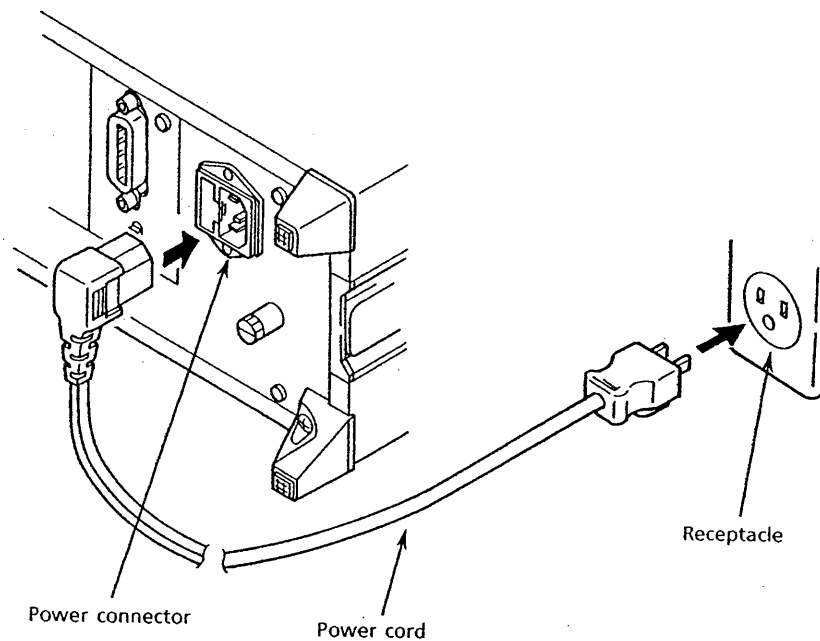

Figure 1.4 Connection to AC Power Supply

(2) Turn Power Switch ON

- By turning the power switch ON, the internal test program starts.
- The tests include a RAM test, DMAC test, DSP test, EEPROM test, and a voltage test of the panel setup information backup battery.

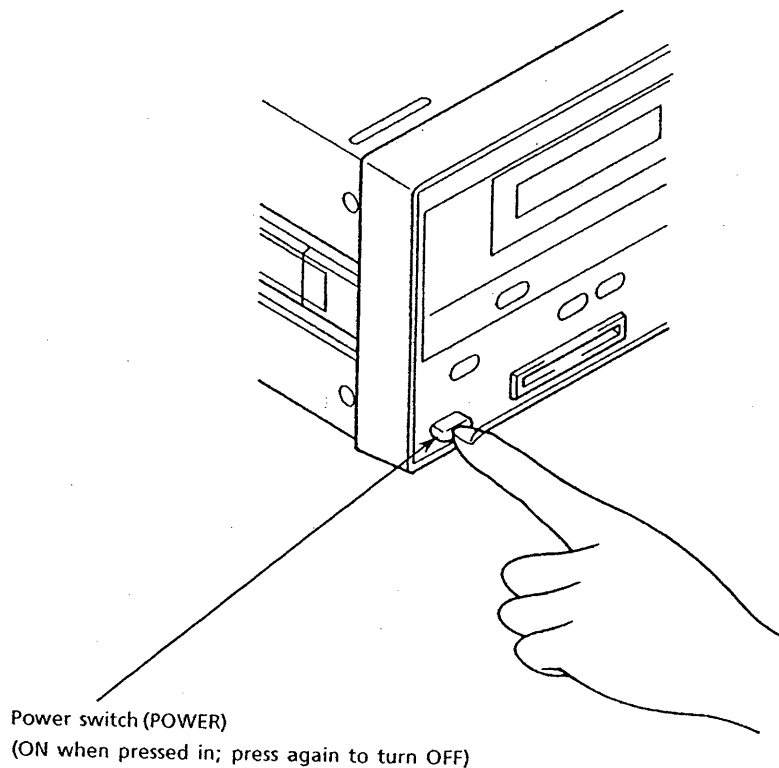

Figure 1.5 Turning Power Switch ON

(3) Judging Results of Self-Test**① If Test Results are Normal**

After performing the tests indicated above the instrument displays, if results are normal, the mode, system configuration, and version number each for a few seconds in the format shown in Figure 1.6 (for Model 253221) or in Figure 1.7 (for Model 253222), and then goes to measurement mode. From this system configuration display the user can ascertain which options are installed in the instrument by checking the displayed information against the tables of hardware configuration versus model and suffix code numbers.

Verify that the instrument that you have received corresponds to the specifications that were ordered.

• Opening messages for the 253221 (with GPIB)

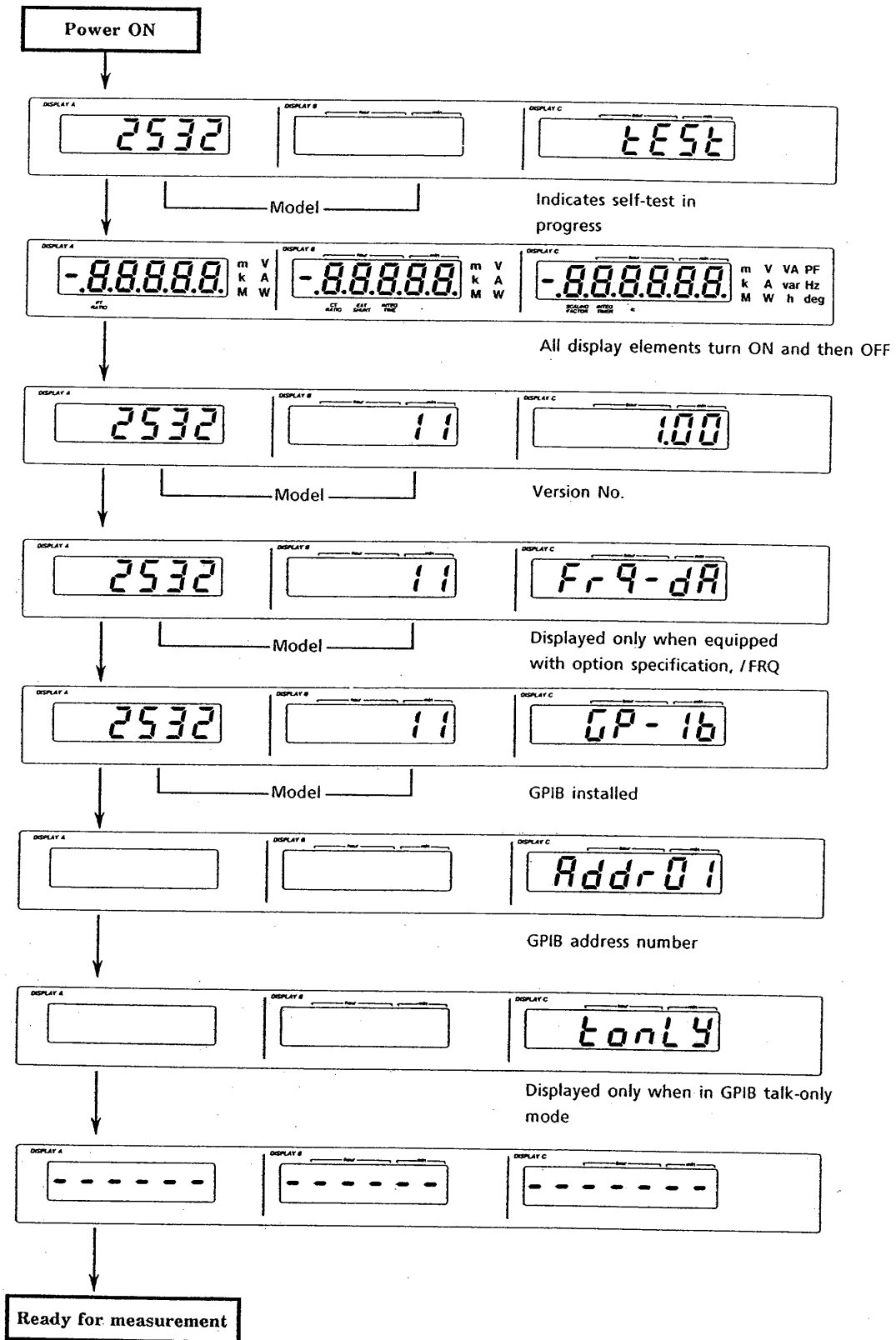

Figure 1.6 Opening Messages for 253221 (with GPIB)

Opening messages for the 253222 (with RS-232-C)

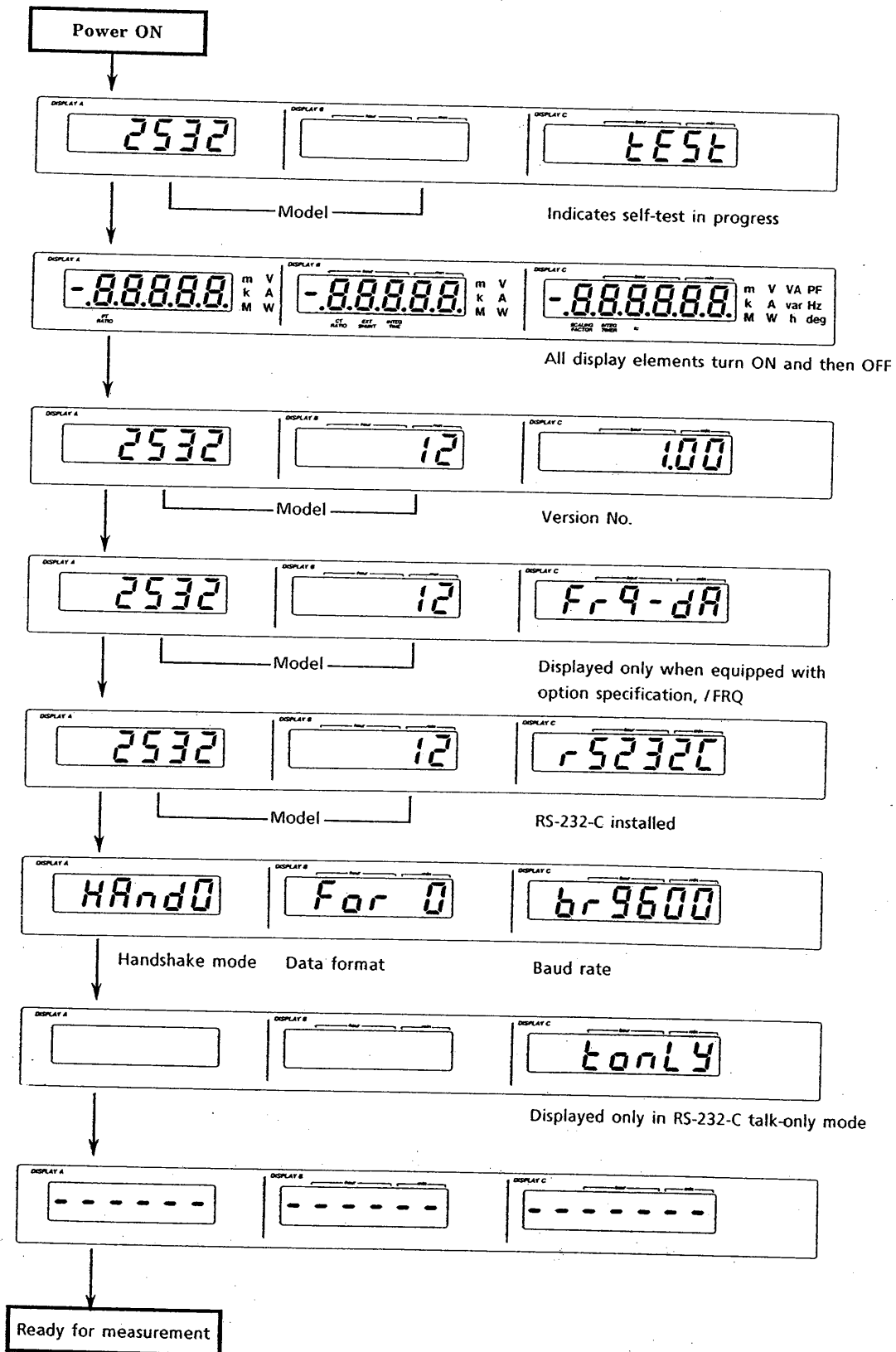

Figure 1.7 Opening Messages for 253222 (With RS-232-C)

② If Test Results are Abnormal

If any of the tests described in (2) above yields an abnormal result, the test stops, and one of the error messages shown below appears in DISPLAY C.

Err 80 : For RAM failure

Err 81 }
Err 84 } : For DMAC failure

Err 87 : For DSP failure

Err 61 }
Err 64 } : For EEPROM failure
Err 65 }
Err 66 }

NOTE

If any of the error messages indicated above is displayed, the instrument will not operate normally. Turn power OFF, and contact YOKOGAWA's sales representative or YOKOGAWA sales division (see list on the back of this manual) with the model, serial number, and the error message that was displayed.

- ③ In the opening message sequence, if error message 60 (*Err 60*) appears in DISPLAY C after the entire display has lit up, this indicates that the voltage of the panel setup information backup battery is low. This indicates that the panel setup information has not been preserved. Even if error message 60 has been displayed, the opening messages continue, and the instrument continues on to measurement mode. When power is ON, the battery is charging.

Err 60 : Displayed when the panel setup information backup battery voltage is low

1.4 Block Diagram and Operations

(1) Block Diagram

Figure 1.8 shows a block diagram of Model 2532.

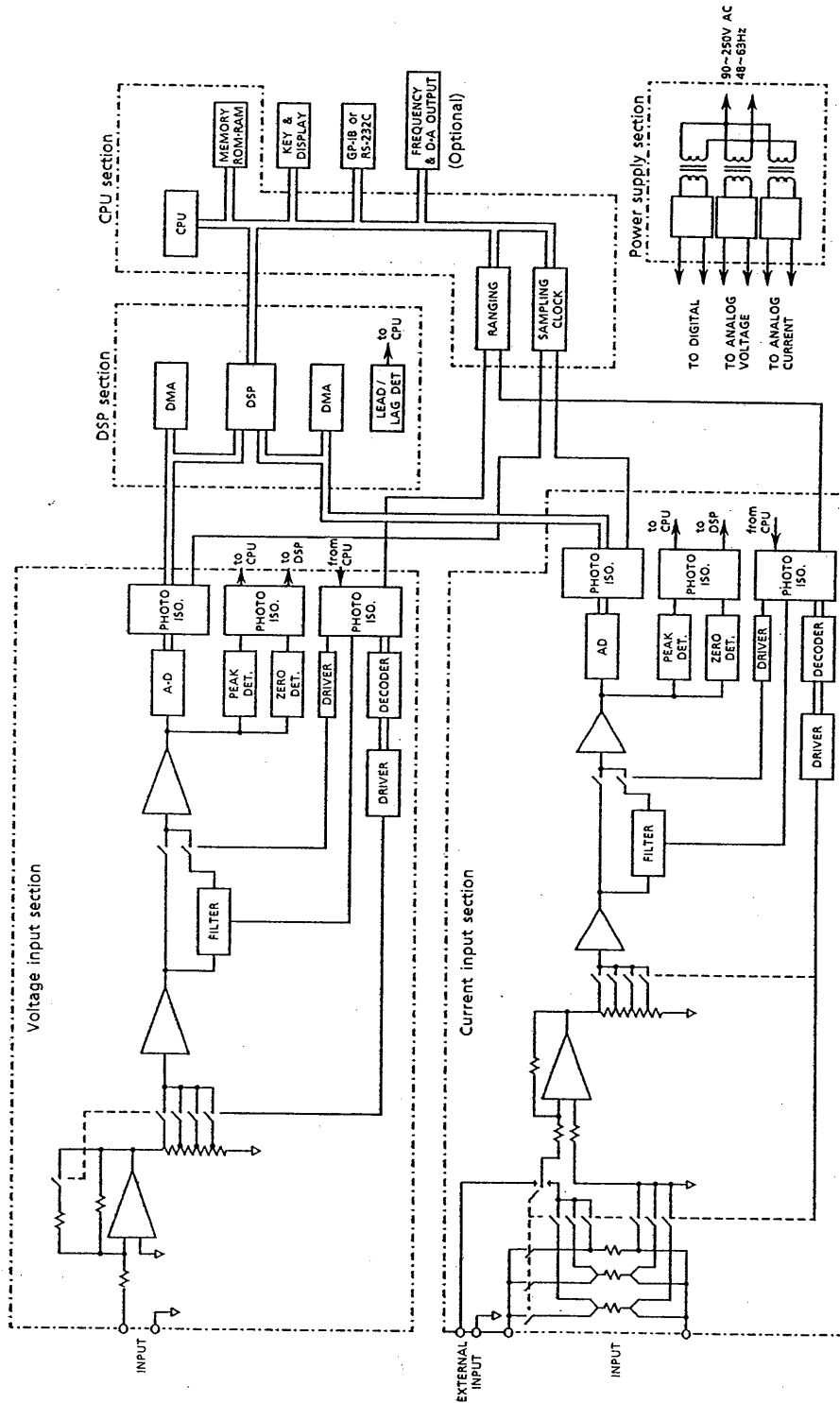

Figure 1.8 Model 2532 Block Diagram

(2) Operating Principles

Figure 1.8 is a block diagram of the digital power meter.

The digital power meter comprises a voltage input section, current input section, DSP section, CPU section, and power supply section, etc.

In the voltage input circuit, an input voltage is converted to an appropriate voltage by means of voltage dividers and an operational amplifier, and then input to an A-D converter.

In the current input circuit, an input current is converted to an appropriate voltage by means of shunts and an operational amplifier, and then input to an A-D converter.

The outputs from the A-D converters are isolated by photoisolators and transmitted to the DSP section.

In the DSP section, if the FREQ RANGE setting is HI or MID, the isolated A-D converter output signals from the voltage and current input circuits are stored temporarily via internal memory; after a fixed amount of data has been accumulated, it is then extracted from the internal memory area and rms value, average value, and active power computations are performed on the data. If the FREQ RANGE is LO, the A-D converter output data is transmitted directly to DSP, where the same computations are performed.

Results of the computations performed in the DSP section are transmitted to the CPU, which computes the reactive power, apparent power, and power factor, performs PT and CT ratio scaling, and displays the results.

Outputs can be generated via GPIB or RS-232-C, or D-A output (optional).

1.5 Specifications

Input Section

Item	Input	Voltage	Current
Input circuit system	Floating inputs		
		Resistive voltage divider	Shunt input
Rated values (Range)		10/15/30/60/100/150/300/600V	20/50/100/200/500mA 1/2/5A (current input) 50/100/200mV (external shunt input ranges)
Input Impedance		Approx. 1.3M Ω (all ranges) (approx. 15pF in parallel)	20/50/100mA : Approx. 2 Ω 200/500mA/1A : Approx. 0.2 Ω 2/5A : Approx. 0.05 Ω (approx. 0.4 μ H in series) External shunt input resistance : Approx. 1k Ω
		Approx. 100pF between input terminals (\pm) and case	
Frequency range		DC, and 20Hz to 400kHz	
Instantaneous maximum allowable input (for 1sec)		Peak value of 1400V or 3.5times the range, whichever lower	Peak value of 7times the range, or rms value of 3times range, whichever lower (maximum, 10Arms) External shunt input range : Peak voltage is 5V max.
Continuous maximum allowable input (at 50/60Hz)		Peak of 1000V, or rms value of 2times range, whichever lower	Peak of 5times range, or rms value of 2times range whichever lower External shunt input range : Peak voltage is 1V min.
Continuous maximum common voltage 50/60Hz		600Vrms	600Vrms
Common voltage influence (at 50/60Hz)		\pm 0.025% of range max. (with input terminals shorted, 600V applied between input and case)	\pm 0.025% of range max. (with input terminals open, 600V applied between input terminals (\pm) and case)
Input terminal		Binding posts	Large binding posts External shunt input : 4-pin round connector
Filter		Can select OFF, or cutoff frequency (fc) of 250/500/1000/2000Hz, or any desired setting (250Hz to 2000Hz)	
Accuracy (with filter ON)		V, A: Add 2% of range to measurement accuracy at fc/10 W (at cos ϕ =1): Add 4% of range to measurement accuracy at fc/10	
Overrange detection		Approx. 3.5 times the range (alarm lamp lights when detected)	
A-D conversion section		Simultaneous sampling of voltage, current input Resolution: 12bits Maximum conversion rate: 1MS/s	
Range selection		V, and A can be independently selected using manual, automatic, or external control (GPIB or RS-232-C)	
Auto range selection		Range upshift: If peak value exceeds 350% of the rated range, or if the measured value exceeds 110% of rating Range downshift: If the measured value falls below 30% of the rated range	

■ Measurement Functions

Item	Input	Voltage, current	Power	Remarks
System		Digital multiplication System		
Crest factor		At rated input: 3		
Frequency range (for display update interval of 1.6sec)	HI MID LO	DC, 2kHz to 400kHz DC, 200Hz to 80kHz DC, 20Hz to 10kHz		
Waveform measurement time (see note)		For display update interval (SAMPLE RATE) of 0.4sec HI : Approx. 12ms MID : Approx. 50ms LO : Approx. 0.4s For display update interval (SAMPLE RATE) of 1.6sec. HI : Approx. 48ms MID : Approx. 200ms LO : Approx. 1.6s		
Accuracy (display)	DC	$\pm(0.2\% \text{ of rdg} + 0.2\% \text{ of range})$	$\pm(0.3\% \text{ of rdg} + 0.2\% \text{ of range})$	Under reference conditions, as follows: Temperature: $23 \pm 3^\circ\text{C}$ Humidity: 45% to 75% R.H. Power supply voltage: $100\text{V} \pm 1\%$ Input waveform: Sine wave Common mode voltage: 0V Calibration interval: 90days Scaling: OFF Input range: 10% to 110% of range Display update interval: 1.6sec Filter: OFF When output is $\cos\phi = 1$ Using Yokogawa standard instrument Accuracy guaranteed within indicated frequency range
	20Hz to 30Hz	$\pm(1.0\% \text{ of rdg} + 0.4\% \text{ of range})$	$\pm(2.0\% \text{ of rdg} + 0.6\% \text{ of range})$	
	30Hz to 45Hz	$\pm(0.3\% \text{ of rdg} + 0.2\% \text{ of range})$	$\pm(0.5\% \text{ of rdg} + 0.2\% \text{ of range})$	
	45Hz to 66Hz	$\pm(0.2\% \text{ of rdg} + 0.2\% \text{ of range})$	$\pm(0.3\% \text{ of rdg} + 0.2\% \text{ of range})$	
	66Hz to 20kHz	$\pm(0.3\% \text{ of rdg} + 0.2\% \text{ of range})$	$\pm(0.5\% \text{ of rdg} + 0.2\% \text{ of range})$	
	20kHz to 100kHz	$\pm(0.6\% \text{ of rdg} + 0.2\% \text{ of range})$	$\pm(1.0\% \text{ of rdg} + 0.4\% \text{ of range})$	
	100kHz to 200kHz	$\pm(1.0\% \text{ of rdg} + 0.4\% \text{ of range})$	$\pm(2.0\% \text{ of rdg} + 0.6\% \text{ of range})$	
	200kHz to 300kHz	$\pm 2\% \text{ of range}$	$\pm 3.5\% \text{ of range}$	
	300kHz to 400kHz	$\pm 3\% \text{ of range}$	$\pm 5.0\% \text{ of range}$	
Power factor influence	20Hz to 20kHz	—	$\pm 0.4\% \text{ of range}$	When $\cos\phi = 0$
Temperature coefficient		$\pm 0.05\% \text{ of range} / ^\circ\text{C}$		5~20, 26~40°C

Note: In Model 2532, there will be cases in which only segments of the total voltage and current waveforms within the display update interval are used. The interval whose segment is used in measurement depends on the display update interval and on the frequency range. This interval is defined as the waveform measurement time.

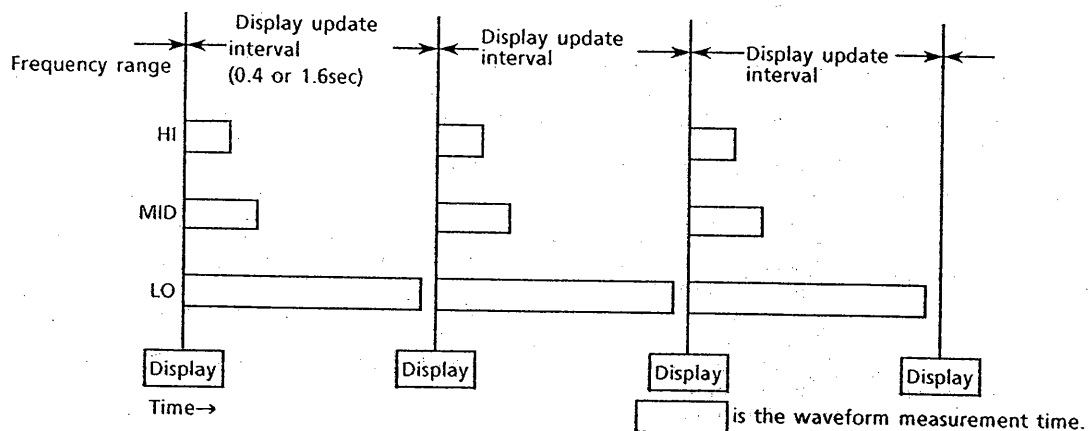

■ Display Functions

Display : LED (light-emitting diode)

Displayed information (3displays)

Display	Displayed information	Maximum display value
A	V, A, W	V, A : 14000 (W determined by maximum V, A, display)
B	V, A, W Elapsed integration time	Wh, Ah : 999999
C	V, A, W, VA, var, PF, deg, Wh, Ah (Hz: With option)	Hz : 19999

Units display : m, k, M, V, A, W, VA, var, Hz, h, deg

Display update : 0.4seconds or 1.6seconds (selectable)

Interval (SAMPLE RATE)

Response time : For 0.4sec display update interval, approx. 0.8sec

For 1.6sec display update interval, approx. 3.2sec

(Time to settle to final value, within specified accuracy, after step change from 10% to 100% of range, or 100% to 10% of range)

● Display Scaling Function

Significant digits : Automatically selected according to significant digits in voltage/current range

Setting range : 0.0001 to 10000

Setting value : "DISPLAY A": PT ratio
"DISPLAY B": CT ratio
"DISPLAY C": Power scaling factor

● Display Averaging Function

Method : Exponential averaging

Attenuation factor : 8 (fixed)

■ Computation Functions

	Apparent power (VA)	Reactive power (var)	Power factor (PF)	Phase angle (deg)
Computation formula	$V \times A$	$\sqrt{(V \times A)^2 - W^2}$	$\frac{W}{V \times A}$	$\cos^{-1} \left(\frac{W}{V \times A} \right)$
Computation range	Rated value determined by V, A range	Rated value determined by V, A range (≥ 0)	-1~0~1	0~180
Computation accuracy	$\pm 0.05\%$ of rated value (VA)	$\pm 0.05\%$ of rated value (var)	± 0.001	± 0.1 deg relative to value computed from PF

Note1: The reactive power, (var), apparent power, (VA), power factor, (PF), and phase angle, (deg) for this instrument are obtained from the voltage, current, active power, etc. by digital computation. In the case of non-sinusoidal (distorted) input waveforms, these values may differ from those obtained with instruments employing different measurement principles.

Note2: For display of phase lead/lag, V and A inputs must be at least 30% of rated value (no display if less than 30%). Phase lead/lag detection accuracy is ± 5 deg.

■ Integrator Functions (Wh, Ah)

- Maximum display : ± 999999 (six digits)
- Maximum integration time : 999h
- Measured frequency range : DC, 20Hz to 16kHz
- Display : Displays Wh or Ah in "DISPLAY C"
- Display update interval : 1 second
- Timer : Integration can be stopped automatically based on timer setting.
Setting value: 000h:00min to 100h:00min
("000h:00min" selects manual mode)
- Elapsed time : Displays time elapsed since integration start in "DISPLAY B".
- Count overflow : If integration value overflows, elapsed time is saved and integration is stopped.
- Accuracy : \pm (measurement accuracy $\pm 0.2\%$ of reading)
- Timer accuracy : $\pm 0.02\%$
- Remote control : Start, stop, and remote control can be performed using an external contact signal.
- Optional functions : Display resolution can be set using internal DIP switch.
- DISPLAY A : Nothing displayed

■ Communication Specifications

GPIB

Electrical and mechanical specifications

Conform to IEEE Std 488-1978

Functional specifications

SH1, AH1, T6, L4, SR1, RL1, PP0, DC1, DT1, C0

RS-232-C

Transmission mode : Asynchronous start-stop

Baud rate : 75, 150, 300, 600, 1200, 2400, 4800, 9600bps

■ IC Memory Card

IC memory cards of up to 64Kbytes capacity can be used.

Functions : Storage and retrieval of measured data
Saving and reloading of panel setup information

■ Frequency Measurement (With Option)

Measurement method : Reciprocal method

Measured input : Voltage or current

Display update interval	Measured frequency range
0.4sec	20Hz to 1000kHz
1.6sec	2Hz to 100kHz

Accuracy : $\pm(0.1\% \text{ of range} + 1 \text{ digit})$

Minimum input sensitivity : $\pm 10\% \text{ of range}$

Display range : 2.000Hz to 1000.0kHz ($4\frac{1}{2}$ digits)

Display update interval : 0.4sec or 1.6sec

■ D-A Converter Output (With Option)

System : 16bit PWM (pulse-width modulation)

Output voltage : $\pm 5V$ for each rated value (maximum, approx. 7.5V)

Accuracy : \pm (measurement accuracy + 0.2% of full scale)

Temperature coefficient : $\pm 0.05\% \text{ of FS}/^\circ\text{C}$

Output data : Any one of the data types that can be displayed in "DISPLAY C" (V, A, W, VA, var, PF, deg, Wh, Ah, Hz)

Output update interval : Same as display update interval

Response time : Display response + approx. 400ms
(Time to settle to final value, within specified accuracy, after step change from 10% to 100% of range, or 100% to 10% of range)

■ General Specifications

External control input and outputs :

Signal name	Input/Output	Action	Level
EXT HOLD	Input	Display hold	TTL
EXT TRIG	Input	Display update	TTL
EXT START	Input	Integration start	TTL
EXT STOP	Input	Integration stop	TTL
EXT RESET	Input	Integration reset	TTL
INTEG BUSY 100Hz	Output Output	Integration in progress Clock (timer timebase)	TTL TTL

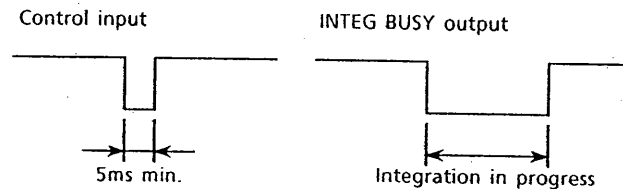

- Operating temperature and humidity range : 5 to 40°C, 20~80% R. H.
- Warm-up time : Approx. 1 hour (to satisfy all specifications)
- Insulation resistance : 50MΩ min. at 500V DC (between input terminals and case, between input terminals and output terminals, between voltage terminals and current terminals, between input terminals/output terminals/case and power supply)
- Withstanding voltage : 2200V AC, 50/60Hz, for 1minute between input terminals and case, between input terminals and output terminals, between input terminals and power supply, and between voltage terminals and current terminals. 1500V AC, 50/60Hz, for 1minute between output terminals, case, and power supply.
- Power source : 90 to 250V AC, 48 to 63Hz
- Power consumption : Approx. 30 to 75VA
- External dimensions : Approx. 132×426×350mm (excluding legs, terminals, etc.)
- Weight : Approx. 8kg
- Accessories : One power cord, one fuse (1A time-lag; one already installed in unit; same type is used for both 100V and 200V systems), one input cable for use with external shunts, one remote control connector, one instruction manual

1.6 Outline Drawings

Models 253221 / 253222

Unit : mm (approx. inch)

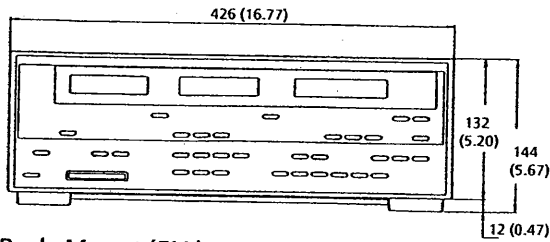
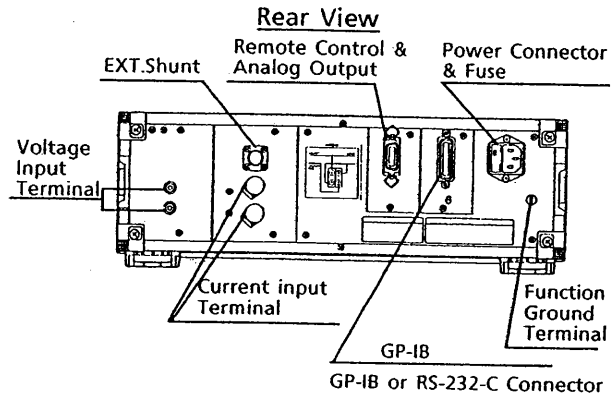
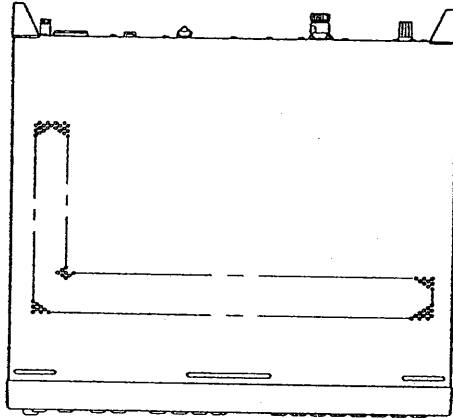

Rack Mount (EIA)

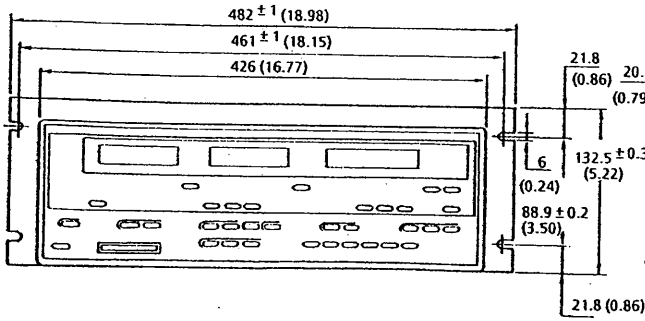
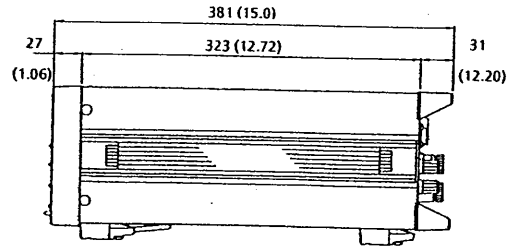

Rack Mount (JIS)

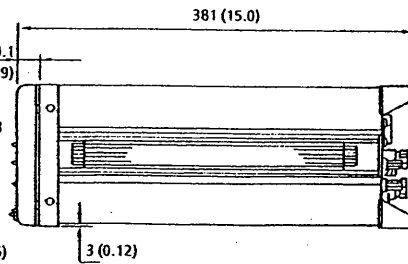
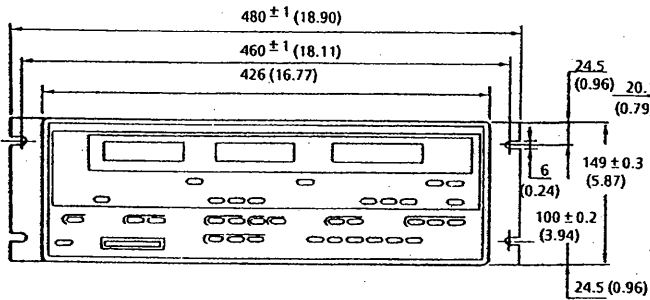
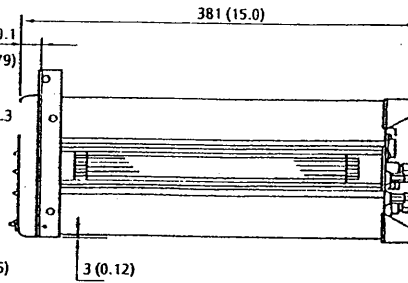

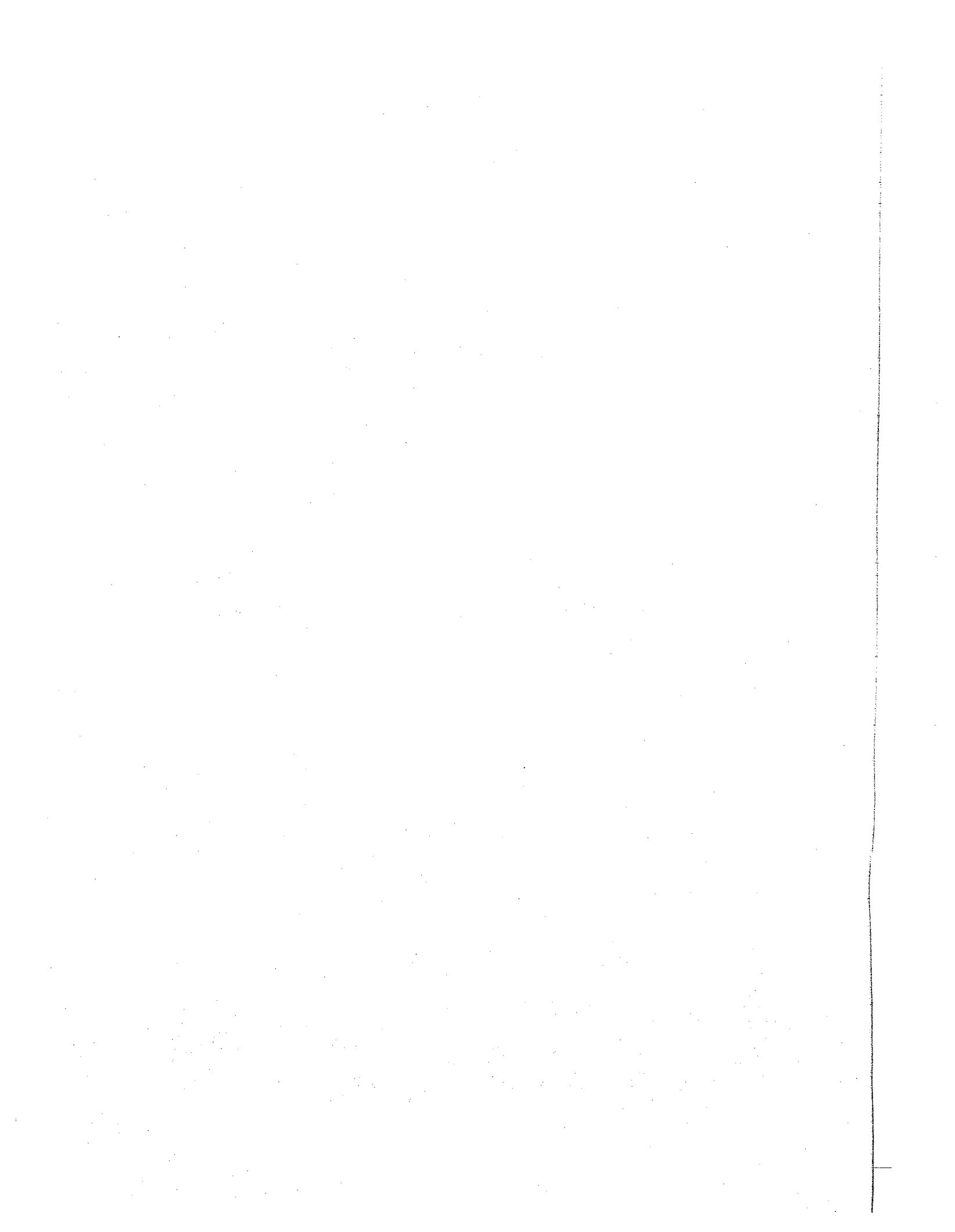

2. COMPONENT NAMES AND FUNCTIONS

2.1 Front Panel

253221 / 253222

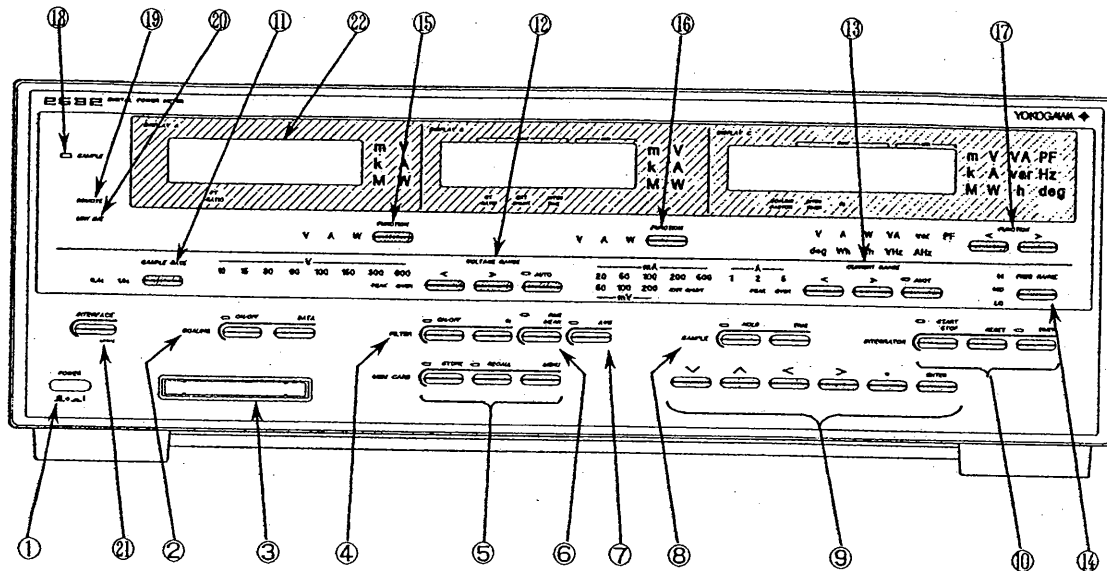

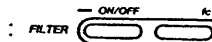

Figure 2.1 Front Panel Component Names

- ① **POWER switch** :  : Turns power ON/OFF. Pressing the switch turns power ON, pressing it again turns power OFF. When power is turned ON, the self-test is executed automatically, and the opening messages appear on the display as described in Section 1.3.5.
- ② **Scaling keys** :  : Two keys one to turn scaling function ON/OFF, and DATA key used to set scaling factors. Pressing the ON/OFF key turns scaling ON, and causes the LED above the key to turn ON. Pressing this key again turns scaling OFF. At initialization (initial setup), SCALING is OFF. See Section 3.5.4 for the procedure for setting the scaling factors.
- ③ **IC memory card slot** : Slot for inserting the IC memory card. For details, see Section 4.3. If no IC memory card is used, insert the dummy card, B9586NG, to protect the slot.

Chapter
2

④ Filter keys



Two keys one turns filter function ON/OFF, the other fc key is used to select/set the cutoff frequency of the filter circuit.

Pressing the ON/OFF key turns filtering ON, and causes the LED above the key to turn ON. Pressing this key again turns filtering OFF.

At initialization (initial setup), FILTER is OFF.

See Section 3.5.5 for the procedure for setting/selecting the cutoff frequency.

⑤ IC memory card keys



STORE key for storing measured data to the IC memory card, RECALL key for retrieving data to the 2532 after storage to the IC memory card, and MENU key to load/save IC card mode settings, and initialize and panel setup information.

The LED above the key is ON when store or recall is in progress. Pressing one of these keys a second time cancels the STORE or RECALL mode.

For detailed setting procedures, see Section 3.5.7.

⑥ Voltage mode select key



Selects whether the voltage measurement will be displayed as the true rms value (RMS) or rms-calibrated average rectified value (MEAN).

Pressing the key once changes the instrument to MEAN mode and turns off the LED above the key. Pressing the key a second time turns on the LED, and changes the instrument to RMS mode. At initialization, the instrument is in RMS mode.

When measuring a distorted signal, use "RMS" mode to measure and display.

Using "MEAN" mode performs measurement using average rectified values, and displays an "rms" value assuming that signal is a sine waveform, so that the displayed "rms value" is equal to the "MEAN \times 1.1107".

⑦ Averaging key



AVG key turns ON/OFF the function that averages measured data.

Pressing the key turns AVG to ON, and turns on the LED above the key. Pressing the key a second time, turns the LED off, and turns AVG to OFF.

At initialization, AVG is OFF.

⑧ Sample mode keys



These keys switch the sampling (display interval) between free-run (Free Run: 0.4s or 1.6s), and hold.

Pressing the HOLD key turns on the LED above the HOLD key, and stops measurement operations. However, if an integration operation is in progress, measurement continues, and the hold affects display only.

The display area (DISPLAY A, DISPLAY B, DISPLAY C) holds the values measured immediately before the key was pressed.

If no data exists, "(-) - - - - -" is displayed.



In hold status, pressing the TRIG key updates the measured value once each time the key is pressed.



Pressing the HOLD key a second time when the HOLD LED is lit turns off the LED, and changes the instrument to free run mode.

At initialization, the instrument is set to free run mode (display update interval, 1.6s).

⑨ Setup keys : 

Keys used to select and enter setup parameters.

  ; Keys used to increase (∧) or decrease (∨) a selected digit in a numeric value, or to select menu items.

  ; Keys used to move left and right along digits in numeric value setup parameters.

Continuing to press one of these keys after having reached the highest or lowest digit has no effect.

 ; Key used to move the decimal point.

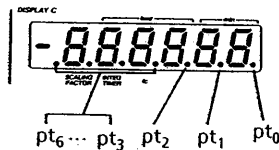

Repeated depressions of the key move the decimal point cyclically through its usable range as follows
pt₆→pt₅→...→pt₀→pt₆

 ; Key used to place parameter setup values and setup item selections into effect.

⑩ Integrator keys : 

Keys used when performing current integration or power integration.

START/STOP key ; Pressing this key turns on the LED above the key, and starts integration operations.

Pressing this key a second time turns off the LED, and stops integration operations.

RESET key ; Key for clearing integration data. The integration operation must be stopped to enable this key.

TIMER key ; Key used to set the integration time.

The START/STOP and RESET keys are disabled except when “Wh” or “Ah” is selected with FUNCTION for DISPLAY C.

See Section 4.5 for details concerning the integrator function.

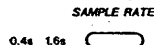
⑪ Sample rate key : 

Key used to set the rate at which input is captured. Each time the key is pressed, the rate switches between 0.4sec ↔ 1.6sec.

At initialization, rate is set to 1.6s. Normally, 1.6s is used.

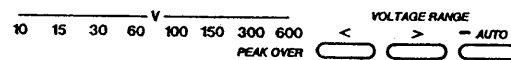
⑫ Voltage range select keys : 

Used to select the voltage range.

 ; Pressing this key turns on the LED above the key, and switches the instrument to AUTO.

Pressing the key a second time turns off the LED, and changes the instrument to manual range. The measured range is fixed at the range being measured immediately before the key was pressed.

In auto range, pressing the “<” and “>” keys changes the instrument to manual range, and sets the range at one range down (using “<”) or at one range up (using “>”) from the range in auto range.



- ; Range down key. Each time the key is pressed the range moves to the left.
- ; Range up key. Each time the key is pressed the range moves to the right.

There is no movement if the ">" key is pressed on the 600V range, or if the "<" key is pressed on the 10V range.

During integration operations, the range is fixed and cannot be changed.

Performing a STOP → RESET operation for integration enables the range to be changed.

- PEAK OVER ; This indicator lights when using a fixed range if the peak value in the voltage waveform exceeds approximately 350% of the range. If auto range is in use, exceeding that level causes the range to be increased.

At initialization, the instrument is set to manual range of 600V.

- ⑬ Current range select keys :

mA					A			CURRENT RANGE		
20	50	100	200	500	1	2	5	<	>	AUTO
mV					PEAK OVER					

Used to select the current range.

Functions for each key are the same as in the case of voltage range, except as follows.



- ; No range shift from 5A to 50, 100, 200mV. In 50, 100, and 200mV (EXT SHUNT) ranges, AUTO key is disabled.



- ; Each time the key is pressed, the range shifts as follows.
5A → 50mV → 100mV → 200mV.



- ; Each time the key is pressed, the range shifts as follows.
200mV → 100mV → 50mV → 5A Range cannot be increased from the 200mV range, or decreased from the 20 mA range.
- During integration operations, the range is fixed and cannot be changed.

Performing a STOP → RESET operation for integration enables the range to be changed.

- PEAK OVER ; This indicator lights when using a fixed range if the peak value in the current waveform exceeds approximately 350% of the range. If auto range is in use, exceeding that level causes the range to be increased.

- ⑭ Frequency range key ;

HI FREQ RANGE		
MID	LO	<input type="checkbox"/>

Selects HI (DC, 2kHz to 400kHz), MID (DC, 200Hz to 80kHz), or LO (DC, 20Hz to 10kHz) for measurement. The numeric values in () indicate values for display update interval of 1.6s except when the integrator function is in use.

Each time the key is pressed, the setting cycles as follows. HI → MID → LO → HI.

At initialization the instrument is set to LO.

Only the LO range (DC, 20Hz to 16kHz) is enabled for integrator functions. When integration (Wh or Ah) starts, if the instrument is in HI or MID range, it automatically goes to LO range.

⑮ ⑯ **Function keys** : V A W 

Used to select the display functions for DISPLAY A and DISPLAY B.







"V" selects voltage display, "A" selects current display, and "W" selects power display.

Each time the key is pressed the setting cycles as follows, and the LED for the selected function turns on. V → A → W → V.

At initialization, the instrument is set to the following functions.

DISPLAY A ; V (voltage display)

DISPLAY B ; A (current display)

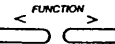
⑰ **Function keys** :       

Used to select the display function (measured item) for DISPLAY C.

 ; Each time the key is pressed, the function changes to the left. The selection cycles as follows.

$V \leftarrow A \leftarrow W \leftarrow VA \leftarrow var \leftarrow PF \leftarrow deg \leftarrow Wh \leftarrow Ah \leftarrow VHz \leftarrow AHZ \leftarrow$

 ; Each time the key is pressed, the function changes to the right. The selection cycles as follows.

$\rightarrow V \rightarrow A \rightarrow W \rightarrow VA \rightarrow var \rightarrow PF \rightarrow deg \rightarrow Wh \rightarrow Ah \rightarrow VHz \rightarrow AHZ \rightarrow$

At initialization, the function is set to W. However, in integration operations (Wh or Ah), the only selections that can be made are Wh ↔ Ah.

See Section 3.5.2 for information in each display when Wh, Ah, VHz, and AHZ is selected.

⑱ **Sample display LED** : 

This LED flashes for the time (0.4sec or 1.6sec) specified by the display update interval (SAMPLE RATE) key, when the LED flashes, the display data is updated.

Note that if the HOLD mode is selected with the sample mode key in ⑧, this LED is off, pressing the TRIG key causes the LED to flash once after the sample rate time.

During integration operations, the LED flashes every second.

⑲ **Remote display LED** : 

This LED lights when the instrument is in remote mode, using a GPIB interface (253221) or RS-232-C interface (253222).

⑳ **Battery display LED** : 

When an IC memory card has been inserted, this LED lights if the voltage of the IC memory card battery is below the rated voltage.

If the LED is on, replace the battery as described in Section 4.3, "Memory Card".

㉑ **Interface/local key** : 

The functioning of the 2532 changes as shown in Table 2.1 according to whether it is in LOCAL or REMOTE mode.

Table 2.1

2532 mode	Interface setup		Mode
	GBIB (253221)	RS-232-C (253222)	
Local	Address setup	Mode setup, data format setup, transmission rate setup	
Remote			Switch REMOTE ↓ LOCAL

Display

There are three displays, DISPLAY A, DISPLAY B, and DISPLAY C, all of which can display data at the same time. Table 2.2 shows the display contents for each of these displays in the individual modes.

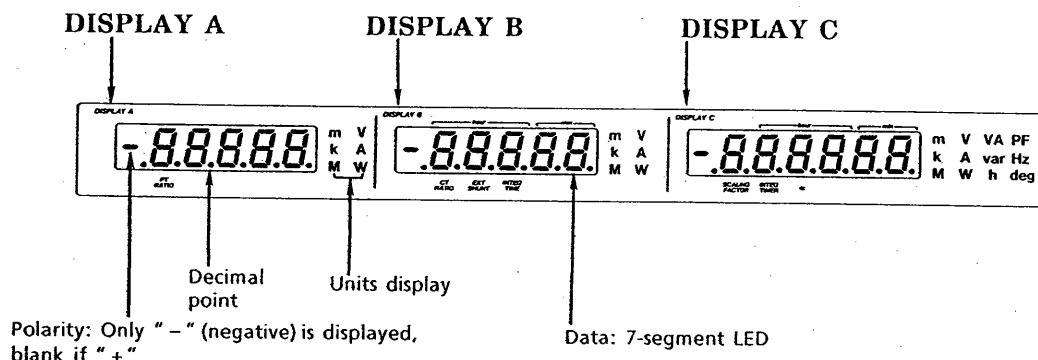

Table 2.2 Displayed Information for Each Mode

DISPLAY	Mode	Displayed information
A	Measured data Scaling data RS-232-C	V or A or W PT ratio Handshake mode
B	Measured data Scaling data Integration Store mode Recall mode NS setting Recall readout starting point setup RS-232-C	V or A or W CT ratio or external shunt current value Elapsed integration time Store rate Recall rate NS value Recall readout starting point (RD) Data format
C	Measured data Scaling Integration Filter Memory card GPIB RS-232-C	One data from among V, A, W, VA, var, PF, deg, Wh, Ah, VHz, AHZ Scaling factor Timer time setup Cutoff frequency Various setup/mode selections Address Baud rate

For details concerning the display range of computed data, etc., see Section 3.5.2.

2.2 Rear Panel

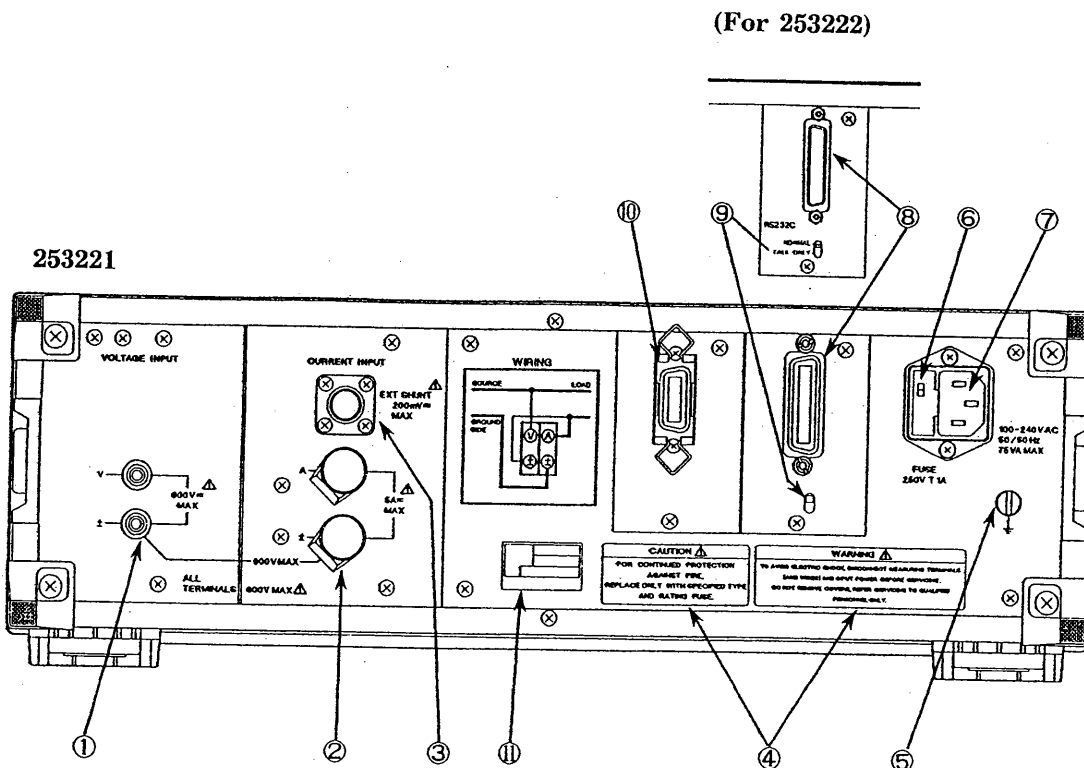

Figure 2.2 Rear Panel Component Names

- ① Voltage input terminal
- ② Current input terminal
- ③ External shunt input connector

The input terminals include the voltage and current input terminals, and also an input connector for external shunts for current measurement.

Once the inputs have been connected to the terminals and/or connectors, voltage and current range changes can be made via the front panel keys with all circuits energized.

Note, however, that connections must not be made to both the current terminals and external shunt input connector at the same time.

- ④ Warning label plates
- ⑤ Function ground terminal

This ground terminal cannot be used as protective ground terminal.

Use this terminal for the functional purpose.

- ⑥ Power supply fuse

Use a 1A time-lag fuse with a 250V voltage rating (Depends on the suffix code referred to on page 1-4, for both 100V and 200V systems).

⑦ **Power connector**

This is a 3-pin connector, one of the pins being a ground connection. The power cord provided in the accessories is to be connected to this connector.

⑧ **GPIB connector (for 253221)**

RS-232-C connector (for 253222)

⑨ **Mode selection switch**

For Model 253221, selects mode (ADDRESSABLE or TALK ONLY) for GPIB interface.

For Model 253222, selects mode (NORMAL or TALK ONLY) for RS-232-C interface.

⑩ **Remote control/analog (D-A) output connector**

Connector used for measurement start, integration start/stop, and remote control via external contact signals. Can also be used to obtain an analog output of the integration values or other measurements such as VA, PF, var, or Hz (with option), when the D-A output option is installed.

⑪ **Instrument serial number plate**

Used to inscribe the model and suffix codes, and instrument serial number.

3. OPERATING PROCEDURES

3.1 General Operating Procedures

Figure 3.1 shows the general operating procedures for this instrument in flowchart form. This section describes these procedures in the same order.

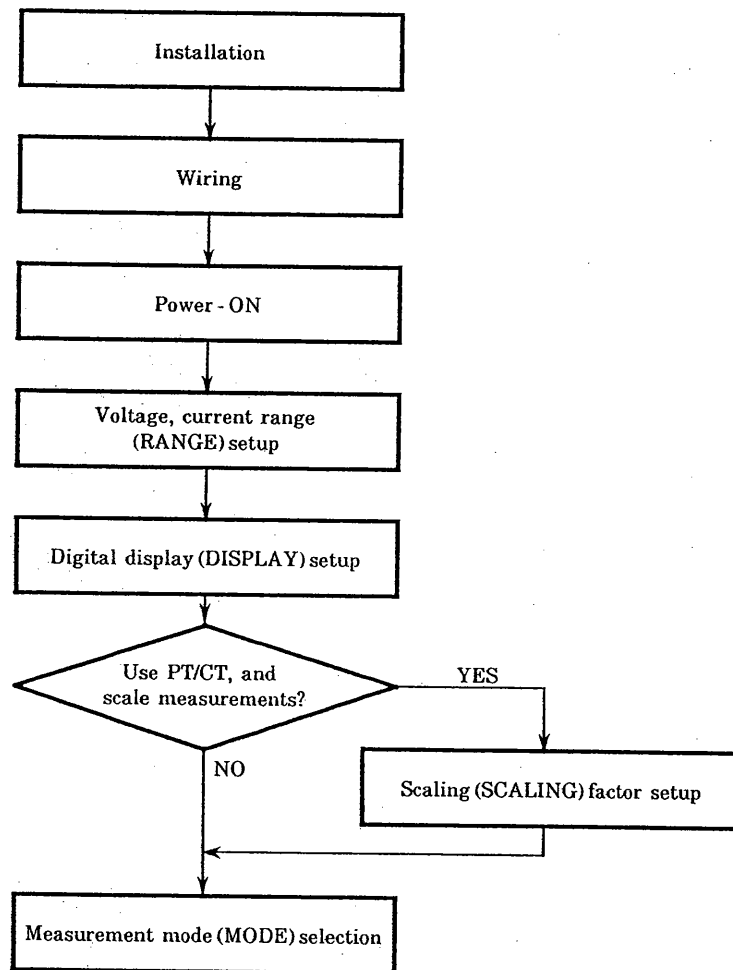

Figure 3.1 General Operating Procedures

3.2 Installation

This instrument can be used as a desktop instrument on top of a table or bench, or can be used as a rack mount type instrument by installing the appropriate mounting hardware, sold separately.

(1) Desktop Instrument

This instrument can be placed on a table top either level or at an angle.

To use the instrument at an angle, pull out the stand on the bottom of the instrument, as shown in Figure 3.2. When the stand is nearly perpendicular to the bottom of the instrument, it locks into place, holding the instrument at an angle. To unlock the stand, press in the sides of the stand.

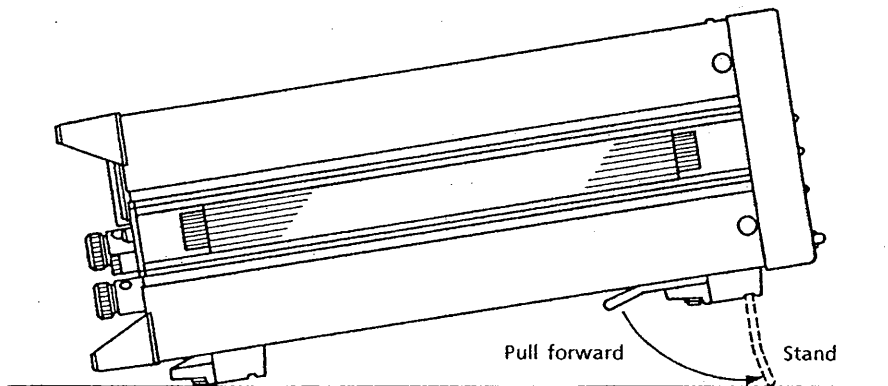

Figure 3.2 Raising the Stand

NOTE

Plastic is used extensively in the case and operating panels of this instrument. Never wipe with light naphtha or mineral spirits, thinner, or chemically-impregnated cleaning cloths.

If the case or panel becomes dirty, wipe gently with a soft cloth.

If the case is heavily soiled, wring out a cloth soaked in a dilute solution of mild detergent, wipe off the dirt, and finish by wiping the instrument dry with a dry cloth.

3.3 Wiring

This section describes wiring for the 2532. The wiring diagrams use power measurement setups as examples. Although voltage and current are therefore both connected, if either voltage or current only is to be measured independently, only the voltage or current wiring need be connected.

 **WARNING**

- ⊙ To prevent an electric shock or a fire, be sure to use power supply cord and 3 to 2 pin adapter supplied by YOKOGAWA. Main power plug must be plugged in an outlet with protective grounding terminal only. Do not invalidate protection by using an extension cord without protective grounding.
- ⊙ Always turn off power to the line to be measured before connecting the line to the instrument.
Be very careful not to connect the voltage circuit to the current input terminal, or to connect the current circuit to the voltage input terminal. A mistake in making this connection not only may burn out the instrument, but also presents serious hazards to personnel.
- ⊙ The input terminal to which the line to be measured is connected is applied with high-voltage, which is dangerous. Avoid all unnecessary contact with the terminal.
- ⊙ It is very dangerous to connect or disconnect wiring to a line whose power switch is ON. Always turn the measured line power OFF when connecting or disconnecting wires.
- ⊙ Regardless of whether the instrument power switch is ON or OFF, applying an input greater than the maximum allowable instantaneous or continuous input specified in Section 1.5, "Specifications", not only may cause damage to the instrument, but also presents serious hazards to personnel.
- ⊙ For connection, use leadwires which:
 - (i) have a withstanding voltage and current capacity that are sufficiently high (e.g. a maximum rating of 600 V at 5 A, cross sectional area of 0.86 mm²) to cope with the voltages and currents being measured, and
 - (ii) have an insulation resistance that is suitable for this rating.
- ⊙ The peeled-off section of leadwire to be connected to an input terminal should be of such a length that no bare wire protrudes from the input terminal after the leadwire has been connected.

NOTE

- © Power measurement often involves the handling of voltages and currents with large current values and high-frequency components. The user must therefore pay close attention to interference and noise reduction considerations when wiring. For high-frequency inputs, stray capacitances between wires and to ground can cause errors, and cannot be ignored. To keep such errors to a minimum, consider the following when wiring.
- Keep wiring as short as possible.
 - To reduce stray capacitance between wires, keep the two leadwires to the voltage input terminals separated.
 - Use large-diameter leadwires for the wiring to the current input terminals.
 - To reduce capacitance to ground, keep the wiring as far separate as possible from grounds and the instrument case.

3.3.1 Single Phase 2-Wire Power Measurement

(1) If Voltage and Current are Both Within the Standard Measurement Ranges

If both the voltage and current are within the measurement ranges indicated by the specifications, securely connect the SOURCE and LOAD wires to the voltage terminals and current terminals on the rear, as shown in Figure 3.3, or on the wiring diagram in the middle of the instrument rear panel. The diagram indicates a thick wire for the current circuit, and a thin wire for the voltage circuit.

If the wiring is connected in this way, the digital values on the display are themselves the measured values.

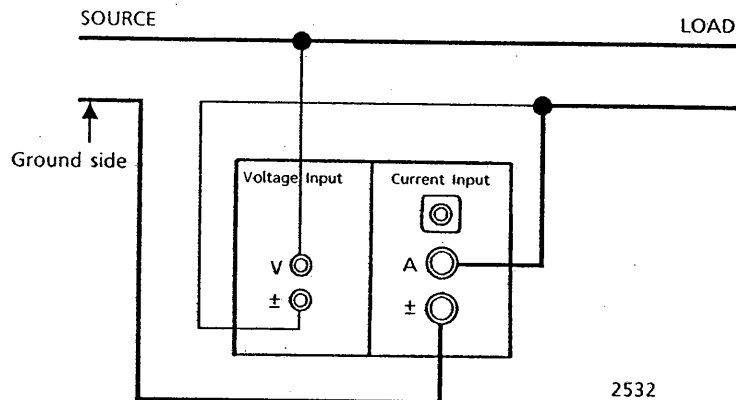

Figure 3.3 Single Phase 2-Wire Wiring

NOTE

- The leadwire from the SOURCE to the \pm current terminal should be connected to that side of the source that is closest to the ground potential. If this is not done, measurement error may increase.

Figure 3.4 shows the internal configuration of the 2532.

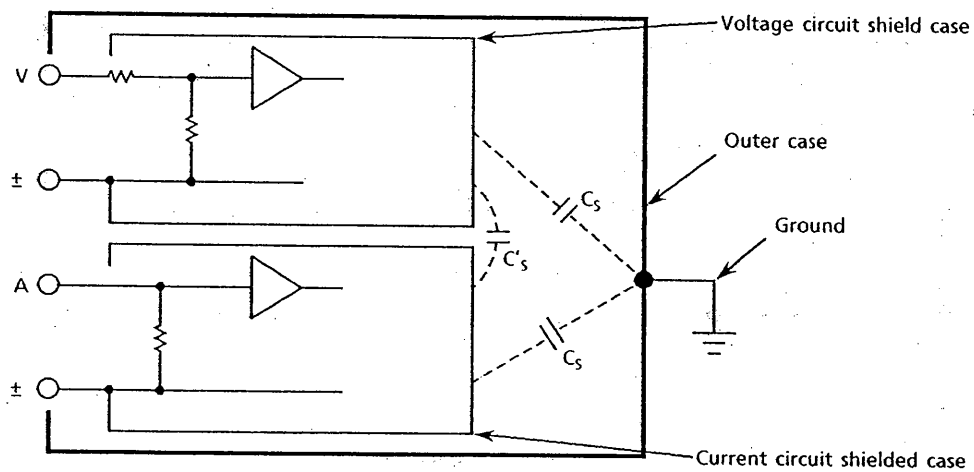

Figure 3.4 2532 Internal Configuration

The voltage circuit is enclosed by the voltage circuit shield case, and the current circuit is enclosed by the current circuit shield case, and both of these are contained within the outer case. The voltage circuit shield case is connected to the voltage \pm terminal, and the current circuit shield case is connected to the current circuit \pm terminal.

There is mutual isolation between:

- the voltage circuit shield case and current circuit shield case, and
- voltage circuit shield case and outer case, and
- current circuit shield case and outer case.

However, stray capacitances C_S and $C'S$ are present. C_S is approximately 100 pF.

With a powermeter that can measure up to high frequencies, such as the 2532, one cannot ignore this stray capacitance, as it may cause an error in the measured values.

For example, assume that as in Figure 3.5 the power supply (source) and outer case are both grounded. If connected (incorrectly) as shown in Figure 3.5, the current " i_L " from the power source enters current terminal "A", passes through the shunt, is output from the current terminal " \pm ", passes through the LOAD, and returns to the power supply as shown by the dotted line. Although this presents no problem, there is an additional current " i_{C_S} ", as indicated by the dot-dashed line, flowing from the power source through the shielding and stray capacitance and back to power source ground.

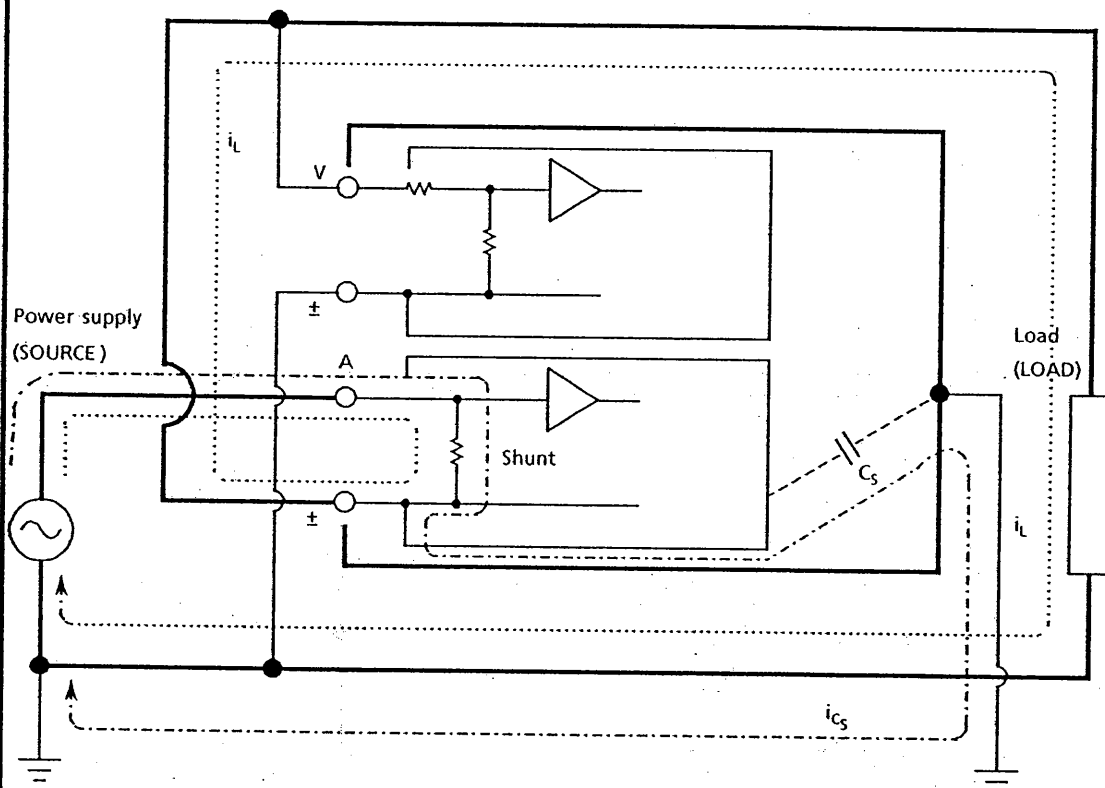

Figure 3.5

As can be clearly seen from this, in a situation where we wish to measure only the load current i_L flowing through the current path, we end up measuring the sum of this (the vector sum) and the current i_{C_S} that flows through the stray capacitance. The current, i_{C_S} , that flows in C_S is determined by the following formula.

If the voltage (common mode voltage) applied to C_S is taken as V_{C_S} , then,

$$i_{C_S} = V_{C_S} \times 2\pi f \times C_S$$

Since in Figure 3.3 the “±” current terminal and the “±” voltage terminal are both at near ground potential, V_{C_S} is nearly 0, and no error results.

For reference, let us compute the effect of the stray capacitance.

Since $C_S = 100 \text{ pF} = 100 \times 10^{-12} \text{ F} = 10^{-10} \text{ F}$

$$\begin{aligned} i_{C_S} [\text{A}] &= V_{C_S} [\text{V}] \times 2\pi f [\text{Hz}] \times C_S = V_{C_S} \times 2\pi f \times 10^{-10} \\ &= 2\pi \times 10^{-4} \times V_{C_S} \times f [\text{kHz}] \quad [\text{mA}] \end{aligned}$$

So, for example, if $f = 100 \text{ kHz}$ and $V_{C_S} = 100 \text{ V}$ then, $i_{C_S} \doteq 6.28 \text{ mA}$, and if we assume $i_L = 1 \text{ A}$,

then because for a resistive load the vector sum will be as in the figure below ($\cos \varphi = 1$)

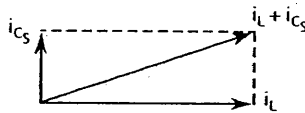

$$\begin{aligned} i_L + i_{C_S} &= \sqrt{1^2 + 0.00628^2} \\ &\doteq 1.00002 \end{aligned}$$

we obtain. Thus the error is 0.002% and the influence can be seen to be quite small.

However, if the load has $\cos \varphi = 0.5$,

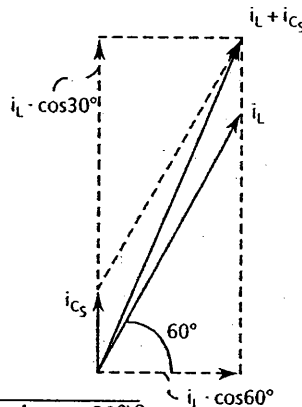

$$\begin{aligned} i_L + i_{C_S} &= \sqrt{(i_L \cos 30^\circ)^2 + (i_{C_S} + i_L \cos 60^\circ)^2} \\ &= \sqrt{(0.866)^2 + (0.00628 + 0.5)^2} \\ &\doteq 1.00313 \text{ A} \end{aligned}$$

Thus the measurement error now becomes 0.313%.

In the case of a load with $\cos \varphi = 0$, the vector sum is simply $i_L + i_{C_S} = 1 + 0.00628 = 1.00628$, and the error is 0.628%.

Since active power is displayed as $W = VA \cos \varphi$, the error in current then appears directly as the error in power.

(2) If Voltage and Current Exceed the Measurement Ranges

The maximum measurement range for this instrument is 600V for voltage, and 5A for current.

Therefore, to measure higher voltages or currents the user must connect an external potential transformer (PT) or voltage divider, and/or an external current transformer (CT).

For safety, use the external PT and CT which are doubly isolated.

Note, however, that the frequency and phase characteristics of an external PT, voltage divider, or CT can affect the measured values.

Figure 3.6 shows an example of external PT and CT use.

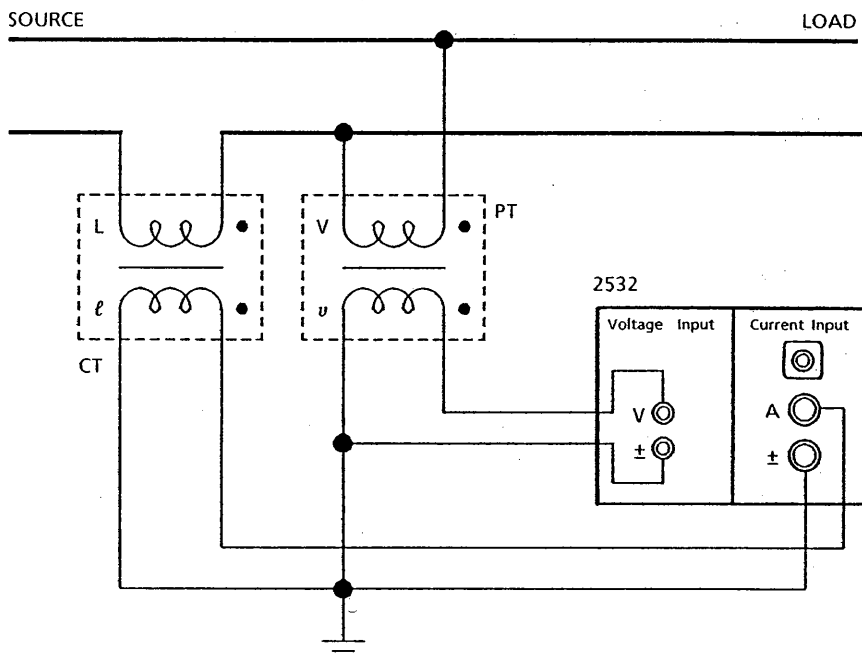

Figure 3.6 External PT and CT Usage Example

Generally, PT secondaries are rated at 110V or 150V, and CT secondaries at 5A, so the user should select units providing the appropriate primary range according to the voltage and current to be measured.

[Calculation Examples When Using PT/CT]

① Voltage measurement (2532 voltage display \times PT transformation ratio)

Example : 2532 voltage display value : 100.00V
 PT transformation ratio : $3300 / 110 = 30$
 Measured voltage value : $100V \times 30 = 3kV$

② Current measurement (2532 current display \times CT transformation ratio)

Example : 2532 current display value : 4.000A
 CT transformation ratio : $50 / 5 = 10$
 Measured current value : $4A \times 10 = 40A$

③ Power measurement (2532 active power display \times PT ratio \times CT ratio)



Example : 2532 active power display value : 350.0W
 PT transformation ratio : $3300 / 110 = 30$
 CT transformation ratio : $50 / 5 = 10$
 Measured active power value : $350W \times 30 \times 10 = 105kW$

- To be able to read the above measured values directly from the display, use the scaling functions to set up the PT ratio and CT ratio.
For details concerning scaling, see Section 3.5.4, "Scaling (SCALING) Factor Setup".

 **WARNING**

- ⊙ NEVER open the secondary circuit of an external current transformer circuit, or in any way allow it to become open, when power is applied to its primary. Opening the circuit will result in extremely high and dangerous voltages being generated across the current transformer secondary winding.
- ⊙ For safety, use the external PT and CT which are doubly isolated.

NOTE

- ⊙ This instrument is designed such that changing ranges via the front panel  and  keys does not create an open-circuit condition in the internal shunt circuits. Thus its construction permits the range to be changed while the circuit under test is energized.
- ⊙ When a potential transformer and current transformer are used for power measurement at low power factors, even their small phase errors will have a large effect on the measured power. If accurate power measurement is required, be sure to use transformers whose transformation ratio and phase errors are sufficiently small to yield the required accuracy.

(3) If Current Exceeds the Measurement Range — Using External Shunts —

If the current to be measured exceeds 5A, a shunt input connector is provided to allow use of a shunt with the required current rating. As when using current transformers, exercise care, since the frequency and phase characteristics of the shunt can affect the measured values. Figure 3.7 shows the method for connecting the shunt.

In this case, do not connect anything to the other current terminals (A, and \pm). Not only may this damage the instrument, it also presents serious hazards to personnel.

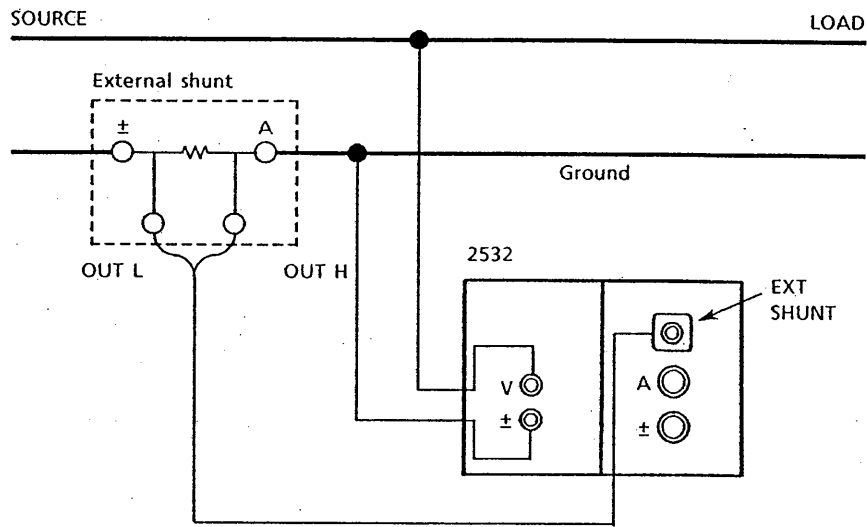
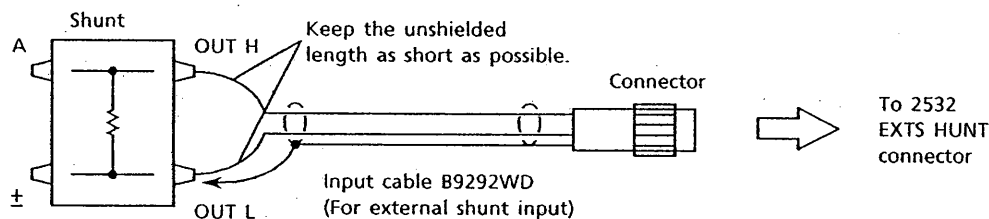

Figure 3.7 External Shunt Connection

Use the accessory external shunt input connector cable (B9292WD) to connect the shunt and the 2532, as shown in Figure 3.8.



Connector number	Wire	Signal
1	White	OUT H
2	—	Not used
3	Shield	OUT L
4	Black	Shield
—	Green	Not used

Figure 3.8

As shown in Figure 3.8, connect the input cable shield to the low side of the shunt output terminals (the OUT L side), which are connected to the input “±” side. Not connecting the shield in this way will increase measurement error.

Since the external shunt input ranges of the 2532 are 50mV, 100mV and 200mV, use shunts whose voltage drops correspond to these ranges.

For example, shunt ratings : 100A/50mV

25A/100mV, etc.

Even if the shunt voltage drop does not match a 2532 range, scaling can be used to achieve proper display correspondence provided that the shunt output voltage is less than 200mV. The user should select from among 50mV, 100mV and 200mV the next higher range above the voltage drop.

 **WARNING**

- ◎ The Yokogawa product number for the external shunt input cable is B9292WD (accessory).
The input cable rating is 300 V (withstanding voltage, 1500 V). Do not exceed this voltage during use. Doing so may result in errors and present hazards to personnel.
- ◎ Always turn the SOURCE power switch OFF before making connections when using an external shunt, since it is dangerous to make connections with circuits energized.
The same care must be taken with respect to the shunt input terminals and output terminals (OUT H and OUT L), since high voltages may be present on them also.
- ◎ High voltages may be present on the shunt. NEVER touch the shunt when the circuit is energized.

NOTE

- ◎ When a shunt is used for power measurement at low power factors, even its small phase error can have a large effect on the measured power. If accurate power measurement is required, be sure to use a shunt whose conversion and phase errors are sufficiently small to yield the required accuracy.
- ◎ Keep the wiring from the line to the shunt input as short as possible. When using an external shunt, keep the wiring from the external shunt output to the 2532 shunt input, too, as short as possible. In either case, long wiring adds to the stray capacitance and lead resistance, both of which increase error.

3.3.2 High-Accuracy Measurement

(1) Recommended Wiring Procedures

The 2532 has been designed with high voltage input impedance and low current input impedance to minimize instrument loss effects on accuracy.

Voltage	: Input resistance, approx. $1.3\text{M}\Omega$ (all ranges), 15pF in parallel	
	Current : Input resistances (approximate)	2Ω on 20mA, 50mA, 100mA ranges
		0.2Ω on 200mA, 500mA, 1A ranges
	0.05Ω on 2A, 5A ranges	

Series inductance $0.4\mu\text{H}$

The wiring diagram below is recommended for connections, and is shown on the rear panel of the 2532.

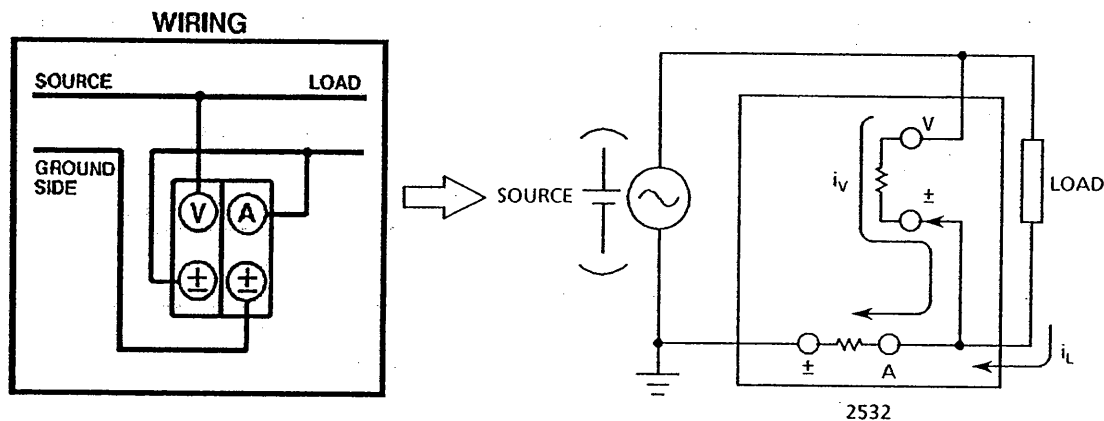

Figure 3.9

In this wiring diagram, the voltage measurement circuit is connected across the load.

The effect of instrument loss on measurement accuracy is most easily illustrated by the case of a DC power source and resistive load. The current measurement circuit will measure the sum of the current i_L flowing in the measured load plus the current i_v flowing in the voltage measurement circuit. Since the measured current itself is i_L , the error will be just i_v .

On the maximum input range of 600V, the 2532 voltage circuit input resistance is $1\text{M}\Omega$, so that the i_v at the maximum 600V input is 0.6mA ($=600\text{V}/1\text{M}\Omega$), and the effect is 0.1% or less for measured currents of 600mA or more (load resistance $1\text{k}\Omega$ or less). Similarly, for a 10V input, the value is 10mA minimum. For reference, the graph that follows shows input voltage and current values for which this effect is 0.1% or less.

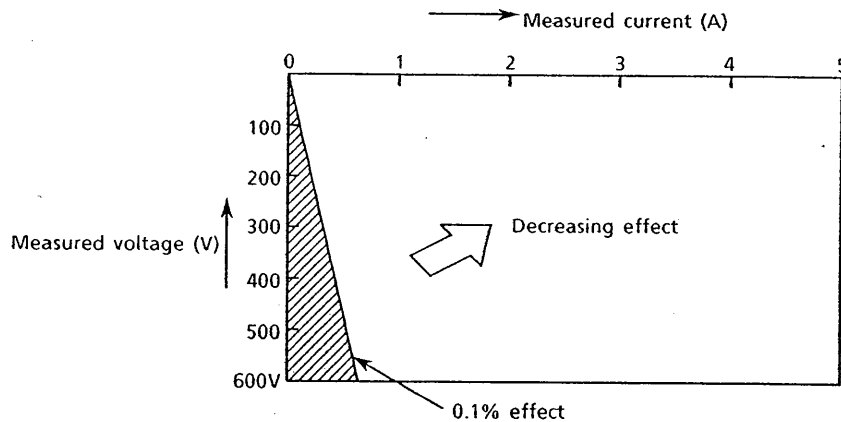

Figure 3.10 Instrument Loss Effect

The graph shows clearly that the recommended wiring diagram gives the best results in the majority of cases. For example, for a 100V, 5A input, the measurement accuracy effect from $i_V = 10\text{mA}$ ($= 100\text{V} / 1\text{M}\Omega$) is only 0.012% ($= 10\text{mA} / 5\text{A}$).

On the other hand, for low measured currents (large load resistance), the measurement accuracy effect increases. In such cases, the current circuit should be connected on the load side as shown below. The voltage circuit will therefore measure the sum of the load voltage, e_L , and the current measurement circuit voltage drop, e_A , and the error will be just e_A . However, since the current circuit input resistance is small, the effect is minimal. For example, if a load resistance of $10\text{k}\Omega$, and 100mA range is used, input resistance is approximately 2Ω , and the measurement accuracy effect is 0.02% ($= e_A / (e_L + e_A)$).

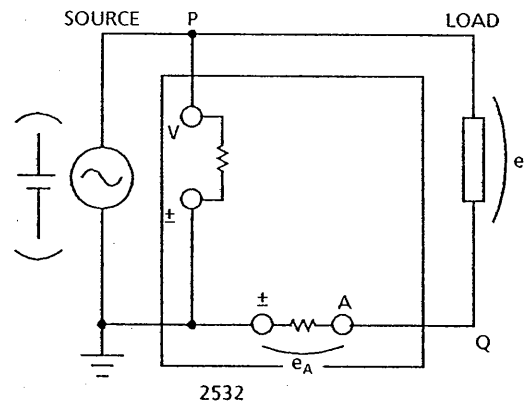

Figure 3.11

As shown above, wiring according to the load resistance reduces measurement accuracy effect due to instrument loss.

(2) Automatic Power Consumption Compensation

Although using the wiring method most suitable for the type of load as discussed in (1) above enables measurements to be made with reduced effects from instrument loss, when even more accurate load power measurements are desired the user can employ a technique called "automatic power consumption compensation," in which the power consumed by the instrument itself is subtracted from the measured value.

If the Voltage Circuit is Connected Closest to the Load

If the connections are made as shown in Figure 3.12 (a), the current flowing through the current terminals will be the sum of the load current, i_L , plus the i_v that passes through the input resistance in the voltage circuit. Thus the powermeter measures the sum of the load power and the power consumed in the voltage input resistance.

Since the power loss at the voltage terminals is nearly the same as the value displayed by the instrument if the load is disconnected without changing the powermeter range, the true load power can be obtained by subtracting this value from the measured values obtained when the load is connected.

Always turn the line power source (SOURCE) OFF, before changing the wiring connections to measure the voltage input circuit loss.

If the Current Circuit is Connected Closest to the Load

If the connections are made as shown in Figure 3.12 (b), the voltage across the voltage terminals will be the drop due to the load, e_L , plus the drop due to the current input resistance, e_A -- in other words, the power source voltage. In this case, if the voltage wiring connection at point "P" is changed to "Q" with the load still connected, as shown in Figure 3.12 (b), the measured power value displayed on the 2532 will indicate the loss at the current terminals. Therefore, the true load power can be obtained by subtracting this value from the power value measured when the voltage connection was at "P".

Always turn the power to the measured line (SOURCE) OFF when making changes to the wiring.

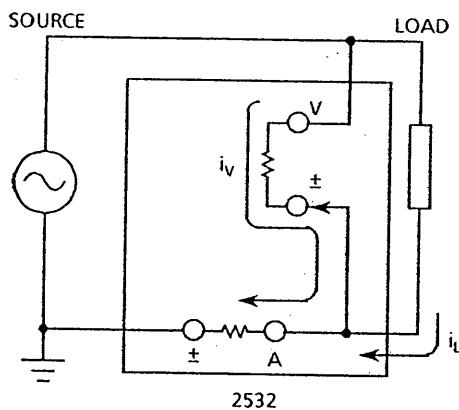

Figure 3.12 (a)

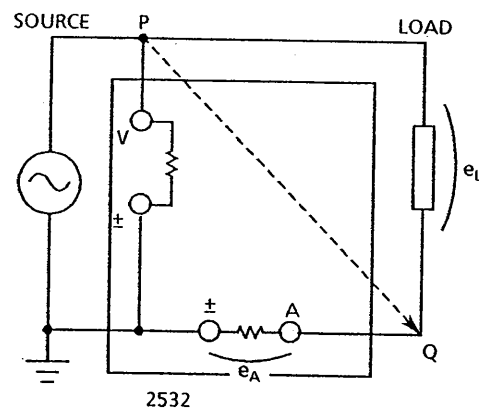

Figure 3.12 (b)

3.3.3 Three Phase 3-Wire Power Measurement

(1) If Voltage and Current are Both Within the Standard Measurement Ranges

To measure 3-phase 3-wire power, use two 2532 instruments according to the two powermeter method, connecting as shown in Figure 3.13.

The sum of the measured values for 2532 (1) and 2532 (2) is the 3-phase 3-wire power value.

The wiring method shown in Figure 3.13 results in connections that do not follow the guidelines in CAUTION item (b) in Section 3.3.1 (1) (which suggest that the "±" terminals always be connected to the low side); see the discussion under that item concerning the error effects that may result.

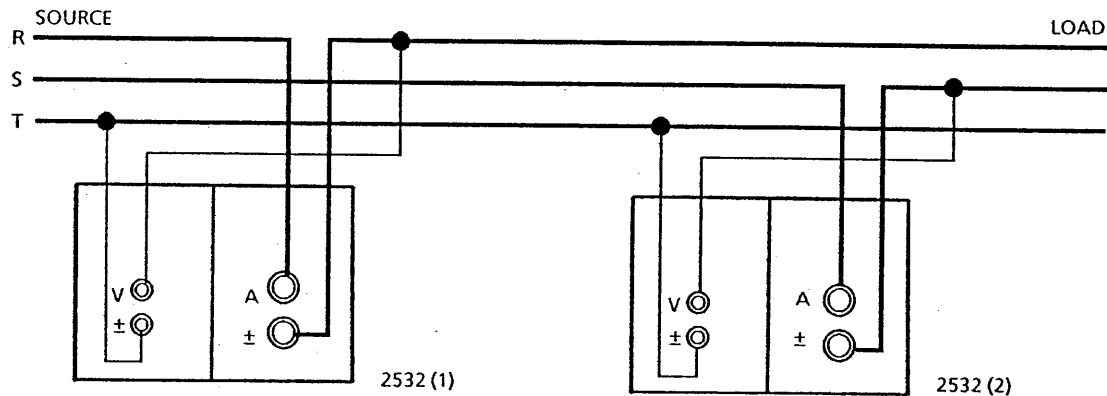

Figure 3.13

(2) If Voltage and Current Exceed the Measurement Ranges

As in single phase measurement, an external potential transformer (PT) and / or an external current transformer (CT) can be used for measurement.

In this case the current range restrictions described in Section 3.3.1 (1) do not apply, but since the frequency and phase characteristics of the external PT and / or CT affect the measured values, the PT and / or CT used should have frequency and phase characteristics that yield sufficiently low errors.

When using a PT and / or CT, read Section 3.3.1 (2) as well.

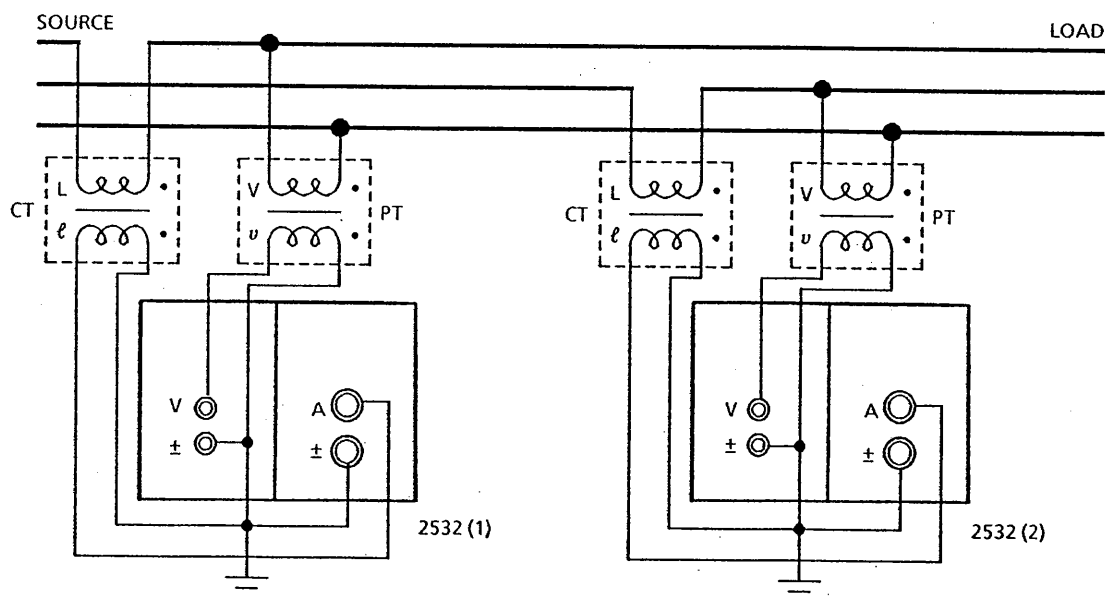

Figure 3.14

(3) If Current Exceeds the Measurement Range — Using External Shunt —

If the current exceeds the maximum measurement range, an external shunt can be used. Since the frequency and phase characteristics of the shunt can affect the measured values, the external shunt used should be selected to have adequate frequency and phase characteristics.

See Section 3.3.1 (3) concerning shunt connection, and 2532 setup and cautions.

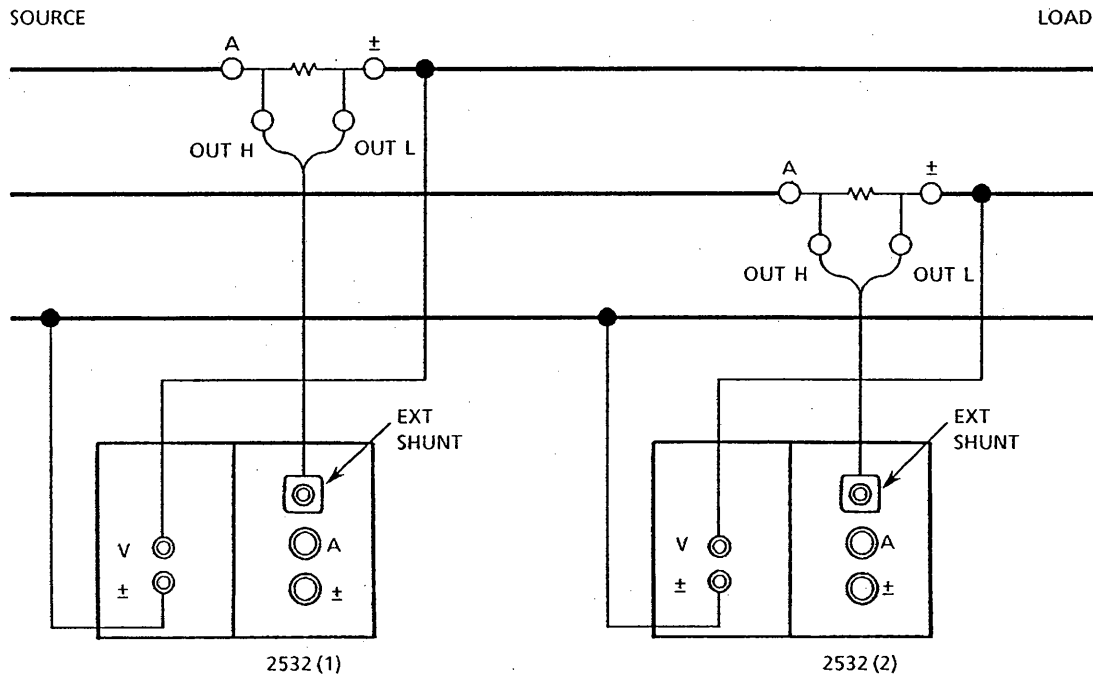

Figure 3.15

The wiring method shown in Figure 3.15 results in connections that do not follow the guidelines in CAUTION item (b) in Section 3.3.1 (1) suggesting that “±” terminals always be connected to the low side; see the discussion under that item concerning the error effects that may result.

3.3.4 Three Phase 4-Wire Power Measurement

(1) If Voltage and Current are Both Within the Measurement Range

To measure 3-phase 4-wire power, use three 2532 instruments according to the three powermeter method, connecting them as shown in Figure 3.16.

The sum of the measured values of powermeters 2532 (1) through 2532 (3) is the 3-phase 4-wire power value.

The wiring method shown in Figure 3.16 results in connections that do not follow the guidelines in CAUTION item (b) in Section 3.3.1 (1) suggesting that "±" terminals always be connected to the low side; see the discussion under that item concerning the error effects that may result.

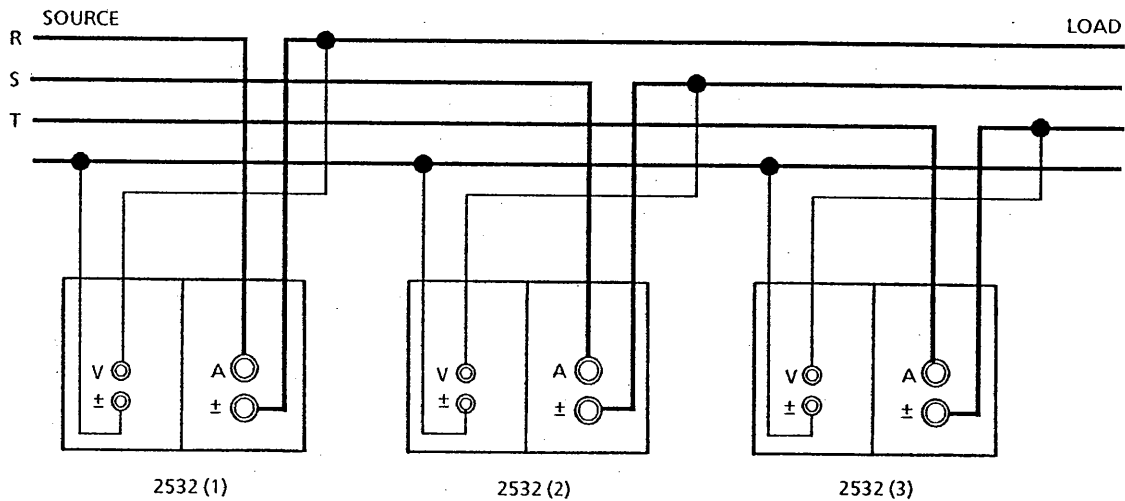

Figure 3.16

(2) If Both Voltage and Current Exceed the Measurement Range

As for single phase measurement, an external potential transformer (PT) and / or an external current transformer (CT) can be used for measurement.

In this case the current range restrictions described in Section 3.3.1 (1) do not apply, but since the frequency and phase characteristics of the external PT and / or CT affect the measured values, the PT and / or CT used should have frequency and phase characteristics that yield sufficiently low errors.

When using a PT and / or CT, read Section 3.3.1 (2) as well.

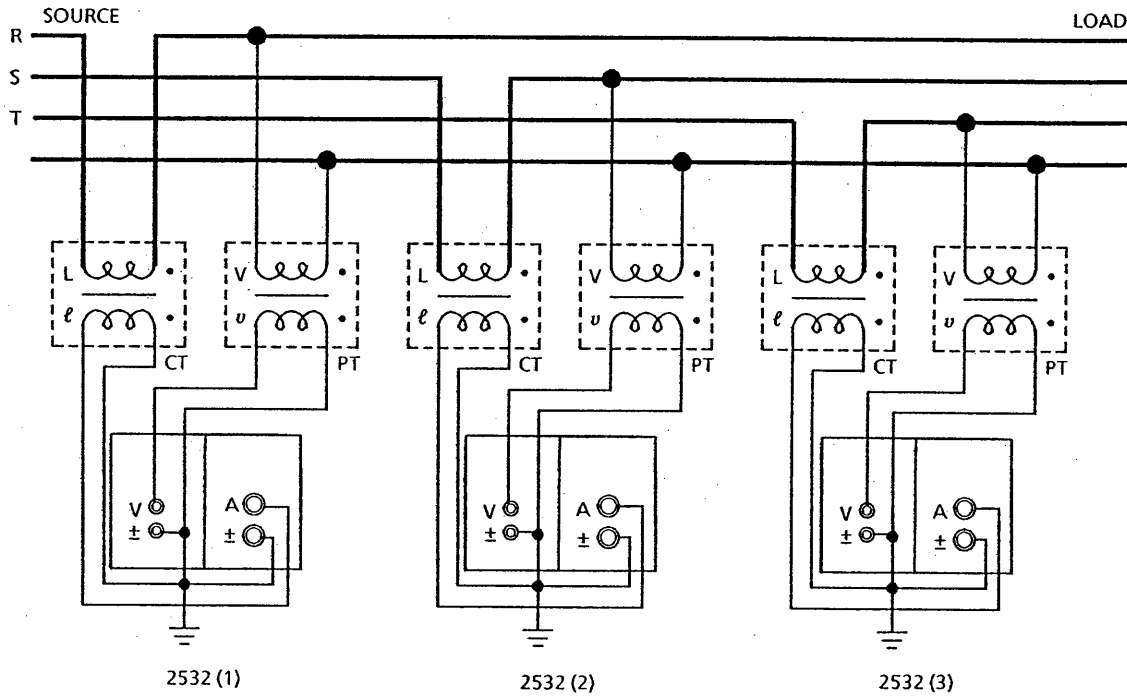

Figure 3.17

(3) If Current Exceeds the Measurement Range

As for single phase, external shunts can be used. Since the frequency and phase characteristics of the shunt can affect the measured values, the external shunts should be selected to have adequate frequency and phase characteristics.

See Section 3.3.1 (3) concerning shunt connection, and 2532 setup and cautions.

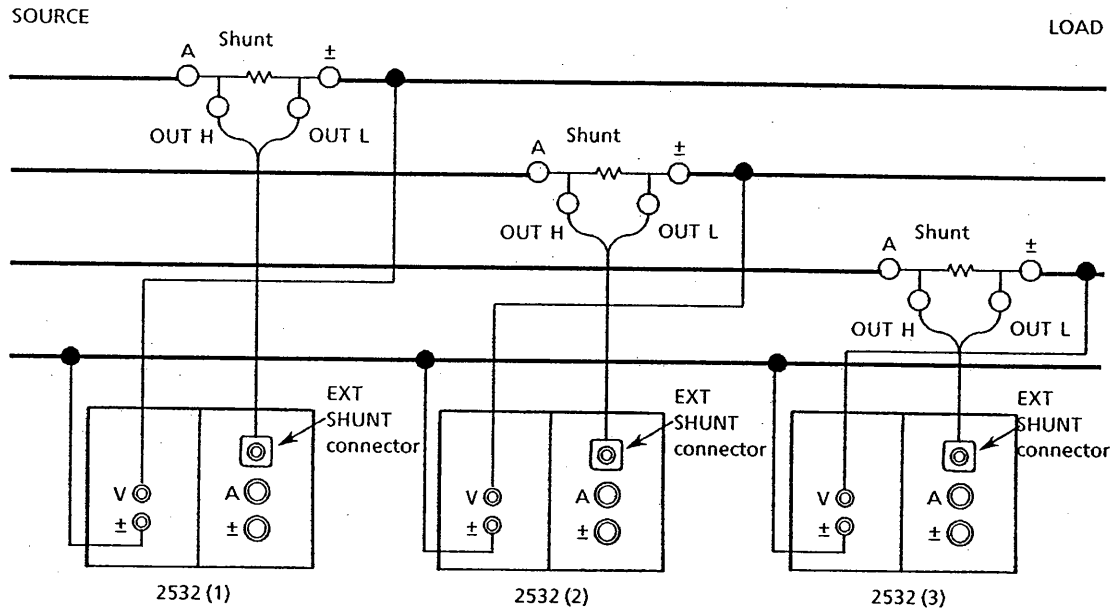

Figure 3.18

The wiring method shown in Figure 3.18 results in connections that do not follow the guidelines in CAUTION item (b) in Section 3.3.1 (1) suggesting that "±" terminals always be connected to the low side; see the discussion under that item concerning the error effects that may result.

3.4 Power - ON

(1) Key Setup Status at Power - ON

This instrument is equipped with a battery to backup the panel setup information, which is preserved in the internal memory just as it was at the last time when power was turned OFF.

When power is turned ON, the setup status is read out from the internal memory, restoring the setup information in effect when power was turned OFF.

Note that when the panel setup information backup battery is low, error code 60 (**Err 60**) appears in the opening messages at power - ON.

NOTE

If the setup information has been backed up by means of the "panel setup information backup battery", then the setup status of each individual key when the power is turned ON will be the same as the last time when power was turned OFF. However, certain status information for the GPIB and RS-232-C interfaces (models 253221 and 253222, respectively) is not preserved in that manner, namely the service request mask, ":IM**", and output data terminator, ":DL**".

In this case, set the function of DISPLAY C to Wh or Ah and press the integrator RESET key to release the integration mode. Then, use the instrument. Otherwise, pressing any of these keys displays "Err 13" since some keys are protected in integration.

3.5 Individual Key Setup Procedures

Since basic functions and operations for each of the keys are described in Section 2, here we will describe primarily the procedures for setting up the individual parameters.

3.5.1 Voltage / Current Range Setup

(1) Setup Key and Range Indicators

The voltage and current ranges are set up using the keys shown in Figure 3.19 and Figure 3.20, respectively. The range that has been selected can be identified by the range indicator LED that is lit.

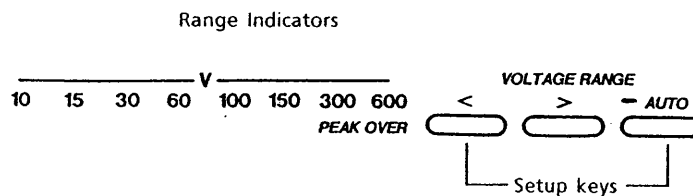

Figure 3.19 Voltage Range Setup Keys and Range Indicators

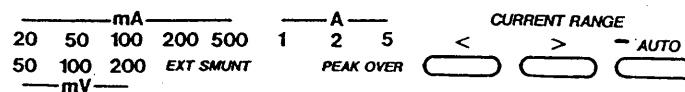

Figure 3.20 Current Range Setup Keys and Range Indicators

For details, see ⑫ and ⑭ in Section 2.1.

(2) Power Range

The power range is determined by the voltage and current range combination as follows.

$$\langle \text{Power range} \rangle = \langle \text{Voltage range} \rangle \times \langle \text{Current range} \rangle$$

Example: If a 100V range and a 5A range are combined, the power range is 500W.

(3) Range Selection Methods

Range selection methods include the automatic range selection mode and the fixed range selection mode.

In the case of the automatic range mode, the range changes as shown below.

① Range is Increased When:

- Measured value exceeds 110% of the range.
- Peak level exceeds 350% of range for either voltage or current.

② Range is Decreased When:

Measured value falls below approximately 30% of the measurement range.

NOTE

- When using auto range to measure a waveform with a large crest factor (3.5 or above), or to measure a signal of 10Hz or less, auto range selection may fail. If that happens, use fixed range mode.
- Since auto range selections change according to the rules described in ① and ② above, the range may differ for the same input value, depending on preceding measurements.
- If a measured value exceeds 110% of range in auto range, the time required for the range to change is the same as the display update interval.

3.5.2 Digital Display (DISPLAY)

This instrument has three digital displays, DISPLAY A, DISPLAY B, and DISPLAY C, as shown in Figure 3.21, making it possible to display three types of parameters, such as voltage, current, and power, at the same time.

These displays are also used to set up scaling factors, the integration timer, memory card mode, interface addresses, and baud rate.

See ② in Section 2.1 for the contents of each display.

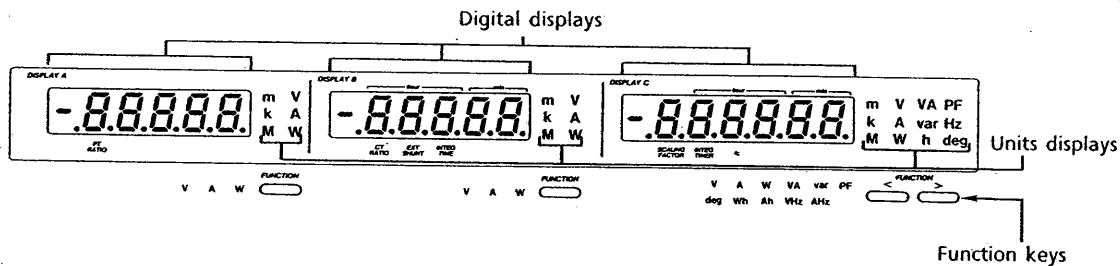

Figure 3.21 Digital Displays and Function Keys

(1) Digital Display Specifications

Display Ranges

DISPLAY A, DISPLAY B ; 0.0000 to ± 1400

Except DISPLAY B as timer display ; 00000 to ± 99999

DISPLAY C ; 0.00000 to ± 999999

- ① For display of voltage (V) or current (A) value, if measured value is less than 0.1% of range, "0" (zero) is displayed.

Measured Value Overage Display :

Fixed rang ; If value exceeds 140% of rated range

Automatic range ; If value exceeds 140% of maximum range

Computed Value Overflow Display :

No Data :

(2) Measured / Computed Value Display

Table 3.1

① Voltage (V) Display

Display Voltage range	Rated display	Maximum display
10V	10.000	14.000
15V	15.00	21.00
30V	30.00	42.00
60V	60.00	84.00
100V	100.00	140.00
150V	150.0	210.0
300V	300.0	420.0
600V	600.0	840.0

② Current (A) Display

Display Current range	Rated display	Maximum display
20mA	20.00	28.00
50mA	50.00	70.00
100mA	100.00	140.00
200mA	200.0	280.0
500mA	500.0	700.0
1A	1.0000	1.4000
2A	2.000	2.800
5A	5.000	7.000
*50mV	10.000A	14.000A
*100mV	10.000A	14.000A
*200mV	10.000A	14.000A

* Shunt input range for 10.000A EXT SHUNT setting

- Although the nominal input range is 10% to 110% of the range, the display can indicate up through 140% of range (maximum display). At 0.1% of range or below, the display changes to zero.

③ Active Power (W), Apparent Power (VA), and Reactive Power (var) Display

Table 3.2 For Rated Inputs

		Current input A								EXT SHUNT
		20.00mA	50.00mA	100.00mA	200.0mA	500.0mA	1.0000A	2.000A	5.000A	*10.000A
Voltage input V	10.000V	200.0m	500.0m	1.0000	2.000	5.000	10.000	20.00	50.00	100.00
	15.00V	300.0m	750.0m	1.500	3.000	7.500	15.00	30.00	75.00	150.0
	30.00V	600.0m	1.500	3.000	6.000	15.00	30.00	60.00	150.0	300.0
	60.00V	1.200	3.000	6.000	12.00	30.00	60.00	120.0	300.0	600.0
	100.00V	2.000	5.000	10.000	20.00	50.00	100.00	200.0	500.0	1.000k
	150.0V	3.000	7.500	15.00	30.00	75.00	150.0	300.0	750.0	1.500k
	300.0V	6.000	15.00	30.00	60.00	150.0	300.0	600.0	1.500k	3.000k
	600.0V	12.00	30.00	60.00	120.0	300.0	600.0	1.200k	3.000k	6.000k

* Shunt input range for 10.000A EXT SHUNT setting

④ Power Factor (PF) Display

Display range is -1.000 to 1.000

Display when computation results exceed "1.000":

Computation results	Display
1.001 to 2.000	1.000
2.001 or more	PFErr

Phase lead (*d*) or phase lag (*G*) is indicated ahead of the power factor (the symbols approximate the final letters of "lead" and "lag").

(Display example: *d 0.987*)

If the voltage or current input is less than 30% of the rated value, phase lead/lag detection is not performed, and not displayed.

⑤ Phase Angle (deg) Display

Display range is 0.0 to 180.0 deg

If the power factor (PF) computation result exceeds "2.000", "*dEUErr*" is displayed to indicate error.

Phase lead (*d*) or phase lag (*G*) is displayed before the phase angle. (Display example: *G 41.3*)

If the voltage or current input is less than 30% of the rated value, phase lead/lag detection is not performed, and not displayed.

⑥ Frequency (Hz) Display (option)

Display range for a display update interval of 0.4s is 20.00Hz to 1000.0kHz

For a display update interval of 1.6s, 2.000Hz to 100.00kHz

⑦ Power Integration (Wh), Current Integration (Ah) Display

Display range is "*-999999* to *999999*" (6 digits)

If the integration value goes over the maximum display value, the elapsed time (DISPLAY B) is preserved, and integration stops. In this case, the integration value is held.

(3) Digital Display Selection

Use the function keys in Figure 3.22 to select the measured value or computed value to be displayed in DISPLAY A, DISPLAY B, and DISPLAY C of the digital display.

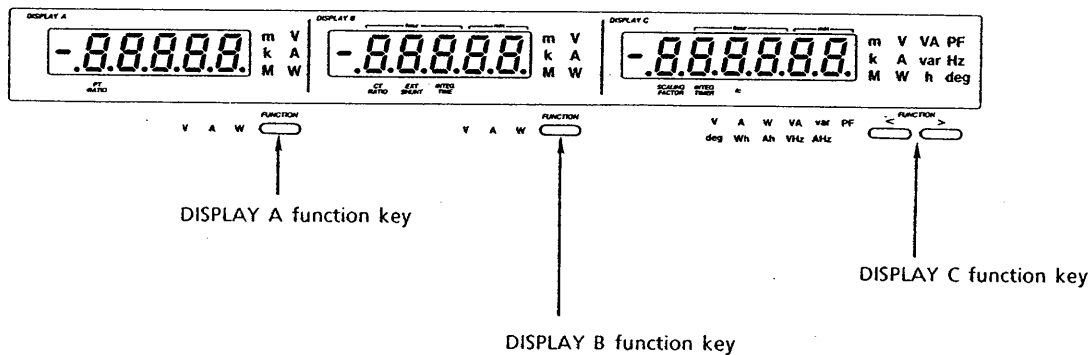

Figure 3.22 Function Keys

Table 3.3 shows the functions and the respective information displayed.

Table 3.3 Functions and Information Displayed

Function	Display	Function	Display
V	rms voltage *	deg	Phase angle
A	rms current	Wh	Integrated active power (energy)
W	Active power	Ah	Integrated current
VA	Apparent power	VHz (option)	Voltage input frequency
var	Reactive power	AHz (option)	Current input frequency
PF	Power factor		

* There are two possibilities for rms voltage - true rms value, and rms-calibrated average rectified value - either of which can be selected by the front panel keys.

Apparent power VA, reactive power var, power factor PF and phase angle deg are obtained by V, A and W values. Carefully note that value V for distorted wave signal differs from true r.m.s. value with voltage V set to the rms calibrated average rectified value (MEAN) mode.

When obtaining VA, var, PF and deg, measure voltage V in the RMS mode.

3.5.3 Measurement Mode Selection

The keys shown in Figure 3.23 are used to specify whether or not scaling, averaging, and integration will be performed.

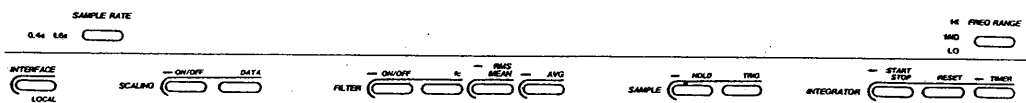

Figure 3.23 Measurement Mode Selection Keys

For the functions and factors that are set with each key, see ②, ④, ⑦, ⑧, ⑩, ⑪, and ⑬ in Section 2.1, Section 3.4, “Power-ON”, and Section 4, “Functional Description”.

FREQ RANGE LO, MID, and HI are used to change the measurement frequency range, and bear the following relationship to the display update interval (SAMPLE RATE).

Table 3.4

Function	Display update interval (SAMPLE RATE)	FREQ Range	Measurement frequency range
Functions other than Wh or Ah	0.4s	LO	DC, 100Hz~10kHz
		MID	DC, 1kHz~80kHz
		HI	DC, 5kHz~400kHz
	1.6s	LO	DC, 20Hz~10kHz
		MID	DC, 200Hz~80kHz
		HI	DC, 2kHz~400kHz
Wh, Ah	1.0s	LO	DC, 20Hz~16kHz

3.5.4 Scaling (SCALING) Factor Setup

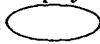
In this instrument, scaling factors can be set up for the voltage, current, and power measured values. Since external potential transformers (PT), current transformers (CT), and external shunts can be used to measure inputs beyond the measurement range, this function is useful in that it allows the measurements to be scaled so that they can be read in terms of primary-side values. Scaling of power (SCALING FACTOR) can be used to convert measurements to different physical units, for example, to calorie values. Scaling factors are set up using the keys  encircled in Figure 3.24.

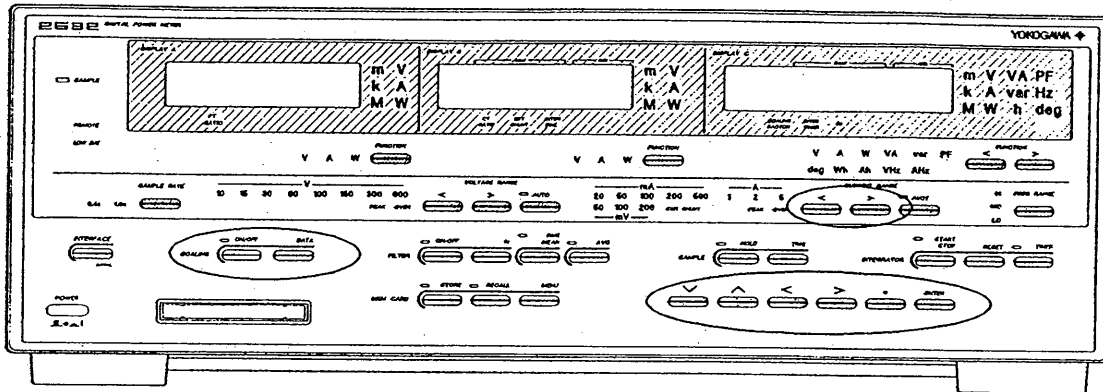

Figure 3.24 Scaling Factor Setup keys

If we take :

- K_V (PT RATIO) as the voltage scaling factor,
- K_I (CT RATIO) as the current scaling factor,
- K_W (SCALING FACTOR) as the power scaling factor,
- and K_S (EXT SHUNT) as the external shunt current factor,

then the display for each function is as follows.

	<u><Measurement data></u>	<u><Scaling data></u>
Voltage	V	$K_V \times V$
Current	A	$K_I \times A (\times K_S)$
Active power	W	$K_V \times K_I \times K_W \times W (\times K_S)$
Apparent power	var	$K_V \times K_I \times K_W \times \text{var} (\times K_S)$
Reactive power	VA	$K_V \times K_I \times K_W \times \text{VA} (\times K_S)$

Where, $(\times K_S)$ is the EXT SHUNT range

(1) Scaling Factor Ranges and Initial Values

The following shows the ranges within which scaling factors can be set.



Table 3.5 Scaling Factor Ranges and Initial Values



Parameter	Range	Initial value
PT RATIO	0.0001 ~ 10000	1.0000
CT RATIO	0.0001 ~ 10000	1.0000
SCALING FACTOR	0.0001 ~ 10000	1.0000
EXT SHUNT	0.0200 ~ 100.00A	10.000A

If a value is set that is outside of the allowed range, "Err 12" appears in DISPLAY C.

If this happens, pressing the ENTER key will cause the digits to begin flashing again, and make it possible to set the value again.

(2) Setup Procedures (If Using External PT or CT)

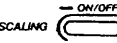
- (a)    AUTO Select one of the current ranges, 20mA to 5A (excluding EXT SHUNT 50mV to 200mV ranges).





- (b)   Press the DATA key.

It does not matter whether SCALING is ON or OFF. Pressing the DATA key changes the display as shown below (displays the initial values).



First digit in DISPLAY A is flashing.

- (c) Set the PT ratio (DISPLAY A).

Use the cursor keys and decimal point key (    ) to set the desired number for each digit (parameter range, 0.0001 to 10000).

After the value and decimal point have been set, press the ENTER key to store to the internal memory.

- (d) Set the CT ratio (DISPLAY B) and scaling factor (DISPLAY C)

Pressing the ENTER key moves operation to the next display, and causes its first digit to begin flashing. Enter the B and C scaling values by the same procedure as in (c) above.

Entering the scaling value in DISPLAY C (pressing the ENTER key) takes the 2532 out of scaling setup mode, and returns the instrument to normal operation.

If no change is required, press the ENTER key.

- (e) If SCALING is set to ON, the factors are placed in effect and the scaled values are displayed.

You should use fixed voltage and current ranges matching the secondary ratings of the selected PT and CT.

See ⑨ in Section 2.1 for cursor key functions.

(3) Setup Procedures (If Using External Shunt)

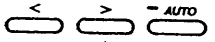
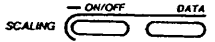
- (a)  Select one of the current ranges: EXT SHUNT 50mV to 200mV.
- (b)  Press the DATA key.



First digit flashing

Otherwise, this is the same as in (2) (b).

(c) Example of EXT SHUNT scaling value setup (when EXT SHUNT range is 50mV)

- Shunt used: 30A/50mV

• Setting: 

If the secondary rating of the external shunt is not 50mV, 100mV, or 200mV, the scaling function can be used to correct this. The following shows an example.

Example: When using a 50A/60mV rated shunt

$$(50/60\text{mV}) \times 50\text{mV} = 41.666 \dots$$



Scaling value is set to 41.67.

In this case, since the selected range is 50mV, obey the allowable input range limits (0mV to 55mV).

(d) When SCALING is OFF, the current display is scaled using this setting.

Note that if SCALING is set to ON, the current scaling factor, K_i (CT RATIO) is also imposed. Normally, set K_i to 1.0000 when using the external shunt scaling factor.

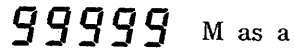
(4) Notes Concerning Scaling Factor Setup

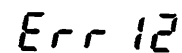
- If the computation results when scaling is set to ON exceeds  M as a result of the scaling value that has been set, the measured data is not displayed, and the display shows .
- If a factor that is outside of the allowed range is set up, pressing the ENTER key will cause  to be displayed; and pressing the enter key again will cause the digit that was flashing before to resume flashing. Correct the setting to a value within the allowed range.
- If the voltage range or current range is changed, scaling is performed on the measured values of the new range. For most accurate measurement, use the nearest range smaller than the rated value of the PT or CT secondary rating, or external shunt rated value.
- Even if the power scaling factor, K_w , is something other than 1.0000, the "W", "VA", and "var" units are still displayed when scaling is ON. In this case, mentally replace these with the desired units.

3.5.5 Filter Cutoff Frequency (fc) Setup

To measure a switching waveform such as that from an inverter, etc., a low-pass filter is inserted to measure the power of the fundamental component.

The filter also can be used in frequency measurement to cancel noise components.

The low-pass filter cutoff frequency (-24dB/oct , -60dB max.) can be selected from the following five choices:

250Hz, 500Hz, 1000Hz, 2000Hz, USER

If USER is selected, any cutoff frequency in the range from 250Hz to 2000Hz can be selected (resolution: 1Hz).

(1) Parameter Range and Initial Values

Table 3.6

Menu	Frequency (Hz)
250	250
500	500
1000	1000
2000	2000
USER (USER)	Any frequency from 250Hz to 2000Hz

Initial value: 2000 Hz

(2) Setup Procedure

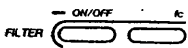
- (a)  Press the fc key to change to setup mode.



Press the fc key causes the display to change as follows.

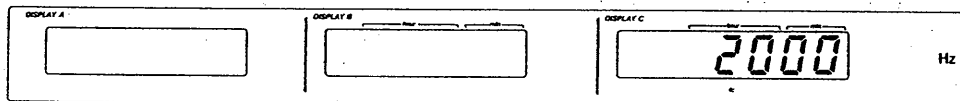

(b) Select the desired cutoff frequency.

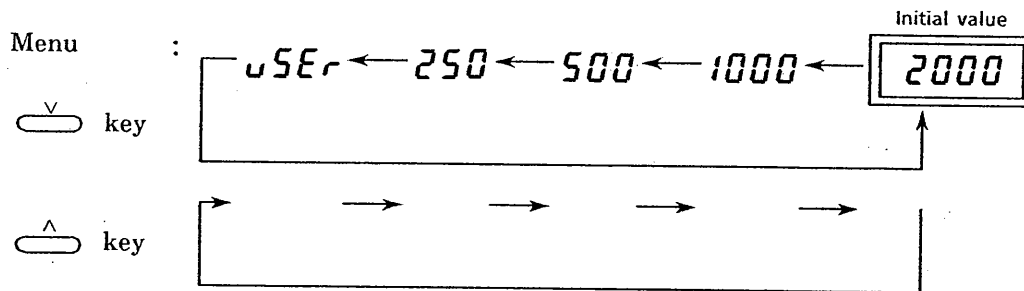

Each time the \downarrow (down) key is pressed, the setting changes as shown in the figure above.

Pressing the \uparrow (up) key moves in the opposite order.

(c) Enter the cutoff frequency.

When the desired frequency is on display, press the ENTER key to enter the fc.

If USER is used to enter the fc, the frequency is entered using the procedure in (d).

Using the ENTER key to enter the fc returns the instrument from the fc setup mode to normal operation.

(d) Set the fc value.

If USER is entered in (c) (by pressing the ENTER key), the display changes as shown in the figure below.

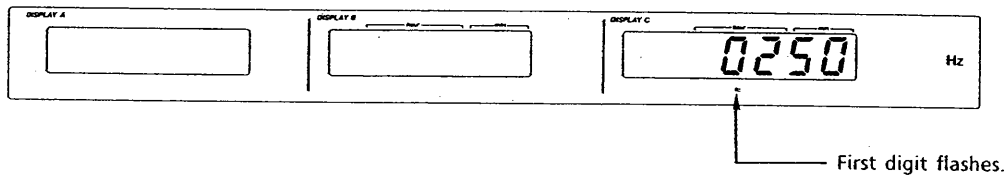

Use the \downarrow and \uparrow keys to select a number (0 to 9) for the digit that is flashing.

Use the \leftarrow and \rightarrow keys to move to the digit to be set (the digit that is selected and is flashing).

After completing the fc setup, use the ENTER key to put the settings into effect.

Note 1 : The cutoff frequency, fc, can be set in the range from 250Hz to 2000Hz, in 1Hz increments.

Note 2 : If an fc outside of the setting range is set, error code 12 (*Err 12*) is displayed in DISPLAY C.

3.5.6 Integration Timer Setup

The integrator function has the following two modes.

- (1) Manual integration mode (timer setting: 00000)
- (2) Standard integration mode (timer setting: 00001 to 100000)

If the integration timer is set to a value between 00001 (1 minute) and 10000 (100 hours), standard integration mode is selected.

This section describes only the procedure for setting the timer time. For details concerning the integrator function, see Section 4.5.

(1) Timer Settings and Display Resolution

Table 3.7 shows timer settings and resolution relative to the rated W/A display.

Table 3.7

Timer setting (hour : min)	Resolution relative to rated W/A display	
00:01 ⋮ 01:00	Times 10	Decimal point position and coefficient are decided so that the integration result will not exceed 200000 (ignoring the decimal point) within one hour at the rated input value.
01:01 ⋮ 10:00	Times 1	Decimal point position and coefficient are decided so that the integration result will not exceed 20000 (ignoring the decimal point) within one hour at the rated input value.
10:01 ⋮ 100:00	Times 0.1	Decimal point position and coefficient are decided so that the integration result will not exceed 2000 (ignoring the decimal point) within one hour at the rated input value.



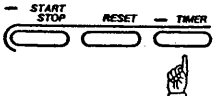

Manual STOP and START is permitted while integration is in progress. In this case, the time during which integration is stopped is not counted, and only the time during which integration is actually performed is displayed.

(2) Setup Procedure

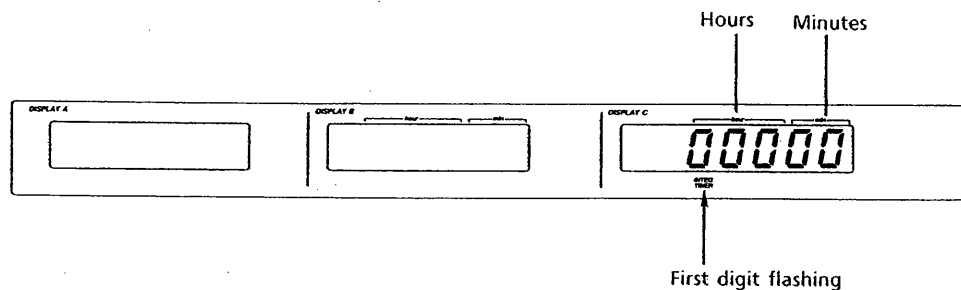

- (a)  Press the INTEGRATOR TIMER key.



This changes to the integration timer setup mode (INTEG TIMER LED turns on).



- (b)   Set the number for the digit that is flashing.
-  key: Decreases number by one (0→9→8→...→1→0)
-  key: Increases number by one (0→1→2→...→9→0)

The number cycles back to 0 at the end of its range.

-   Changes the digit to be set.

- (c)   key: Moves to the left,  key: Moves to the right
- Enters the integration timer setting.

When the desired time has been set, press the ENTER key to enter the timer setting.

Pressing the ENTER key also transfers the instrument from the integration timer setup mode to normal operating mode.

If the FUNCTION in DISPLAY C is set to Wh or Ah, or if the DISPLAY C FUNCTION is Wh or Ah, entering the integration timer setting (pressing the ENTER key) transfers the instrument to the integration START wait mode (display). At this time, DISPLAY C displays " - - - - - ".

Integration START wait mode



Press the INTEGRATOR START key to start integration.

Integration start (START)

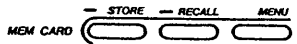

3.5.7 Memory Card Operating Mode Setup

The following functions can be selected using the MEM CARD STORE, RECALL, and MENU keys ().

- Store function : Stores measured data to the memory card.
- Recall function : Retrieves data previously stored to the memory card.
- Operating mode selection : Using the MENU key, the following operating modes can be selected.

- (1) Store mode **St** (ST)
- (2) Recall mode **rE** (RE)
- (3) NS value setup **nS** (NS)
- (4) Data recall starting position setup **rd** (RD)
- (5) Panel setup information save **SS** (SS)
- (6) Panel setup information load **SL** (SL)
- (7) Memory card initialization **[,** (CI)
- (8) Panel setup initialization **r[** (RC)

For details concerning these functions, see Section 4.4, "Store Function and Recall Function". Here we will describe only the principle key setup procedures.

(1) Store/Recall Mode Setup Procedures

- (a)  Press the MENU key.

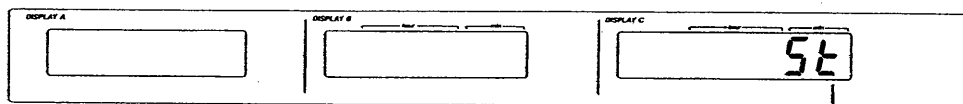



Last digit flashing

Note : Pressing the MENU key a second time at this point will cancel the mode setup, and transfer the instrument to normal measurement mode.

- (b)   are used to select the mode.

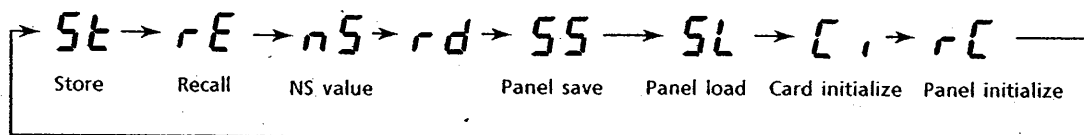
Each time the  key is pressed the display in DISPLAY C moves through its cycles as shown in the figure below.





Pressing the  key cycles the display in the reverse order.

Use the  and  keys to select the desired mode.

(c)  enters the mode.

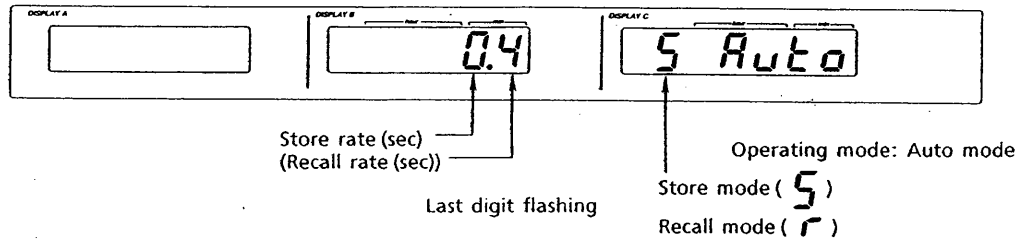
Pressing the ENTER key with the desired mode displayed enters the mode.
If the store (or recall) mode is entered, the display changes as shown below.



(d)  and  Store (or load) rate selection: Display units are seconds (s).

- Store rate (with display update interval of 0.4s, except in integration mode)

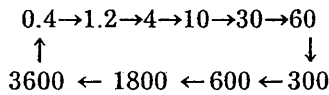

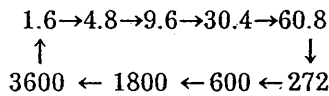

- Store rate (with display update interval of 1.6s, except in integration mode)

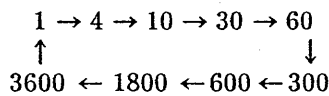

- Store rate (in integration mode)





Each time the  key is pressed, the store rate changes as shown in the figures above.

Pressing the  key changes the rate in the reverse order.

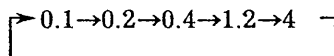
- Recall rate







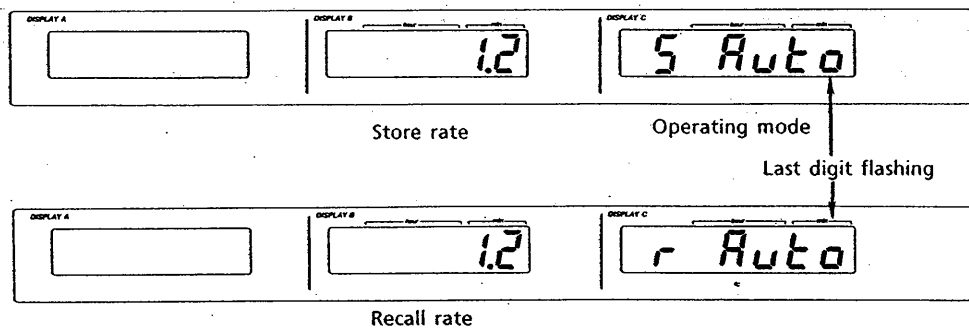

Each time the  key is pressed, the recall rate changes as shown in the figure above.

Pressing the  key changes the rate in the reverse order.

(e)  enters the store (or recall) rate





Pressing the ENTER key with the desired rate displayed enters the rate.
When the rate is entered, the display changes as shown in the figure below.







- (f)  and  are used to set the operating mode
 Use the  and  keys to select auto mode or N reading mode.
 (Auto mode displays, *Auto* N reading mode displays *nr dG*)
- (g)  enters the operating mode.
 With the desired mode displayed on DISPLAY C, press the ENTER key to enter that operating mode.



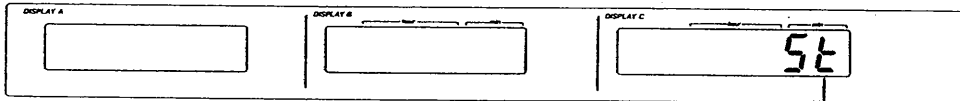

(2) NS Value Setup





- (a)     Press the MENU key.





- (b)  /  , and  are used to select the NS value setup mode and to enter the selection.



Use the  and  keys to select *ns* , and then press the ENTER key to enter that setup mode.



- (c)     , and  are used to set and enter the NS value

Use the  and  keys to select the digit to be changed.

The digit that has been selected will flash.

Use the  and  keys to set a number for that digit.

With the desired NS value set, press the ENTER key to enter.



(NS value setting range : 0001 to 3800). If you attempt to enter a value outside of this setting range, error code 12 (*Err 12*) is displayed; re-set the value.

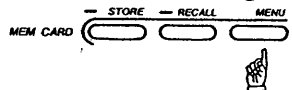

Entering the NS value ends the setup mode, and returns the instrument to normal operation.

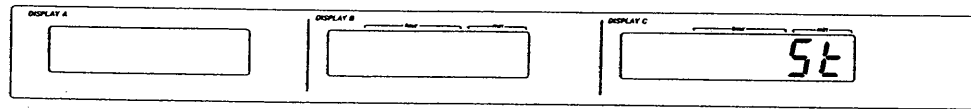
(3) Data Recall Starting Position (rd) Setup

- (a)  Press the MENU key.



- (b)  , and  are used to select and enter the rd mode.

Use the  and  keys to select *rd* (DISPLAY C display), and then press the ENTER key to enter the rd mode, and to move to the mode for setting the data recall starting position.





Data recall starting position



Data recall starting position setup mode



First digit flashing

- (c)    , and  are used for rd setting and entry.

Use the  and  keys to select the digit to be changed.

The digit that has been selected will flash.

Use the  and  keys to set the number and sign.

To set the sign, select the fifth digit, and use the  and  keys to set.



Fifth digit flashing

Sign display (Plus is not displayed.)

With the desired rd value set, press the ENTER key to enter.

Entering the rd value ends the setup mode, and returns the instrument to normal operations.



(4) Panel Setup Information Save (SS)

- (a) Insert an IC memory card in the instrument's IC memory card slot.

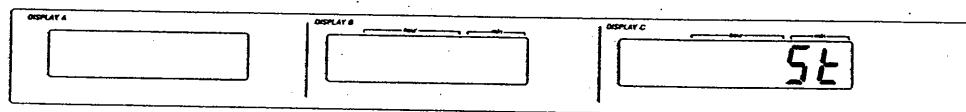
- (b)  Press the MENU key.



- (c)   ,  and are used for SS mode selection and entry.

Use the  and  keys to select **SS** (DISPLAY C display), and then press the ENTER key to enter the SS mode, and to save the current panel setup information to the memory card.

If there is already panel setup information saved to the memory card, that panel setup information is overwritten and updated.

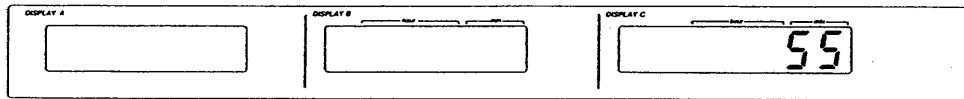

After saving to the memory card, the instrument returns to normal operation.



- If the MENU key is pressed before pressing the ENTER key in (c) above, the panel setup information is not saved to the memory card, and the instrument transfers to normal measurement mode.

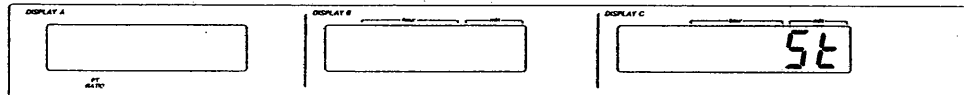

(5) Panel Setup Information Load (SL)

- (a) Insert an IC memory card in the instrument's IC memory card slot.

- (b)     Press the MENU key.



- (c)   , and  are used for SL mode selection and entry.

Use the  and  keys to select **5L** (DISPLAY C display), and then press the ENTER key to enter the SL mode; this loads the panel setup information previously saved on the memory card, and sets up the panel using this information.

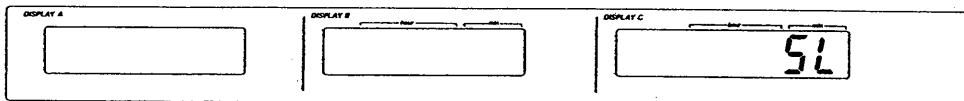

Loading the panel setup information from the memory card ends the panel setup, and transfer the 2532 to normal measurement mode.



- If the MENU key is pressed before pressing the ENTER key in (c) above, the panel setup information is not loaded from the memory card, and the instrument transfers to normal measurement mode.

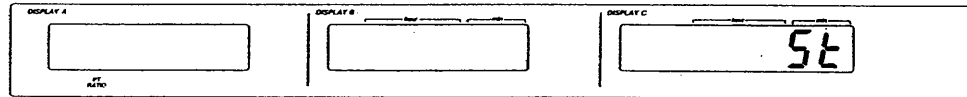

(6) Memory Card Initialization (CI)

(a) Insert an IC memory card in the instrument's IC memory card slot.

(b)  Press the MENU key.



(c)   , and  are used for CI mode selection and entry.

Use the  and  keys to select  (DISPLAY C display), and then press the ENTER key to enter the CI mode, and to initialize the memory card.

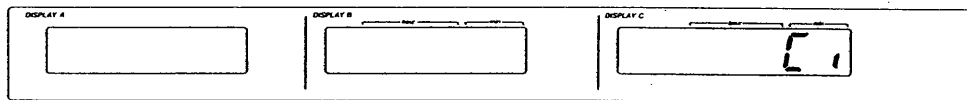





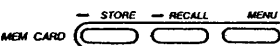

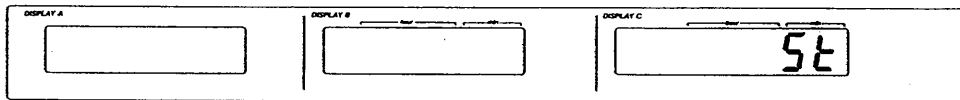
- When initialization is completed, the instrument returns to normal measurement mode.
- If the MENU key is pressed again before pressing the ENTER key in (c) above, the memory card is not initialized, and the instrument moves to normal measurement mode.

(7) Panel Setup Initialization (RC)

(a)  Press the MENU key.



(b)   , and  are used for RC mode selection and entry.

Use the  and  keys to select  (DISPLAY C display), and then press the ENTER key to enter the RC mode, and to initialize the panel setup.

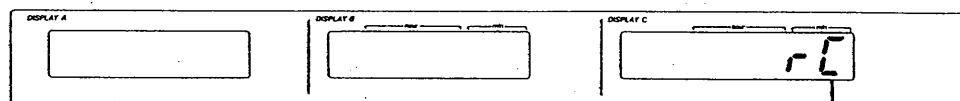

Flashing

- When initialization is completed, the instrument returns to normal measurement mode.
- If the MENU key is pressed again before pressing the ENTER key in (b) above, panel setup is not initialized, and the instrument transfers to normal measurement mode.

3.5.8 Interface Setup

(1) 253221 (GPIB)

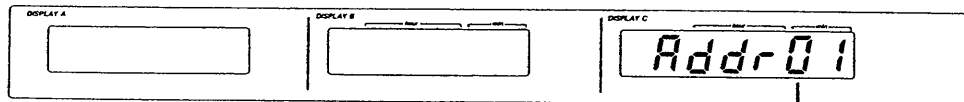

With the 2532 in local (LOCAL) mode (REMOTE LED to the left of DISPLAY A is turned off), the GPIB address can be set using the following operations.

- (a)  Press the INTERFACE LOCAL key.





Address first digit flashing
Address, 00 to 30

- (b)     , and  are used to set and enter the address.

Use the  and  keys to select the digit to be changed.

The digit that has been selected will flash.

Use the  and  keys to set a number for that digit.

- Address setting range is 00 to 30

With the desired address set, press the ENTER key to enter. If you attempt to enter a value outside of the setting range, error code 12 (*Err 12*) is displayed.

Entering the address ends the setup mode, and returns the instrument to normal operation.





This address is not subject to panel setup initialization; even if the panel is initialized, this value will be maintained.



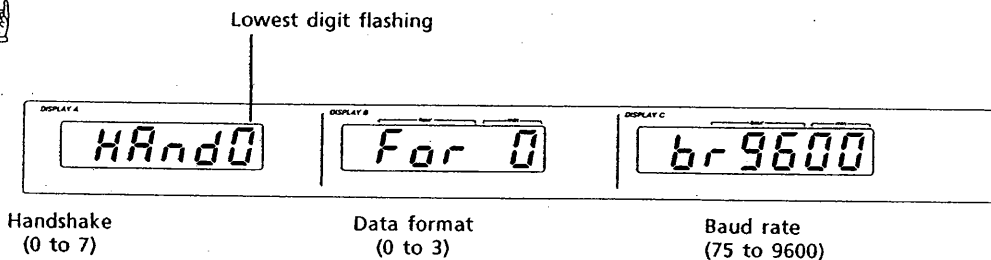

(2) 253222 (RS-232-C)

With the 2532 in local (LOCAL) mode (REMOTE LED to the left of DISPLAY A is turned off), the RS-232-C handshake, data format, and baud rate can be set using the following operations.





- (a)  Press the INTERFACE LOCAL key.



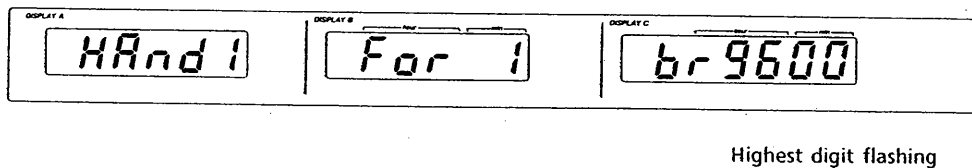

- (b)  ,  and are used to set and enter the handshake method. Use the  and  keys to set the desired handshake method, and press the ENTER key to enter. When entered, the lowest digit in DISPLAY B begins flashing.



- (c)  ,  and are used to set and enter the data format. As in (b) above, use the  and  keys to set the format, and then press the ENTER key to enter. When entered, the display changes as shown in the figure below.

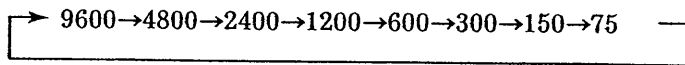

- (d)  , and  are used to select and enter the baud rate. Each time the  key is pressed, the set value changes as follows.



Pressing the  key cycles through the selections in the reverse order.

Use the  and  key to select the desired baud rate, and then press the ENTER key to enter the baud rate.

When the baud rate is entered, the instrument changes from the interface setup mode to normal operation.

This setup information is not subject to panel setup initialization; even if the panel is initialized, these values will be maintained.

- © See Item (2) and Item (4) in Section 6.2.2 concerning handshake methods and data format.

4. FUNCTION DESCRIPTION

4.1 Initialization

Initialization is the function that is used to set the set values and measurement parameters of the 2532 to their initial values, and to initialize the IC memory card.

(1) Measurement Item and Set Value Initialization

This sets the display, measurement range, measurement mode, scaling parameters, integration timer settings, and filter cutoff frequency settings to their initial values.

There are two ways to perform initialization :

- Using panel key operations (manual setup)
- Using GPIB or RS-232-C communications (remote setup)

See Table 4.1 for initial parameter values and statuses.

Table 4.1 Initial Parameter Values and Statuses

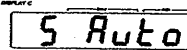
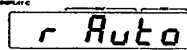
Item	Parameter or Mode	Initial Value	Display
Display	DISPLAY A DISPLAY B DISPLAY C	V (voltage) A (current) W (power)	V LED on A LED on W LED on
Measurement range	VOLTAGE RANGE CURRENT RANGE	600V 5A	600 LED on 5 LED on
Measurement mode	SCALING FILTER RMS/MEAN FREQ RANGE SAMPLE RATE INTEGRATOR	OFF OFF RMS LO 1.6s OFF	LED off LED off LED on LO LED on 1.6s LED on
Scaling value	PT RATIO CT RATIO EXT. SHUNT SCALING FACTOR	1.0000 1.0000 10.000A 1.0000	DISPLAY A DISPLAY B DISPLAY B DISPLAY C
Integration	Timer time	00000	DISPLAY C
Filter	fc (cutoff frequency)	2000Hz	DISPLAY C
Memory card	STORE RATE RECALL RATE NS (pretrigger count) RD (recall start data No.)	1.6s 0.1s 0001 0000	DISPLAY B DISPLAY B DISPLAY B DISPLAY B
	STORE MODE	Auto mode	DISPLAY C 
	RECALL MODE	Auto mode	DISPLAY C 

(2) IC Memory Card Initialization

This initializes the formatting and contents of the IC memory card. Always initialize an IC memory card before using it for the first time.

(3) Initialization Procedures

Table 4.2 shows the two setup procedures

Table 4.2 Setup Procedures

To Initialize: Procedure	2532 Itself	IC Memory Card
Manual setup	(Menu) Panel setup : r [MENU [,
Remote setup	Communication command : RC	Communication command : CI

(a) See subsections (6) and (7) in Section 3.5.6 concerning manual setup.

(b) Remote Setup

The communications commands for performing initialization via GPIB or RS-232-C are as follows. For details, see communications commands "RC" and "CI" in Section 6, "Communications Functions".

(i) Initialization of Panel Setup Such as Measurement Parameters

● Using GPIB

Syntax • RC <terminator>

● Using RS-232-C

Syntax • RC <terminator>

(ii) IC Memory Card Initialization

● Using GPIB

Syntax • CI <terminator>

● Using RS-232-C

Syntax • CI <terminator>

4.2 Computing Functions

The Model 2532 Power Meter is an intelligent power measuring instrument which measures the voltage, power, and active power of DC, single-phase AC, and mixed DC-AC circuits, and, based on these measurements, provides functions for computing reactive power, apparent power, power factor, phase angle, integration, frequency (optional), and other quantities from these measurements.

The primary computation functions of the 2532 are as follows:

- (1) Apparent power, reactive power, power factor, and phase angle computations
- (2) Scaling functions
- (3) Averaging functions
- (4) Integrator functions

The following describes these functions.

For information concerning the integrator function, see Section 4.5.

4.2.1 Apparent Power, Reactive Power, Power Factor, and Phase Angle Computations

(1) Apparent Power (VA)

- Computation formula : Apparent power (VA) = $V \times A$
- Computation range : See Table 4.3.
- Computation accuracy: $0.05\% \times$ apparent power at rated input
This does not include error in V and A measurements.

(2) Reactive Power (var)

- Computation formula : Reactive power (var) = $\sqrt{(V \times A)^2 - W^2}$
- Computation range : See Table 4.3. (For var ≥ 0)
- Computation accuracy: $0.05\% \times$ reactive power at rated input
This does not include error in V and A measurements.

Table 4.3 Computation Ranges for Apparent Power (VA) and Reactive Power (var)

		Current Input A							
		20.00mA	50.00mA	100.00mA	200.0mA	500.0mA	1.0000A	2.000A	5.000A
Voltage Input V	10.000V	200.0m	500.0m	1.0000	2.000	5.000	10.000	20.00	50.00
	15.00V	300.0m	750.0m	1.500	3.000	7.500	15.00	30.00	75.00
	30.00V	600.0m	1.500	3.000	6.000	15.00	30.00	60.00	150.0
	60.00V	1.200	3.000	6.000	12.00	30.00	60.00	120.0	300.0
	100.00V	2.000	5.000	10.000	20.00	50.00	100.00	200.0	500.0
	150.0V	3.000	7.500	15.00	30.00	75.00	150.0	300.0	750.0
	300.0V	6.000	15.00	30.00	60.00	150.0	300.0	600.0	1.500k
	600.0V	12.00	30.00	60.00	120.0	300.0	600.0	1.200k	3.000k

Values at rated input. Units are "VA" (apparent power), and "var" (reactive power).

(3) Power Factor (PF)

- Computation formula : Power factory (PF) = $\frac{W}{V \times A}$
- Computation range : -1.000 to 0.000 to 1.000
- Computation accuracy: ± 0.001

This does not include error in V and A measurement sections when power factor is one.

- Effective operating input range :
10% of range minimum for both voltage and current.
- Display if outside of effective operating range :
When input is outside of the effective operating range, and the computation result exceeds "1", display is as follows.

Table 4.4

Computation Result	Display
1.001 to 2.000	1.000
2.001 or more	PFErr

(4) Phase Angle (deg)

- Computation formula : Phase angle (deg) = $\cos^{-1} \left(\frac{W}{V \times A} \right)$
- Computation range : 0.0 to 180.0 deg
- Computation accuracy: ± 0.05 deg

This does not include error at phase angle parameter is 0 degrees, nor error in V and A measurements.

- Effective operating input range :
10% of range minimum for both voltage and current.
When computing phase angle (deg), make sure first that the voltage and current values are within the effective operating input range.
- Display if outside of effective operating range :
When input is outside of the effective operating range, and the power factor display exceeds "2.000", display is as follows.

degErr

4.2.2 Scaling Function

In the 2532, scaling factors can be set up for the voltage, current, and power measured values. Since external potential transformers (PT), current transformers (CT), and external shunts can be used to measure inputs beyond the measurement range, this function is useful in that it allows the measurements to be scaled so that they can be read in terms of primary-side values. Scaling of power (SCALING FACTOR) can be used to convert measurements to different physical units, for example, to calorie values.

If we take:

K_v (PT RATIO) as the voltage scaling factor,

K_i (CT RATIO) as the current scaling factor,

K_w (SCALING FACTOR) as the power scaling factor,

and K_s (EXT SHUNT) as the external shunt current factor,

then the display values for each function will be as follows when SCALING ON is selected.

	Measurement Data	Scaling Data
Voltage	V	$K_v \times V$
Current	A	$K_i \times A (\times K_s)$
Effective power	W	$K_v \times K_i \times K_w \times W (\times K_s)$
Reactive power	var	$K_v \times K_i \times K_w \times \text{var} (\times K_s)$
Apparent power	VA	$K_v \times K_i \times K_w \times VA (\times K_s)$

Where, ($\times K_s$) is the EXT SHUNT range.

(1) Scaling Factor Ranges and Initial Values

The following shows the ranges within which scaling factors can be set.

Table 4.5 Scaling Factor Ranges and Initial Values

Parameter	Range	Initial Value
PT RATIO	0.0001 to 10000	1.0000
CT RATIO	0.0001 to 10000	1.0000
SCALING FACTOR	0.0001 to 10000	1.0000
EXT SHUNT	0.0200 to 100.00A	10.000A

(2) When Using Shunts

When using a shunt, one of the 50mV, 100mV, or 200mV range group will be selected as the instrument input; if the current that makes the shunt output equal to the 100% of the selected input voltage range is then set up, the current can be read directly from the display.

The current display resolution under these circumstances is determined by the EXT SHUNT current value that has been set. Table 4.6 shows the display resolution.

Table 4.6 Display Resolution

EXT SHUNT Setting Current Value	Display Resolution
0.0200 to 0.1000A	0.01mA
0.1001 to 0.5000A	0.1mA
0.5001 to 1.0000A	0.0001A
1.0001 to 10.000A	0.001A
10.001 to 100.00A	0.01A

(3) Scaling Factor Setup Procedure

See Section 3.5.4 for details concerning factor setup procedures.

- If Scaling is ON, setting the scaling value starts the scaling computation. If the computation results exceed "99999 M", " - - o F - - " is displayed.
- If the instrument is used with the EXT SHUNT range, with SCALING OFF, the current value that is displayed is scaled using the external shunt current factor, Ks. Exercise care in this area, because if SCALING is then set to ON, the values will be further scaled by the current scaling factor Ki. Normally, Ki is set to 1.0000 when an EXT SHUNT range is used.
 - SCALING OFF : Current = Ks × A
 - SCALING ON : Current = Ks × Ki × A
- Note that even if the power scaling factor, KW, is some value other than 1.0000, and scaling is ON, the units are still displayed as "W", "VA", and "var". In such cases you must mentally convert to the desired units.

4.2.3 Averaging Function

If measurements are unstable and the display is difficult to read due to large fluctuations in the load or power source, or due to use of the Power Meter in low frequency measurement. In cases such as these the averaging function can be used to perform an exponential averaging computation on the measured values to stabilize the display and make it easier to read.

The formula for exponential averaging is as follows.

$$A_n = A_{n-1} + \frac{1}{K} (M_n - A_{n-1})$$

- A_n : Exponential averaging result data
 - A_{n-1} : Previous exponential average data
 - M_n : Measured data
 - K : Attenuation factor
- In the 2532, K=8.



When the AVG key is pressed and the LED turns on (AVG ON), the value displayed on the first cycle after that time is the measured value itself. On the second cycle this value is used as the previous exponential average data, A_{n-1}, to compute the averaged value.

4.3 IC Memory Card

- An IC memory card consists of a miniature memory board which integrates memory chips and other components into a single package, and contains a battery to back up the memory contents.
- The function of the IC memory card is to store and preserve measured data and panel setup information.
- IC memory cards having capacities from 8Kbytes to 64Kbytes can be used; such cards can hold from 200 to 2000 data points maximum in any mode except integration, or from 360 to 3800 data points maximum in integration mode.

Note 1 : Avoid inserting a memory card immediately after turning power on.

Note 2 : Do not touch the ground contact area, or let it become dirty.

If the LOW BAT LED (see ② in Figure 2.1) turns on when the IC memory card is inserted in the 2532, then the battery in the IC memory card is low. If this occurs, be careful; do not remove the card from the instrument. Removing the card will result in loss of all information on the card.

Note 3 : Refer to the figure below when replacing the battery in the memory card. The card must remain inserted in the instrument with the instrument power ON during replacement. If the battery is removed when IC memory card is not inserted in the instrument, all memory contents will be lost. Replace the battery with the IC memory card installed in the 2532 and power ON. The IC memory card battery has an expected life of approximately five years (8K, 16K bytes) and four years (64Kbytes).

(a) Battery Replacement Procedure 1 (Protects memory contents.)

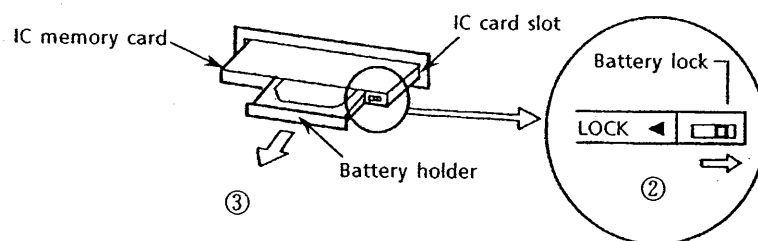

Figure 4.1 Battery Replacement Procedure 1

- ① With power ON to the 2532 main unit, insert the IC memory card into the slot provided for it.
- ② Release the battery lock.
- ③ Put your fingernail under the front center of the battery holder, and pull out slightly. So that the battery does not fall out, press on the bottom of the battery holder with your finger and pull out the battery holder.
- ④ Replace the battery in the battery holder.
- ⑤ Hold the battery in place by pressing with your finger, and insert the battery holder into the IC memory card.
- ⑥ Relock the battery holder.
- ⑦ Use the recall function to verify whether the information on the IC memory card has been preserved in the memory.
- ⑧ If the information on the IC memory card has been lost, initialize the IC memory card so that it can be reused.

- (b) Battery Replacement Procedure 2 (Memory contents lost)
After replacing the battery, initialize the IC memory card before using.

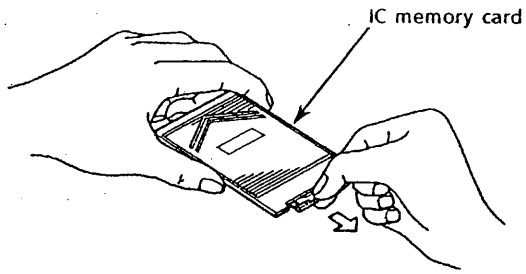

Figure 4.2 Procedure for Removing the Battery

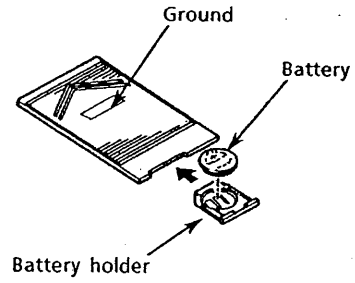

Figure 4.3 Procedure for Inserting the Battery

4.4 Store Function and Recall Function

4.4.1 Overview

(1) Functions and Operating Mode

The functions associated with the IC memory card of the 2532 are as follows.

- Store function : Stores data measured by the 2532 to the IC memory card.
- Recall function : Retrieves to the 2532 the measured data previously stored on the IC memory card.

The following operating modes apply to each of these functions.

- Auto (AUTO) mode : Overwrite function
Pretrigger function
- N reading (N READING) mode
- Single (SINGLE) mode (when display update hold is on)

Using the STORE key and the RECALL key, the following operations can be performed, depending on the mode set up in the 2532.

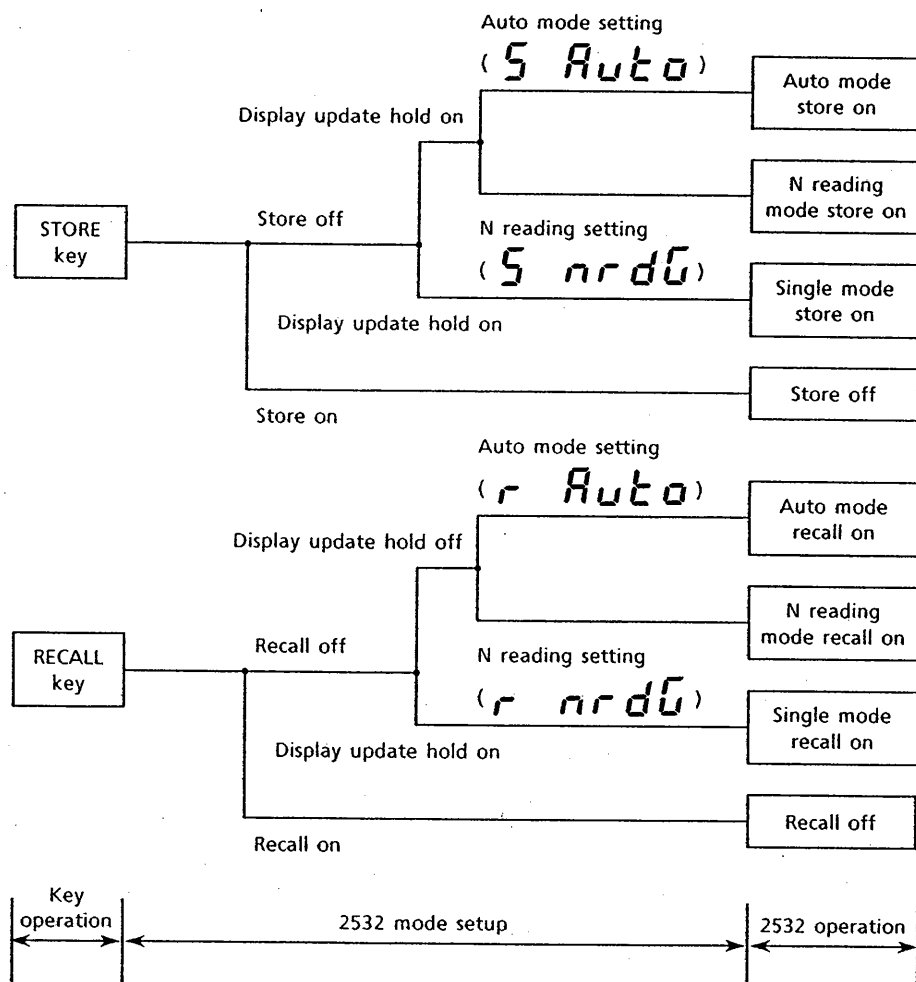

(2) Function and Operating Mode Setup

The functions and operating modes described in (1) above can be selected using the MEM CARD MENU key ().

Functions and operating modes that are included in the MENU are classified as shown in Figure 4.4.

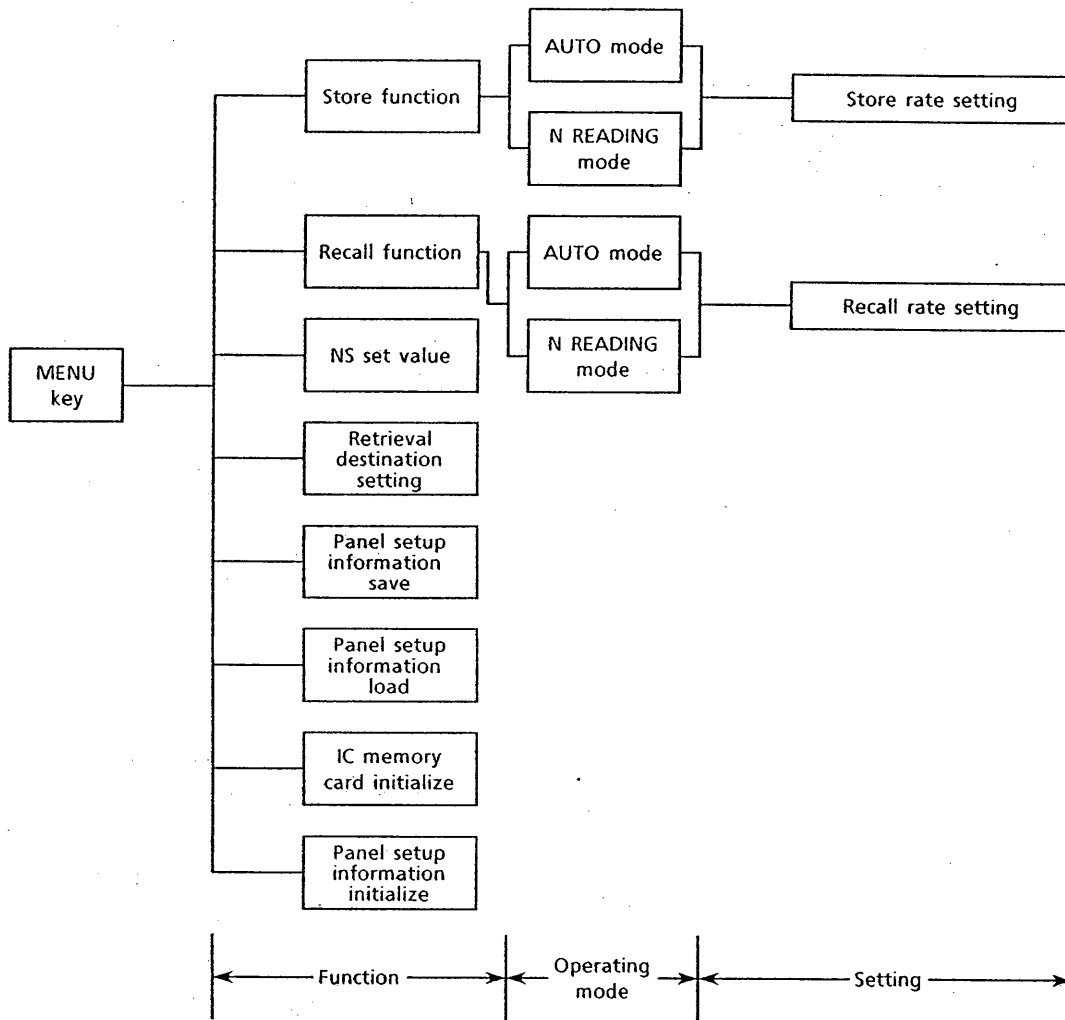

Figure 4.4

Each of these functions is described below. See Section 3.5.7 for a details concerning function selection, and operating mode and numeric value setup.

4.4.2 Store Function

(1) Overview

The store function stores measured data to a data file on the IC memory card. The file name is "M2532-N.DAT", for functions other than integration; the file name is "M2532-I.DAT" for integration. The maximum number of data samples that can be stored differs according to the memory capacity of the IC memory card, and according to whether or not it is from integration or from another function.

Table 4.7 IC Memory Card Capacities, and Maximum Number of Data Samples Stored

IC Memory Card Capacity \ Maximum Number of Data Samples Stored	Function other than Integration (M2532-N.DAT)	Integration (M2532-I.DAT)
8Kbytes	200 data samples	360 data samples
16Kbytes	500 data samples	900 data samples
32Kbytes	1000 data samples	1700 data samples
64Kbytes	2000 data samples	3800 data samples

- The data stored when averaging is ON is the averaged data.
- The data stored when scaling is ON is the unscaled data (not the scaled data).
- Changes cannot be made to the following settings while store is ON; an error code will be displayed (**Err 13**).
 - (i) Display update hold
 - (ii) Display update interval
 - (iii) Store and recall parameters (store rate, store operations, NS value, recall rate, recall operations, store data recall starting position)
 - (iv) Setup information save
 - (v) Setup information load
 - (vi) IC memory card initialization
 - (vii) Panel setup information initialization
 - (viii) Function change from integration mode to a mode other than integration mode, or from a mode other than integration mode to integration mode
- When store is set to ON, previously existing data files are deleted (previously stored data is deleted).
- If store is set to on while recall is ON, recall automatically goes off, and store operation begins.
- If the memory card is removed while store is ON, store automatically goes to OFF. If the memory card is removed while data is being written to a data file, the data stored up to that point cannot be recalled.

(2) Store Operation

The following modes apply to store operations.

- (a) Auto (AUTO) mode
- (b) Single (SINGLE) mode
- (c) N reading (N READING) mode

(a) Auto (AUTO) Mode

- Performing the store operation setup as auto mode (*S Auto*) with display update (SAMPLE) hold set to OFF (HOLD LED is OFF) results in operation in auto mode.
- When store is set to ON, measured data is immediately stored in sequence beginning at the start of the file at the previously specified store rate. Pressing the store key a second time turns store off.
When data has been stored up to the capacity of the file, operations return to the start of the file and overwrite the existing data file contents. Be careful, since data is automatically erased in sequence, beginning from the oldest data.
- The pretrigger function is enabled in this mode. The pretrigger function acts such that, when the trigger is generated, the instrument preserves the immediately previous NS-1 data samples (where NS is the "pretrigger sample count"), and continues storing additional data. However, if the trigger is generated when the time elapsed since the store mode was turned on has not been sufficient to store NS-1 data samples, then however much data was previously stored retained, and data storage continues from that point. When the amount of data stored reached the capacity of the file, store mode is automatically turned off.

(b) Single (SINGLE) Mode

- When display update (SAMPLE) hold is ON (HOLD LED is ON), the store function operates in single mode.
- When store is set to ON, measured data samples are stored in sequence one at a time, each time a trigger is generated, beginning from the start of the file.
- When the number of data samples stored reaches the previously specified NS (pretrigger count) value, store mode is automatically turned off.
- If the NS value is greater than the maximum number of data samples that can be stored, data is stored up to the capacity of the file, and store mode is automatically turned off.

(c) N Reading (N READING) Mode

- Store is in N reading mode when the store operation setting is set to N reading mode (*S nrdr*), and display update (SAMPLE) hold is set to off (HOLD LED is OFF).
- When store is set to ON, measurement stops, and the instrument goes to the trigger standby status. If a trigger is generated while in this status, measurement starts, and NS data samples are stored in sequence from the start of the file at the previously specified store rate.
- After NS data samples have been stored, measurement stops, and the store function goes to a temporary halt status (trigger standby status) until the next trigger is generated**. If another trigger is generated while the 2532 is in this status, NS data samples are again stored.
- Operation continues in this way; each time a trigger is generated**, NS data samples are stored, until the amount of data stored reaches the capacity of the file, at which time store is automatically turned off.

- If the NS value is greater than the maximum number of data samples that can be stored in the file, data is stored up to the capacity of the file without stopping, and the store function automatically turns off.
- * See Item (4) in Section 4.4.2 concerning NS.
- ** A trigger can be generated by pressing the SAMPLE TRIG key; by a contact input from the remote control connector on the rear panel, or by transmission of a <GET> (for GP-IB only), "E" or "ST" command from the communications interface.

(3) Store Rate

In auto mode or N reading mode, store operations store data periodically at a previously specified store rate. The store rate setting differs both according to whether the function is integration mode or a mode other than integration mode, and, for modes other than integration mode, according to whether the display update interval is 0.4 seconds or 1.6 seconds. Table 4.8 shows the store rates that can be selected.

Table 4.8 Display Update Interval and Store Rate

	Other than Integration Mode		Integration Mode
	Display Update Interval 0.4 sec	Display Update Interval 1.6 sec	
Store Rate	0.4 s		1 s
	1.2 s	1.6 s	4 s
	4 s	4.8 s	10 s
	10 s	9.6 s	30 s
	30 s	30.4 s	60 s
	60 s	60.8 s	300 s
	300 s	272 s	600 s
	600 s	600 s	1800 s
	1800 s	1800 s	3600 s
	3600 s	3600 s	

(4) NS Value

The meaning of the NS value during a store operation depends on the store operation mode, as shown below.

- Auto mode : Pretrigger count
- Single mode : Preset count
- N reading mode : Number of data samples stored for each trigger

If the specified NS value is greater than the maximum number of data samples that can be stored in the file, the maximum number of data samples that can be stored is used as the NS value.

4.4.3 Recall Function

(1) Overview

- The recall function retrieves measured data saved in data files on an IC memory card. Data that is in a data file of the name (M2532-N.DAT), used for non-integration data (data taken in any mode other than integration), cannot be recalled if the instrument is in integration mode. Likewise, data that is in an integration data file (M2532-I.DAT) cannot be recalled if the instrument is in any other mode than the integration mode. If such an operation is performed, error code 32 (*Err 32*) is displayed.
- Performing a recall when averaging is ON does not cause averaging to be performed on the data that is recalled.
- If data is recalled when scaling is ON, scaling is performed on the data that is retrieved.
- Changes cannot be made to the following setup parameters and modes while recall is ON; an error code will be displayed (*Err 13*).
 - (i) Display update hold
 - (ii) Display update interval
 - (iii) Store and recall parameters (store rate, store operation, NS value, recall rate, recall operation, stored data recall start position)
 - (iv) Setup information save
 - (v) Setup information load
 - (vi) IC memory card initialization
 - (vii) Panel setup information initialization
 - (viii) Measurement parameters (mode)
 - Auto range on/off
 - Voltage/current range
 - RMS/MEAN
 - Frequency range
 - Filter on/off
 - Filter value
 - Shunt current value
 - (ix) DISPLAY C function change
- If recall is set to on while store is on, store is automatically turned off, and recall operation begins.
- If the memory card is removed while recall is on, recall is automatically set to OFF.

(2) Recall Operation

The following modes apply to recall operations.

- (a) Auto (AUTO) mode
- (b) Single (SINGLE) mode
- (c) N reading (N READING) mode

(a) Auto (AUTO) Mode

- Recall is in auto mode when the recall operation setting is set to auto mode (*r Auto*), and display update (SAMPLE) hold is set to OFF (HOLD LED is OFF).
- When recall is set to ON (RECALL LED is ON), store data retrieval begins immediately at the previously specified recall rate, beginning from the specified memory data recall start position.
- After the last data is retrieved, recall is automatically turned OFF.

(b) Single (SINGLE) Mode

- Single mode is the recall mode that results if recall is turned on when display update (SAMPLE) hold is ON (HOLD LED is ON).
- When recall is set to ON in single mode, data samples are retrieved one at a time, starting from the specified recall start position; one data sample is retrieved each time a trigger is generated.
- After the last data sample is retrieved, recall is automatically turned off.

(c) N Reading (N READING) Mode

- Recall operates in N reading mode when the recall operation setting is set to N reading mode (*r nrdu*), and display update (SAMPLE) hold is set to OFF (HOLD LED is OFF).
- When recall is set to ON in this mode, measurement stops; if a trigger is generated while the 2532 is in this status, NS data samples are recalled beginning from the specified recall start position.
- After NS data samples have been recalled, recall goes to a temporary halt status until the next trigger is generated, at which time the next NS data samples are retrieved.
- Operation continues in this way; each time a trigger is generated, NS data samples are retrieved, until the last data sample in the file is retrieved, at which time recall is automatically turned off.
- See Item (4) in Section 4.4.3 concerning NS.

(3) Recall Rate

In auto mode or N reading mode, recall operations retrieve data periodically at a previously specified recall rate. The recall rate setting can be selected from the following recall rates.

0.1s, 0.2s, 0.4s, 1.2s, 4s

- © Since data may be lost if 0.1s is selected when RS-232-C is being used for communications, set at 0.2s or more this case.

(4) NS Value

For N reading mode, the NS value when recall is ON represents the number of data samples retrieved for each trigger.

(5) Data Recall Start Position

For recall, the data recall start position must be set before beginning the recall. The valid range of data sample numbers for the data recall start position within a stored data file differs according to the type of data file.

Table 4.9 IC Memory Card Capacity and Data Recall Start Position

IC Memory Card Capacity \ Data File	Other than Integration (M2532-N.DAT)	Integration (M2532-I.DAT)
8Kbytes	-199 to 199	-359 to 359
16Kbytes	-499 to 499	-899 to 899
32Kbytes	-999 to 999	-1699 to 1699
64Kbytes	-1999 to 1999	-3799 to 3799

The valid range of data sample number for the recall start position within the stored data file is determined as followed by the operating mode when store is performed.

(a) For Auto Mode

- ① Treating the first data sample stored when store is set to ON as No. 0, the valid range of data sample numbers for stored data recall start position is 0 to (S-1).

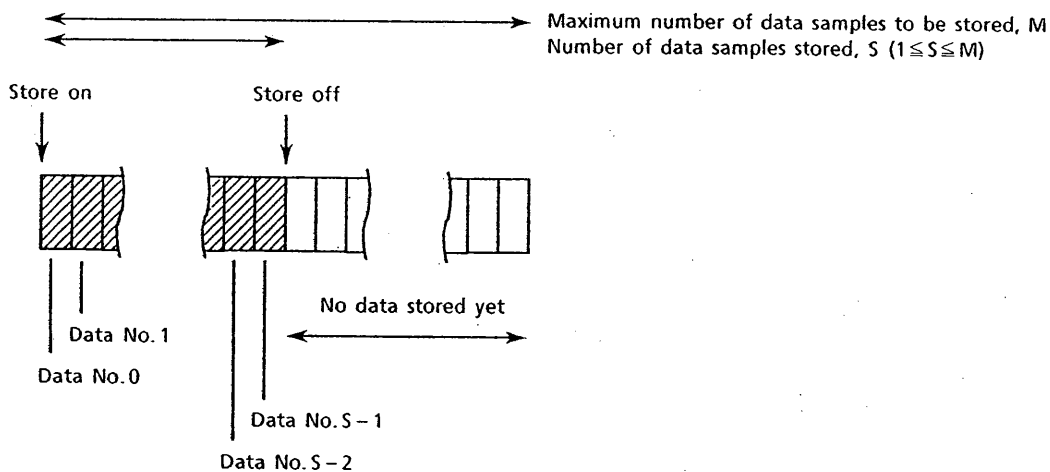

- ② If overwriting, the oldest stored data sample is data No. 0, and the valid range of data No. for stored data recall start position is 0 to (M-1).

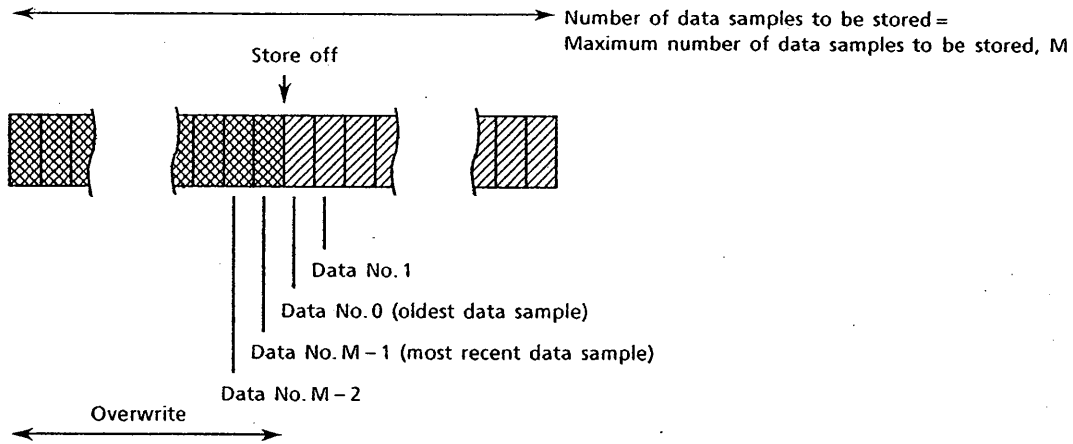

- ③ If the pretrigger function is used, the data sample stored at the time the trigger is generated is data No. 0, and the valid range of data No. for memory data recall starting position is $-(NS-1)$ to $(M-NS)$.

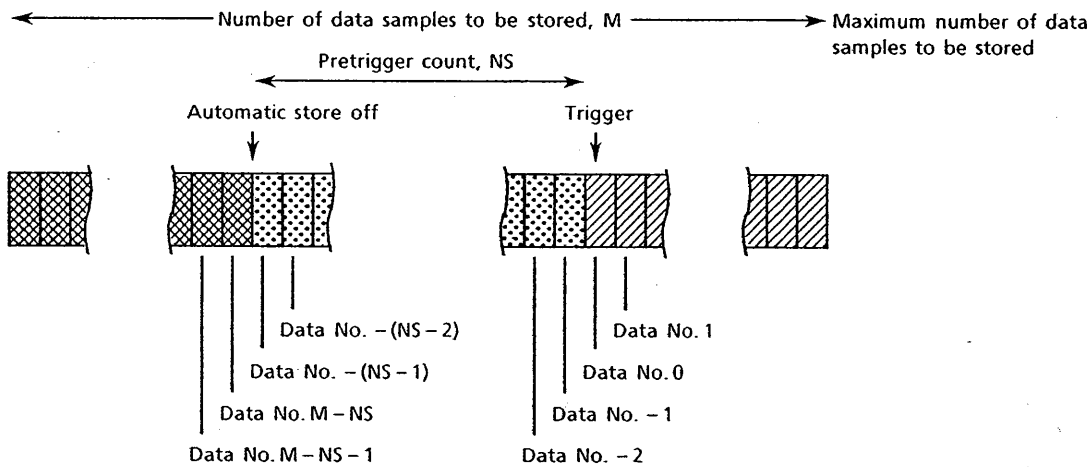

- ④ If the trigger was generated when the number of data samples stored since store was turned on had not yet reached $NS-1$, the valid range is $-S$ to $(M-S-1)$.

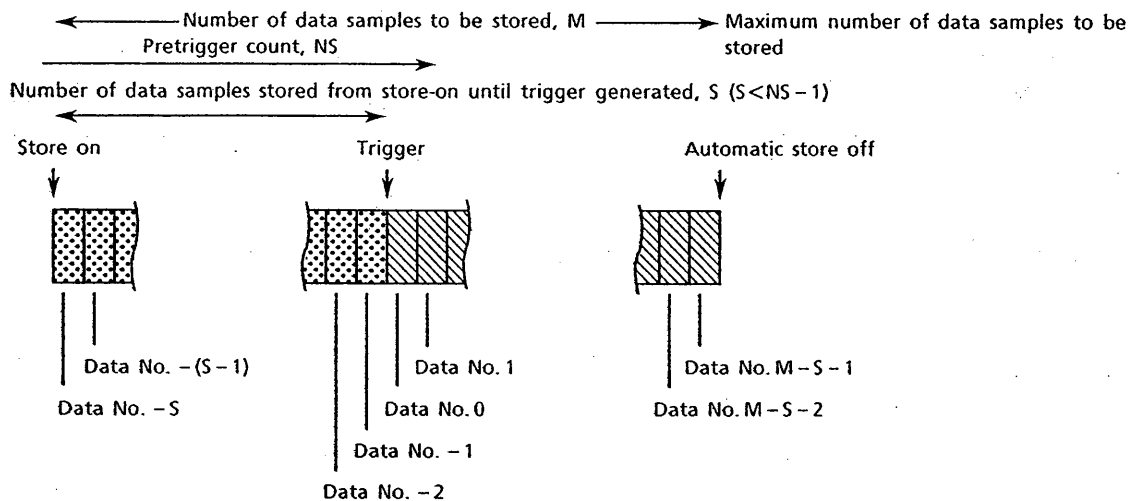

- ⑤ If store was turned off after the trigger was generated but before reaching the number of data samples at which it would have automatically turned off, the valid range is $-(M-T)$ to $(T-1)$, or $-S$ to $(T-1)$.

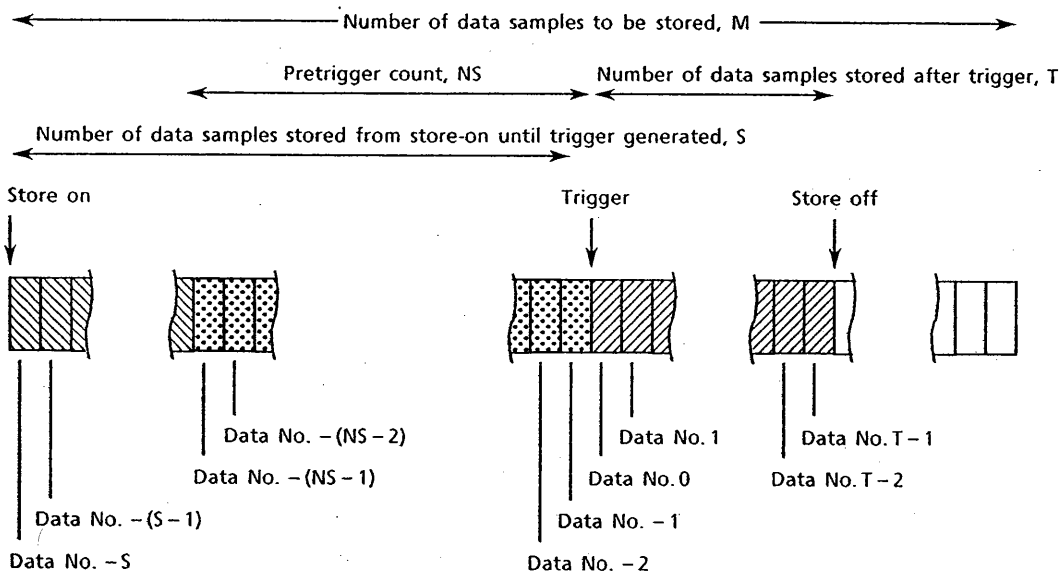
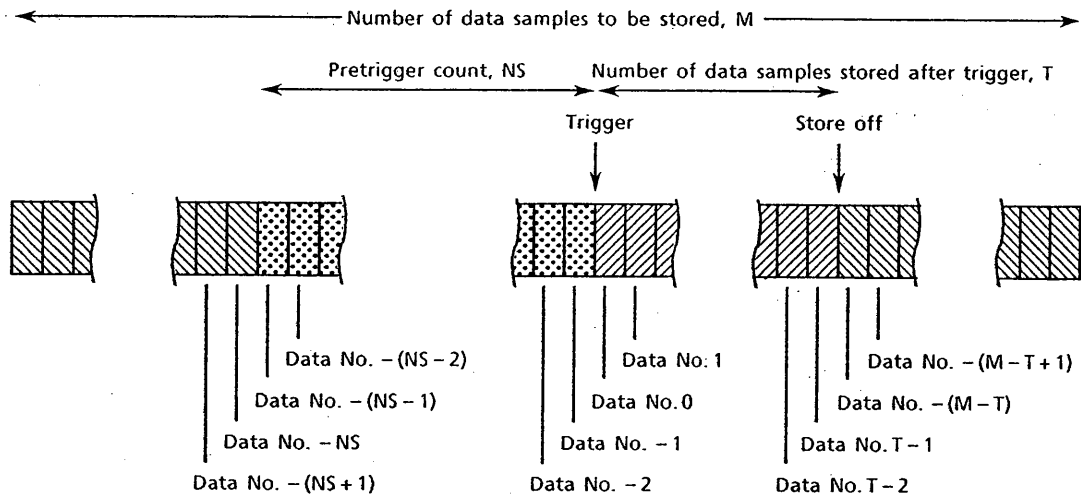

(b) For Single or N Reading

The first data samples stored after store is turned on is data No. 0, and the valid range of data No. for memory data recall starting position is 0 to $(S-1)$. See ① under (a) above.

4.5 Integrator Function

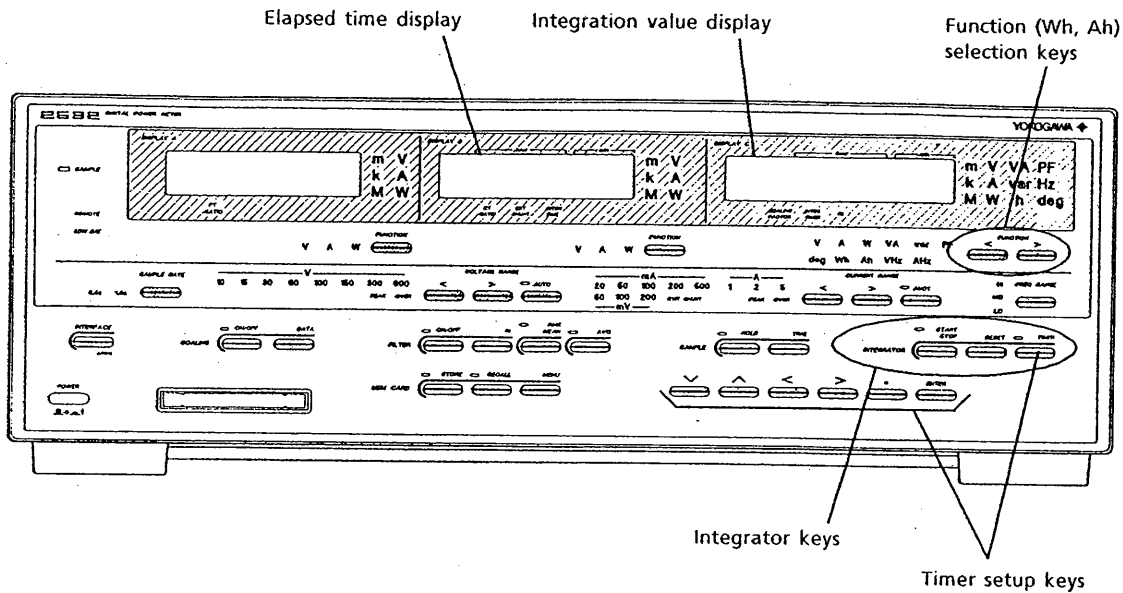

Figure 4.5 Integration Display and Setup Keys

The integrator function is the function that is used to perform active power integration (Wh) or current integration (Ah). When the integrator function is in use, the integration value is displayed on DISPLAY C, and the elapsed time is displayed on DISPLAY B, as shown in Figure 4.5.

The integration value is generally changes in the increasing direction, but if measurement is negative, the integration value will decrease, and may go to a negative value.

The following two modes apply to the integration function.

- (1) Manual integration mode
- (2) Standard integration mode

NOTE

- ◎ The display update interval for integration operations is 1 second. Therefore the display update interval (SAMPLE RATE) 0.4s and 1.6s indicators turn off. The integration operation is performed for 980ms of the 1 second; in the remaining 20ms, the average value over the preceding 980ms is compensated by computation to yield an integration value for 1 second.
- ◎ The frequency range (FREQ RANGE) for the integration operation is fixed at the LO range (20Hz to 16kHz DC). Even if another range has been specified, when the integration operation starts, the range changes automatically to the LO range.

4.5.1 Manual Integration Mode (Timer Time Set to 00000)

As shown in Figure 4.6, in manual integration mode, pressing the  key turns on the LED, and starts the integration operation, and integration continues until the key is pressed a second time. If the display data exceeds 999999 (ignoring the decimal point) integration stops automatically, and the integration value and integration time values are held on the display.

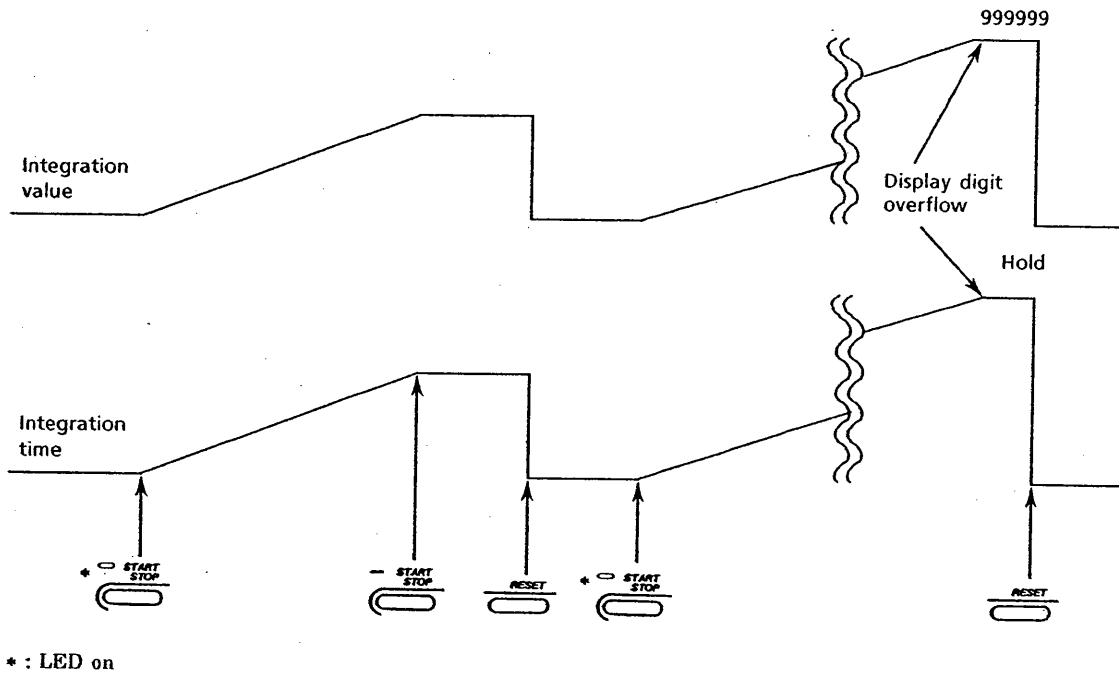

Figure 4.6 Manual Integration Mode

(1) Manual Integration Mode Selection

If the timer is set to **00000**, integration operates in manual integration mode.

See Section 3.5.6 concerning the timer setup procedure.

The initial mode is manual integration mode.

(2) Display Resolution

The display resolution multiplier is 20000 during integration. For example, if the voltage range is 100V, and the current range is 2A, the power integration range is 200.00Wh, and active power is integrated using a resolution of 0.01Wh.

Under these conditions, the time at which the integration result exceeds 999999 is $9999.99 / 200.00$, about 50 hours, and the integration value at that time will be 9999.99Wh.

The timer stops at an elapsed time of 999h. Units are displayed as ... mWh, ... Wh, ... kWh, or ... MWh, according to the decimal point position.

4.5.2 Standard Integration Mode

The standard integration mode is selected by entering any timer setting other than 00000.

In standard integration mode, display resolution is selected automatically according to the timer setting. As shown in Figure 4.7, when the timer times out (elapsed time reaches the time setting), integration ends automatically and the integration value and integration time display values are held.

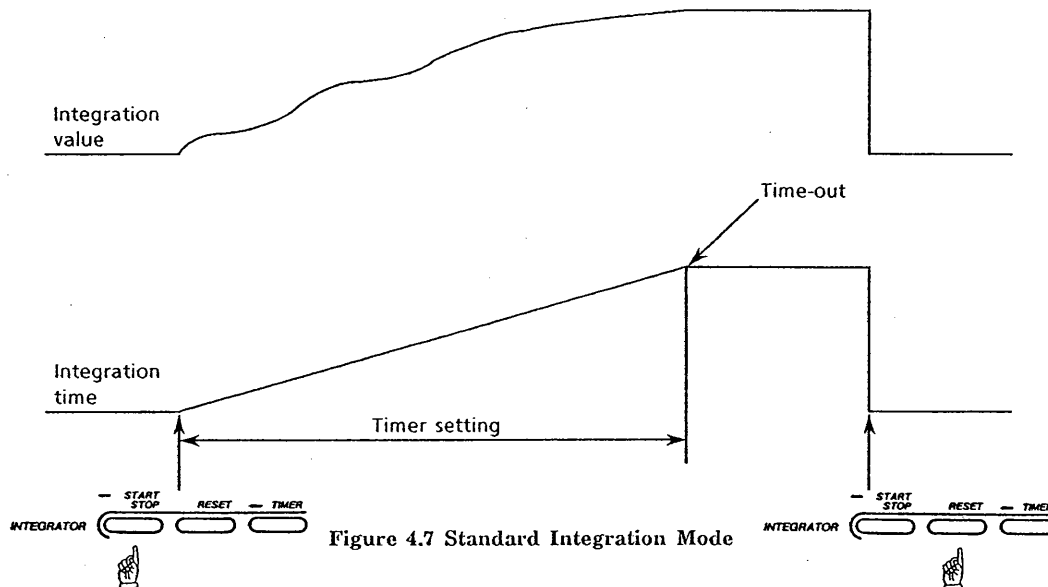

Figure 4.7 Standard Integration Mode

Table 4.11 shows how display resolution is determined according to the timer setting. For example, if the timer is set to 24 hours, display resolution becomes "Times 0.1". Therefore, since the integrated power for 1 hour is 200Wh if the voltage range is 100V and the current range is 2A, integration is performed using a resolution of 0.1Wh, because $20000 \times 0.1 = 2000$, which corresponds to 200.0Wh.

Table 4.11 Timer Setting and Display Resolution

Timer Setting (hour : min)	Resolution Relative to Rated W/A Display	
00:01 to 01:00	Times 10	Decimal point position and multiplication factor are determined such that integration of rated display value for 1 hour does not exceed 200000 (ignoring decimal point).
01:01 to 10:00	Times 1	Decimal point position and multiplication factor are determined such that integration of rated display value for 1 hour does not exceed 20000 (ignoring decimal point).
10:01 to 100:00	Times 0.1	Decimal point position and multiplication factor are determined such that integration of rated display value for 1 hour does not exceed 2000 (ignoring decimal point).

Manual STOP and START is permitted while integration is in progress. If manual stop is used, the time during which integration is stopped is not counted; only the time during which integration is actually performed is displayed.

4.5.3 Backup During Power Failure

If a power failure occurs while integration is in progress, the integration value and integration time are preserved by a backup function. When power is restored, integration remains stopped. Although the data is retained, integration cannot be restarted after the power failure. To perform another integration, press the reset key, and then press the start key. Note, however, that this resets the data from the previous integration.

4.5.4 Integration Operation Start, Stop, and Reset

Integration operation start, stop, and reset can be performed by any of the following three methods.

- By operating the integrator keys (see Section 4.5.6) on the front panel of the 2532.
- Using GPIB/RS-232-C commands (see Section 6.3, "Communication Commands").
- By means of a contact input from the remote control connector (see Section 4.5.7, "Using Connectors")

Start, stop, and reset can be performed any of these integration modes.

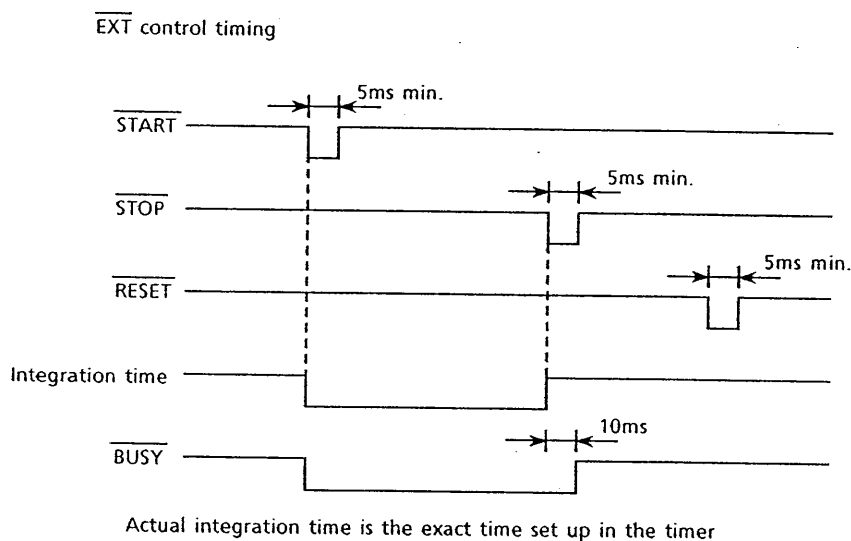
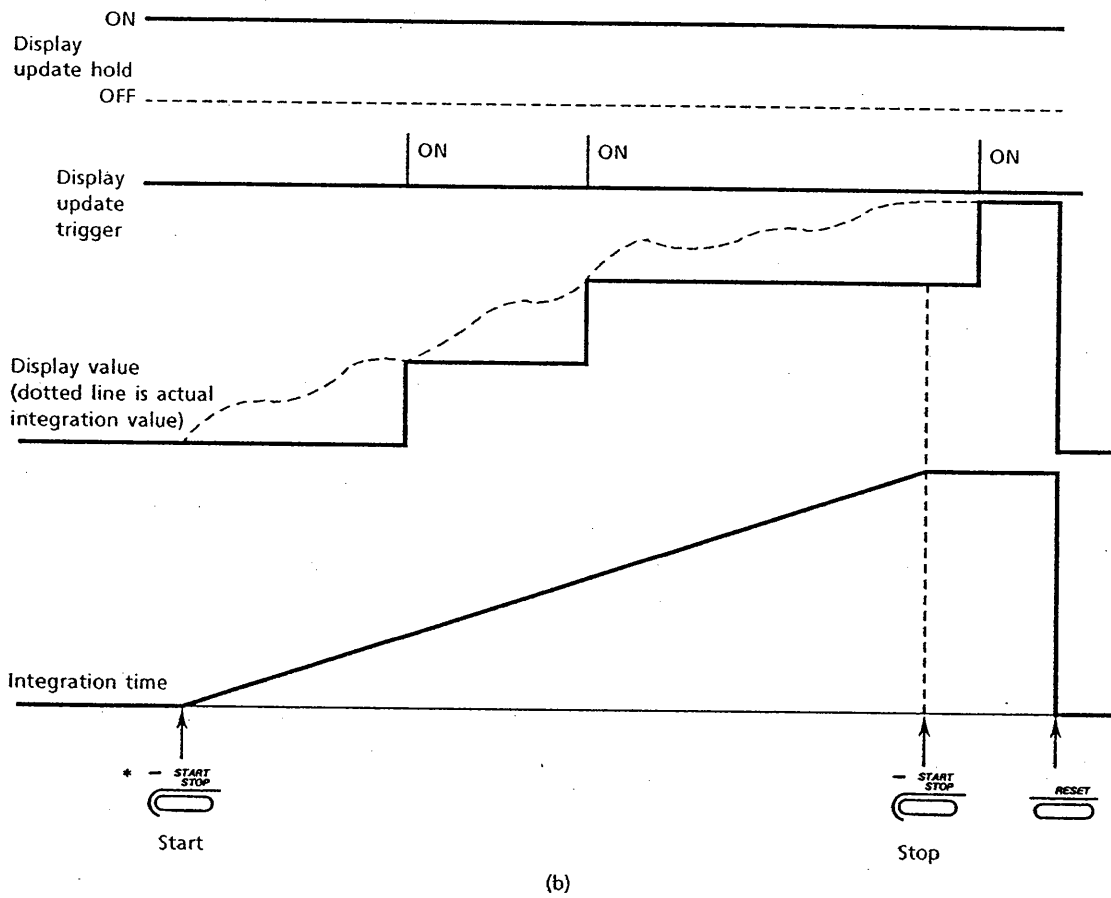
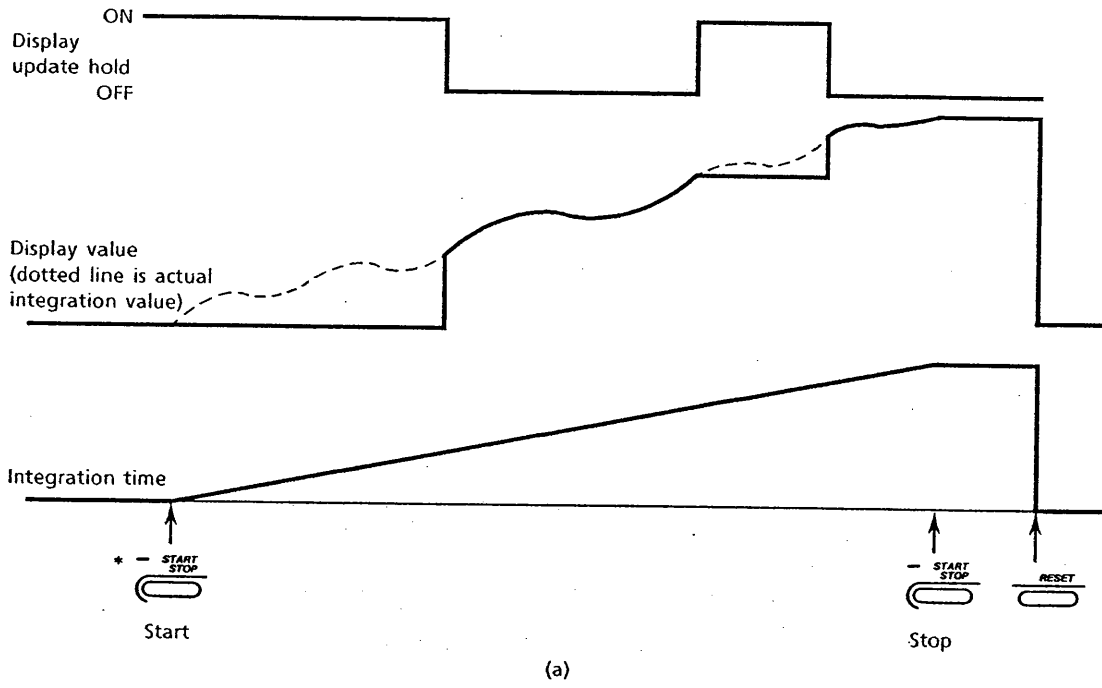

Figure 4.8 EXT Control Timing

4.5.5 Integrator Function Operation When Display Update (SAMPLE) Hold is ON

When display update (SAMPLE) hold is ON, the display and GPIB output are put on hold; integration, however, continues to be executed regardless of whether display update (SAMPLE) hold is ON or OFF.

- If integration is started with display update (SAMPLE) hold ON, as shown in (a) and (b) in Figure 4.9, the integration display value remains ON hold. However, turning display update (SAMPLE) hold OFF or pressing the display update (SAMPLE) trigger (TRIG) key will result in immediate display of the integration value accumulated up to that time.
- If integration is stopped while display update (SAMPLE) hold is ON, as shown in (b) in Figure 4.9, then the 2532 continues to hold the integration value as-is. The final integration value can be displayed by pressing the display update (SAMPLE) trigger (TRIG) key, or by turning display update (SAMPLE) hold OFF.
- If power fails while display update (SAMPLE) hold is ON, the values displayed when power is restored are the actual integration value and integration time as of the time at which power failed (not the values that were being held). However, if the timer has timed out prior to the power failure, the integration value at time-out will be displayed.





* : LED ON

Figure 4.9 Integration Operation with Sample Hold ON

4.5.6 Integrator Key Operations

When the Wh or Ah integration function is in use, the integration function may be in either of two sets of states — NOT RESERVE or RESERVE — according to the state of the internal integrator.

The NOT RESERVE states are those in which the integration function is not operating. As shown in the figure, in these states the integrator key  key lamp is OFF.

The RESERVE states are those in which the integration function is operating. In these states the integrator key  key lamp is ON, and integration values may be displayed in DISPLAY C.

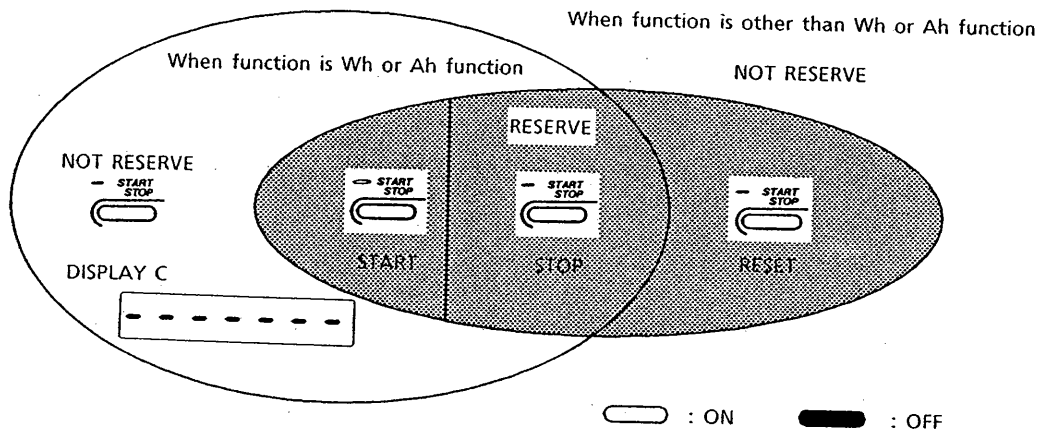

Figure 4.10 Integrator Key Operations

Certain keys on the front panel are protected during integration operations so that their setup information cannot accidentally be changed by touching the keys on the front panel of the 2532. Table 4.12 shows these keys.

For example, when the instrument is in the RESERVE START state during a Wh integration operation, the display will not be changed by touching the keys marked with an "X" in the table.

Table 4.12

Key \ State		For Wh or Ah Functions			For Functions other than Wh or Ah Functions	
		NOT RESERVE	RESERVE		RESERVE	NOT RESERVE
			START	STOP	STOP	
MODE	RMS/MEAN FILTER	○	×	×	×	○
	AVG SCALING	○	○	○	○	○
SAMPLE	SAMPLE RATE	×	×	×	○	○
	HOLD TRIG	○	○	○	○	○
RANGE	VOLTAGE AUTO	×	×	×	×	○
	<, >	○	×	×	×	○
	CURRENT AUTO	×	×	×	×	○
	<, >	○	×	×	×	○
	FREQ	○	×	×	×	○
Data setup	SCALING DATA FILTER fc TIMER V, Λ, <, >, ENTER	○	×	×	×	○
MEM CARD	STORE MENU	○	○	○	○	○
	RECALL	○	×	×	○	○
DISPLAY A, DISPLAY B functions		Not displayed			○	○
DISPLAY C functions		○	Only Wh or Ah permitted	○	○	○
INTEGRATOR	START/STOP	○	○	○	×	×
	RESET	×	×	○	×	○

Keys marked with a ○ in the table can be changed

Integration Operation Examples

Figure 4.11 illustrates how integration operations will be affected by the pressing of other function keys.

- Note that integration cannot be started if the PEAK OVER lamp is ON for the voltage range or current range.
- Note also that when integration is in progress, any instantaneous value exceeding three times the voltage or current range rated value will be integrated as having a value of three times the rated value of the range. If the effective value exceeds 2 times the rated value (for Wh) or 1.4 times the rated value (for Ah), the value is integrated as 2 times or 1.4 times the rated value, respectively.

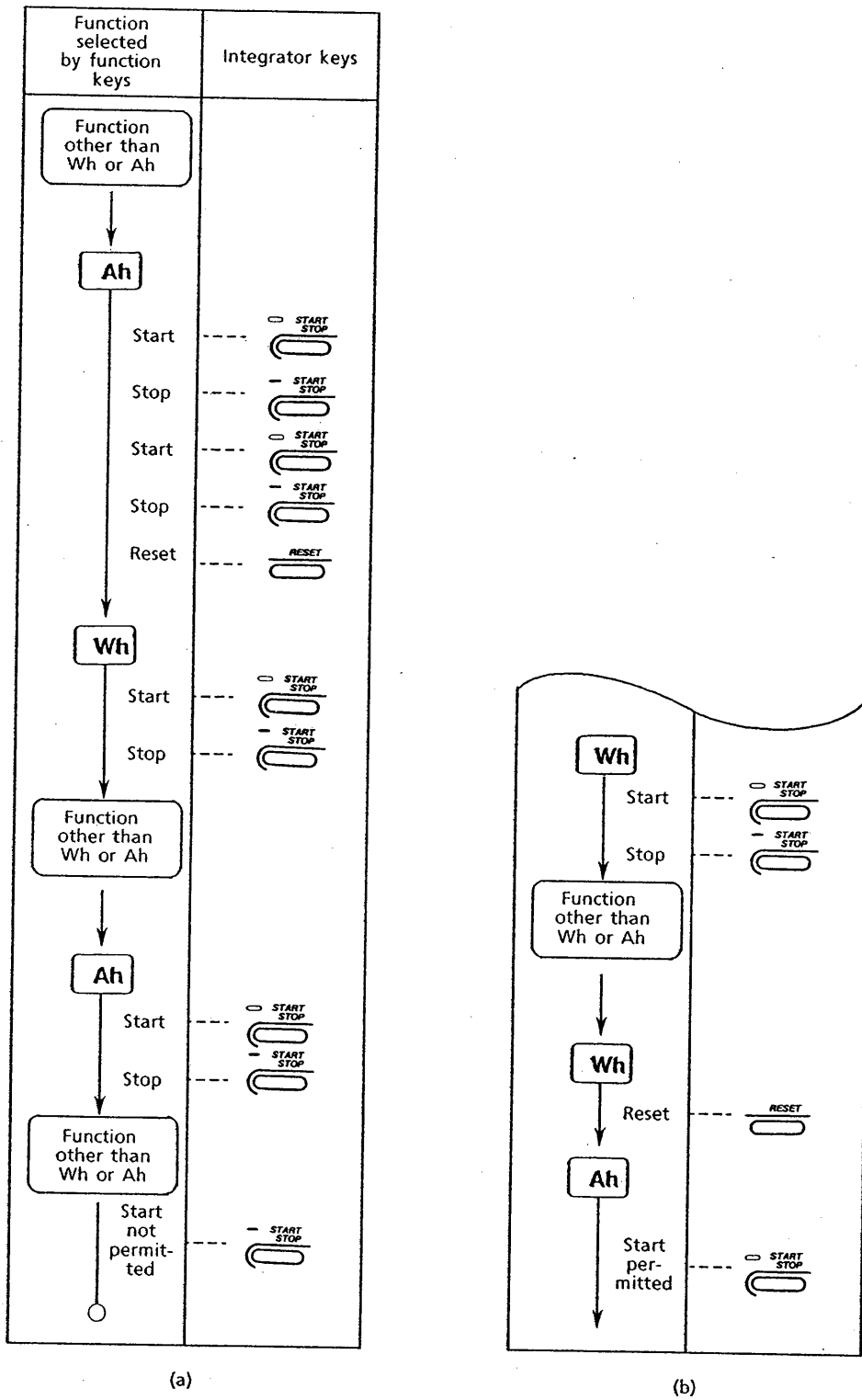











Figure 4.11 Integration Operation Examples

Notes on Integration (Wh or Ah) Mode

- ① If the DISPLAY C display shows “ - - - - - ” when the DISPLAY C function is Wh or Ah, this indicates that the instrument is in integration start standby status. In this status, all key operations are enabled.
- ② If the an integration value is visible in DISPLAY C display when the DISPLAY C function is Wh or Ah, this indicates that the integration function is operating, and no key operations can be performed using protected keys such as the range key.
If such key operations are attempted, error code 13 (*Err 13*) is displayed in DISPLAY C.
- ③ The reset key is disabled while integration is in progress.
If a reset key operation is attempted, error code 45 (*Err 45*) is displayed in DISPLAY C.
To reset, first press the START/STOP key to stop integration, and then press the reset key.
- ④ For setting to any function other than Wh or Ah, press the START/STOP key to stop integration, and then press the reset key.
DISPLAY C shows “ - - - - - ” and this condition enables change to any other function.

<Error Code Display Examples>

Front Panel Key Operations	Integrator Keys	DISPLAY C	Remarks
Function other than Wh or Ah			
Wh		-----	Integration start standby
Start		Wh integration value	
Ah	Lamp on	Ah integration value	Can switch between Wh and Ah while integration is in progress.
Stop		↓	
Start		Err 13	Cannot switch to other functions while integration is in progress.
Function other than Wh or Ah			
Wh		Wh integration value	
Stop		↓	
Key protected by integration mode, such as a range key		Err 13	Because still in integration mode, certain keys are protected until the reset key is pressed.
Reset		Wh integration value	
Function other than Wh or Ah		-----	Depends on function
Wh		Err 42	Integration cannot be started if function is other than integration.
Start		-----	
Reset		Wh integration value	Reset not permitted while integration in progress.
Wh		Err 45	
Stop		Wh integration value	
Reset		↓	
Function other than Wh or Ah		-----	

4.5.7 Using the Remote Control/Analog Output Connector

The remote control/analog output connector can be used for the following purposes.

- (1) To start, stop, and reset the integration function via an external signal;
- (2) To control display update (SAMPLE) hold, and display update (SAMPLE) trigger, via an external signal;
- (3) To output the 100Hz clock signal used as the timer time base;
- (4) To provide a D-A converted output of the DISPLAY C measured value (V, A, W, VA, var, PF, deg, Wh, Ah, VHz, or AHz) (Model 2532 □□ / FRQ instruments, only).

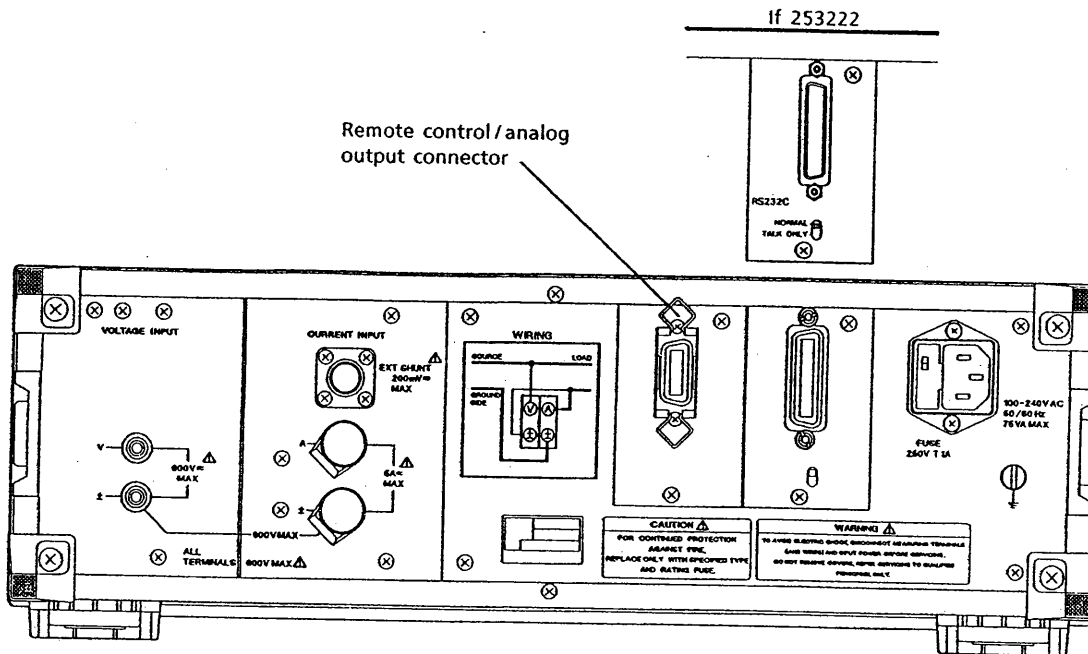

Figure 4.12 Connector Usages

Table 4.13 shows the connector pin numbers.

Table 4.13 Remote Control & Analog Output Pins

Pin No.	Signal Name	Pin No.	Signal Name
1	DIG. COM	8	+5V
2	DIG. COM	9	$\overline{\text{EXT. HOLD}}$
3	$\overline{\text{EXT. START}}$	10	$\overline{\text{EXT. STOP}}$
4	$\overline{\text{EXT. RESET}}$	11	$\overline{\text{EXT. TRIG}}$
5	$\overline{\text{INTEG. BUSY}}$	12	100Hz OUTPUT
6	ANALOG COM*	13	ANALOG COM*
7	DA OUT*	14	N. C.

* : Optional (Model 2532 □□ / FRQ instruments, only)

EXT. START, EXT. STOP, and EXT. RESET signals:

When controlling the Wh and/or Ah integrator functions via these external signals, make sure that the external signal pulse widths are at least 5ms minimum.

4.5.8 Integration Function Communications

See Section 6., "Communications Functions", concerning communications functions for the integrator function.

4.6 Frequency Measurement Function (Optional)

For the Model No. with /FRQ such as 2532□□/FRQ, frequency measurement and D-A output are enabled. The frequency measurement function is described in the following:

Measuring method : Reciprocal method
 Measured signal : Voltage input signal or current input signal
 Display update cycle and measuring range:

Display update cycle	Measuring range
1.6s	2.000Hz ~ 100.00kHz
0.4s	20.00Hz ~ 1000.0kHz

Input signal condition : 10% to 110% of voltage range or current range

Operation method :

- (1) DISPLAY C shows frequency measured-value with FUNCTION set or VHz (frequency measurement of voltage input) or AHz (frequency measurement of current input)
- (2) When input signal level is low or input frequency is smaller than the measuring range, *ErrLo* is displayed to inform the operator of the error status.

When input frequency is higher than the measuring range, *ErrHi* is displayed to inform the operator of the error status.

Caution: For low-frequency signal measurement, it is recommended that FILTER be turned ON to eliminate noise influence.

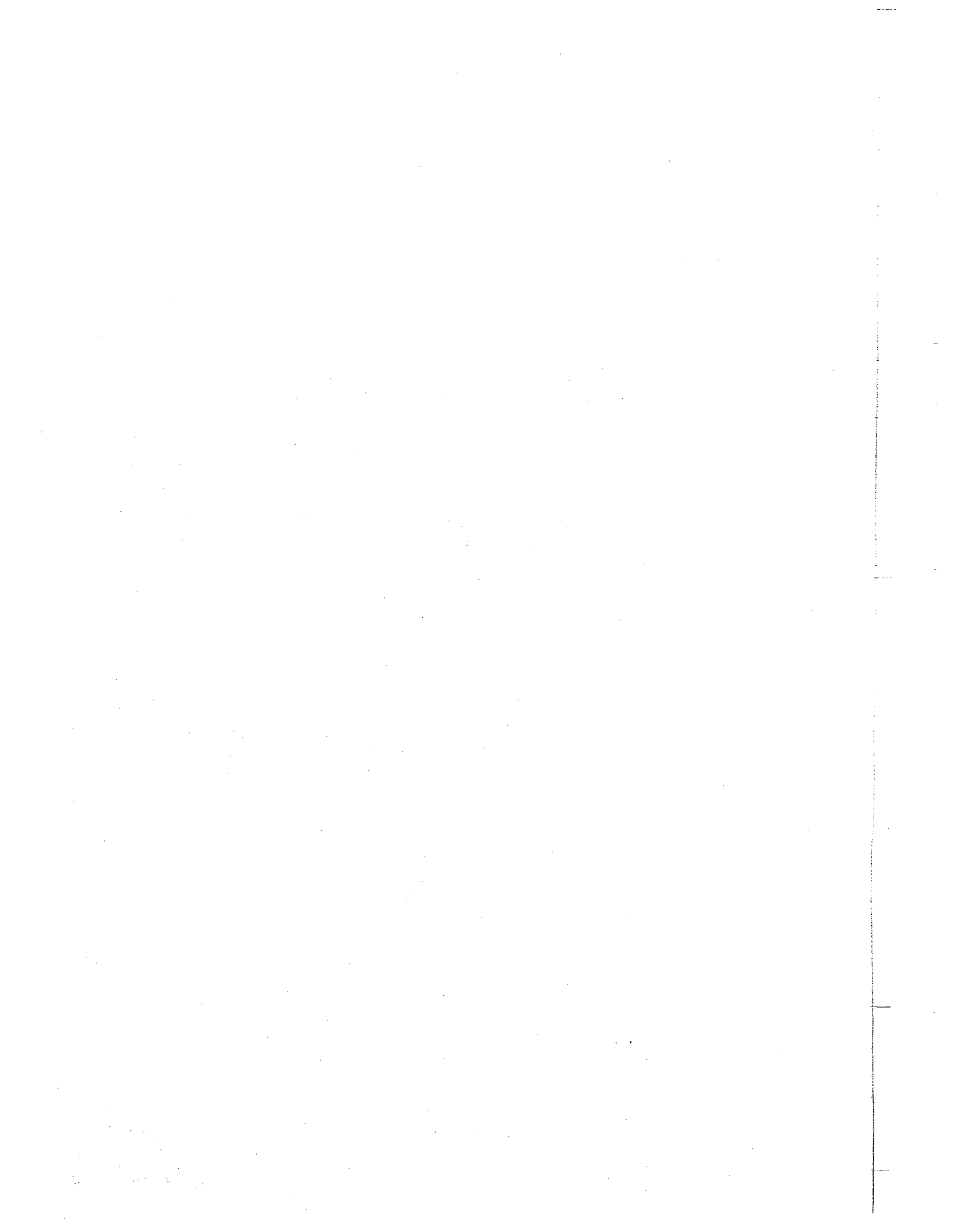

5. INPUT / OUTPUT SIGNALS

The REMOTE CONTROL & ANALOG OUTPUT connector shown in Figure 5.1 can be used to perform the following operations.

- (1) Start display update (SAMPLE) via an external signal;
- (2) Hold display update (SAMPLE) via an external signal;
- (3) Start, stop, or reset integration via an external signal;
- (4) Output an analog signal D-A converted from the display value in DISPLAY C; values can be output for V, A, W, VA, var, PF, deg, Wh, Ah, VHz, or AHz (this is available from Model 2532 □□ / FRQ only (model with frequency measurement and D-A output functions)).

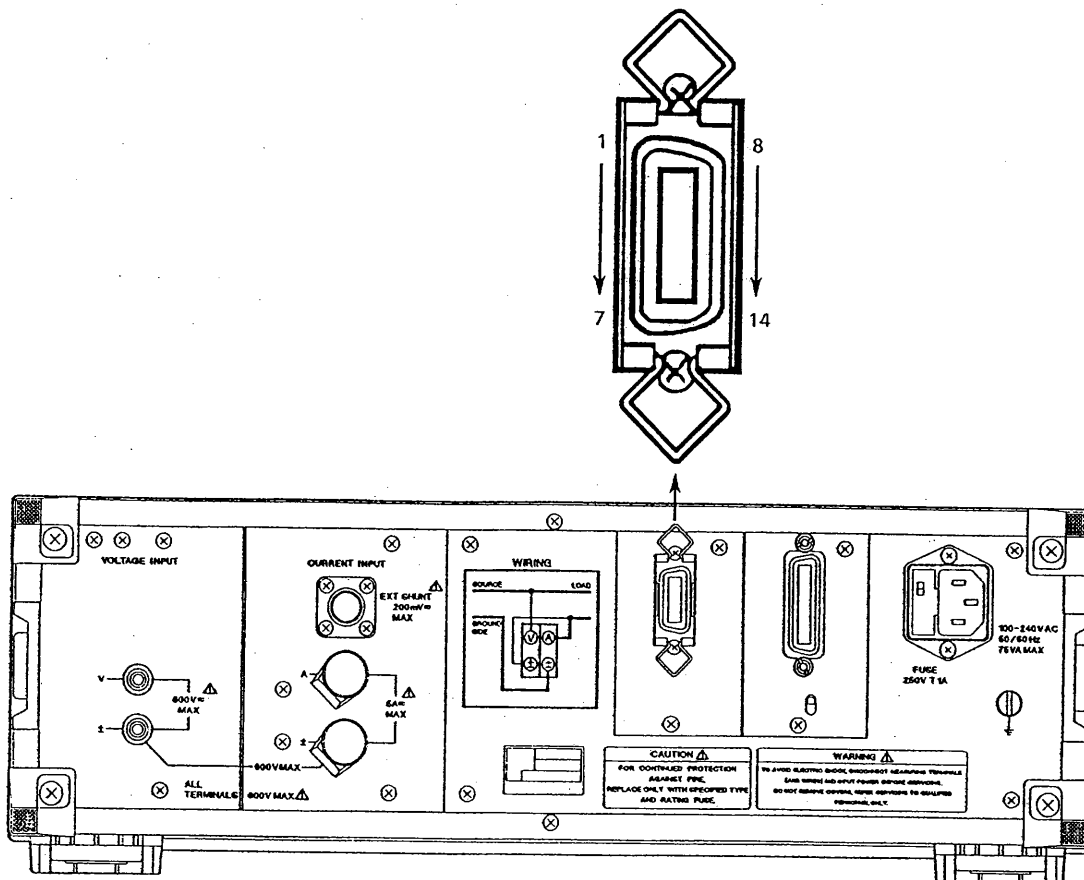

Figure 5.1 Remote Control/Analog Output Connector Location

5.1 Remote Control Signals

5.1.1 Connector Pin Assign and Input/Output Levels

(1) The remote control/analog output connector is an AMPHENOL 57-30140. Signal names and contact pin numbers are given in Table 5.1.

Table 5.1 Signal Names and Pin Numbers

Pin No.	Signal Name	Pin No.	Signal Name
1	DIG. COM	8	+5V
2	DIG. COM	9	$\overline{\text{EXT. HOLD}}$
3	$\overline{\text{EXT. START}}$	10	$\overline{\text{EXT. STOP}}$
4	$\overline{\text{EXT. RESET}}$	11	$\overline{\text{EXT. TRIG}}$
5	$\overline{\text{INTEG. BUSY}}$	12	100Hz OUTPUT
6	ANALOG COM	13	ANALOG COM
7	D-A OUT	14	N. C.

(2) Remote Control Signal Circuit Types and Levels

Table 5.2 shows the circuit type and levels for each signal.

Table 5.2 Remote Control Signal Circuit Types and Levels

Signal Name	Circuit Type	Logic Levels
Remote control signals $\overline{\text{EXT TRIG}}$ $\overline{\text{EXT START}}$ $\overline{\text{EXT STOP}}$ $\overline{\text{EXT RESET}}$ $\overline{\text{EXT HOLD}}$ (Inputs)		TTL levels L : 0V to 0.6V H : 2.4V to 5V
$\overline{\text{INTEG BUSY}}$ 100Hz OUTPUT (Outputs)		TTL levels L : 1mA H : -400μA

5.1.2 Remote Control Function

The table below shows the signal function and signal level pulse width requirements.

Table 5.3 Signal Function and Pulse Width Requirements

Signal Name	Function	Signal Type
$\overline{\text{EXT TRIG}}$	Signal for external start of display update (SAMPLE) (Corresponds to SAMPLE TRIG key)	Detection : Level Pulse width : 5ms or more
$\overline{\text{EXT START}}$ $\overline{\text{EXT STOP}}$ $\overline{\text{EXT RESET}}$	Signal which controls (start / stop / reset) integration action externally. (Corresponding to the START / STOP and RESET keys)	
$\overline{\text{EXT HOLD}}$	Signal which holds display updating externally. (Corresponding to the SAMPLE HOLD key)	

To start display update (SAMPLE) using an external signal, a contact signal or TTL logic signal should be input between connector pin No. 11 and pin No. 1. In the case of a logic signal, the pulse width must be kept to 5ms or more. The diagram below shows a measurement timing chart.

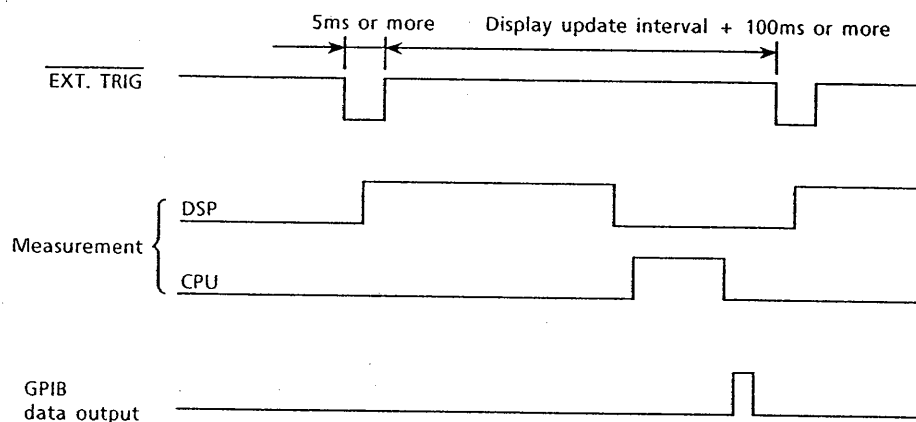

Figure 5.2 Measurement Timing Chart

5.2 D-A (Analog) Output

If the /FRQ function is added as an option, then when the display mode for DISPLAY C is V, A, W, VA, var, PF, deg, Wh, Ah, VHz, or AHZ the corresponding display value will be D-A converted and output as an analog signal through the rear connector. The D-A output update interval is the same as for data display, either 0.4s or 1.6s (1.6s, if FILTER ON in Hz display mode). When sampling is in a hold state, the D-A output is also in a hold state.

Table 5.4 shows the output voltage values for each display mode.

Table 5.4 D-A Output for Each Function

DISPLAY C Display	D-A Output								
V A W var VA	Output as 5V DC at rated range value (for example, for 100V, 5A range combination, rated range values are 100V, 5A, 500W, 500var, and 500VA)								
PF	when PF=1, output is 5V DC (PF=-1 : -5V DC)								
deg	Outputs -5V DC to 0 to +5V DC for display values of $\overset{\curvearrowright}{\cup}$ 180.0 deg to 0 to $\overset{\curvearrowleft}{\cup}$ 180.0 deg. $\overset{\curvearrowright}{\cup}$ indicates lag, and $\overset{\curvearrowleft}{\cup}$ indicates lead.								
Hz	<p>D-A output (V)</p>								
Ah Wh	<table border="1"> <thead> <tr> <th>Resolution for Rated W or A Display</th> <th>Data Output as 5V</th> </tr> </thead> <tbody> <tr> <td>Times 10</td> <td>1 hour rating</td> </tr> <tr> <td>Times 1</td> <td>10 hour rating</td> </tr> <tr> <td>Times 0.1</td> <td>100 hour rating</td> </tr> </tbody> </table>	Resolution for Rated W or A Display	Data Output as 5V	Times 10	1 hour rating	Times 1	10 hour rating	Times 0.1	100 hour rating
Resolution for Rated W or A Display	Data Output as 5V								
Times 10	1 hour rating								
Times 1	10 hour rating								
Times 0.1	100 hour rating								

- Taking the output at rated value as 100%, the D-A output range is $\pm 140\%$.

140% or more	Approx. 7.5V
140%	7.0V
100%	5.0V
0%	0V
-100%	-5.0V
-140%	-7.0V
-140% or less	Approx. -7.5V

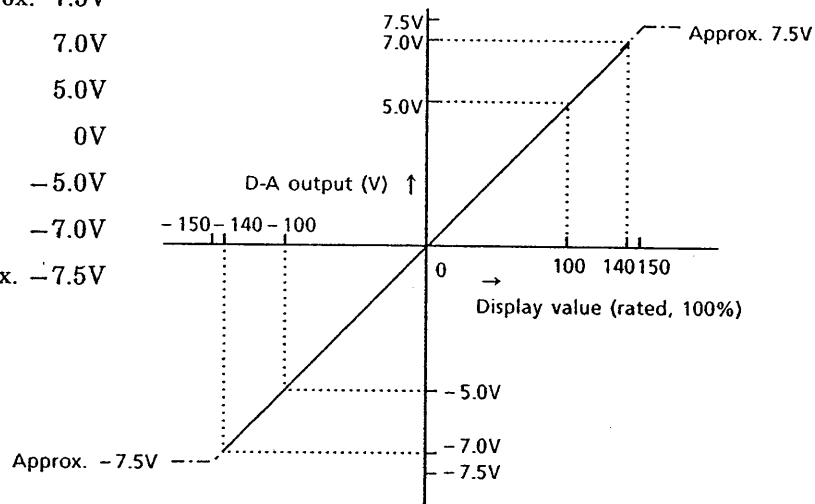

- Approx. +7.5V is output for error output.
- Figure 5.3 and Figure 5.4 show the D-A output timing.
When hold is ON, D-A output continues to correspond to the display. If the display data is updated by a manual start operation, the D-A output is updated at the same time.

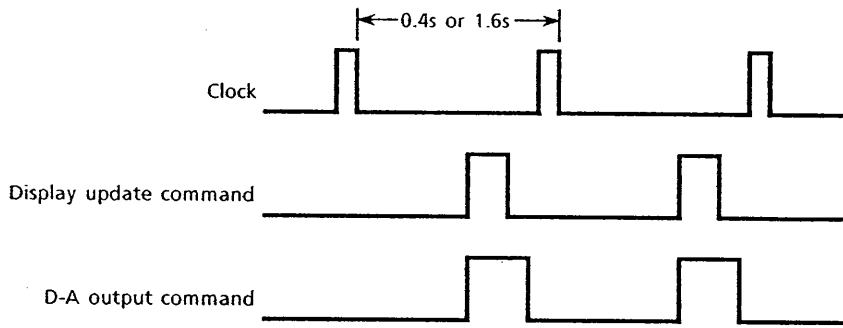

Figure 5.3 With Hold OFF

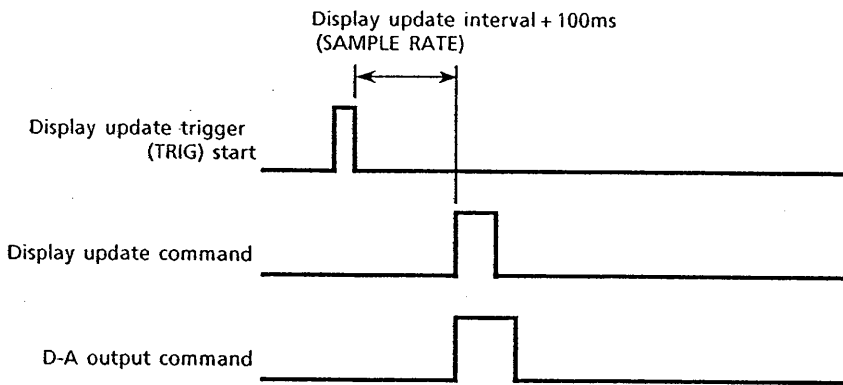
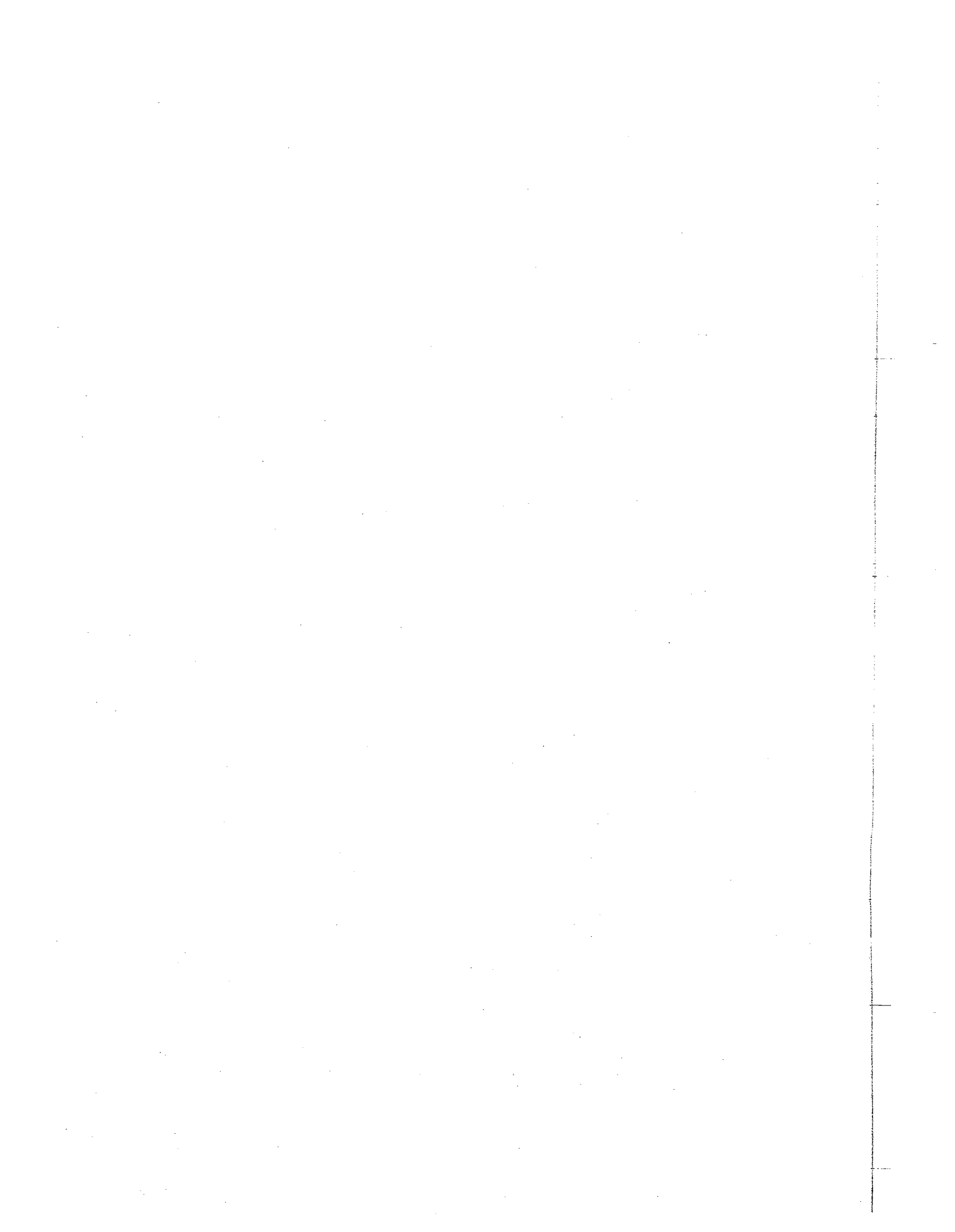

Figure 5.4 With Hold ON



6. COMMUNICATIONS FUNCTIONS

6.1 GPIB Interface (Standard in Model 253221)

6.1.1 Overview

(1) Overview

The 253221 Digital Power Meter is equipped with a GPIB interface for communications functions which permit remote control by a GPIB controller, and support output of a variety of data.

- Operations supported by the GPIB interface.

Table 6.1

Mode	Direction	Function
Addressable mode	Listener	<ul style="list-style-type: none"> • Functions performed using panel operations (excluding the POWER ON/OFF, INTERFACE, and LOCAL keys) <ul style="list-style-type: none"> V, A range selection Display data type selection Measurement mode selection • Parameter setup • Panel setup information output request • Integration value output request • Error code output request • Integration function operation control
	Talker	<ul style="list-style-type: none"> • Measured/computed data output • IC memory card data output • Panel setup information output • Error code output • Status byte output • Integration value output
Talk Only Mode	Talker	<ul style="list-style-type: none"> Measured/computed data output IC memory card data output

(2) Hardware Setup• **Talk Only Mode**

The 2532 can be set to talk only mode using the switch on the rear panel.

• **Address Selection**

The GPIB address is selected using the panel LOCAL, cursor, and ENTER keys.





< GPIB Address Selection Procedure >

Make sure that the instrument is in local status (remote (REMOTE) display LED is off).

① Press the LOCAL key to go to the address setup mode.

Display A, Display B : No display

Display C : **Addr 01** (**01** indicates the address when shipped from the factory)

② Use the cursor keys (, , , ) to select the desired address.

③ Use the ENTER key to enter the selection and return the instrument to normal measurement mode.

(3) Specifications

Electrical and mechanical specifications : Conforms to IEEE St'd 488-1978
 Functional specifications : SH1, AH1, T5, L4, SR1, RL1, PP0, DC1, DT1, C0
 Code set used : ISO (ASCII) code set
 Address setup : Talker/listener addresses from 0 to 30 can be set by panel entry.
 Remote mode clear : Can be cleared by pressing the LOCAL key on the keyboard (disabled when LOCAL LOCK OUT has been set from the GPIB controller)

< Functions >

Table 6.2

FUNCTION	Description
SH1	Full source handshake capability
AH1	Full acceptor handshake capability
T5	Basic talker capability, serial polling, untalk on MLA (My Listen Address), talk-only capability
L4	Basic listener capability, unlisten on MTA (My Talk Address)
SR1	Full service request capability
RL1	Full remote/local capability
PP0	No parallel polling capability
DC1	Full device clear capability
DT1	Full device trigger capability
C0	No controller function

<Response to Interface Messages>

The responses to interface messages are as follows :

- (a) SDC (Selected Device Clear), DCL (Device CLear)
 - Initializes the instrument (except the interface).
- (b) GET (Group Execute Trigger)
 - Starts measurement, when in manual sampling mode.

<To Transfer Between Remote and Local>

- (a) To transfer from local to remote
 - Local panel setup parameters are maintained even if the system is transferred to remote mode.
- (b) To transfer from remote to local
 - Remote panel setup parameters are maintained even if the system is transferred to local mode.

<Command Buffer>

The interface permits multiple command statements in a single line, using the semicolon (“;”) as a separator between command statements. A single line should not exceed 50 characters; any characters beyond the first 50 characters will be ignored.

<Terminators>

Any of the following may be used as a terminator.

- CR+LF
- LF
- Semicolon (“;”)

A terminator + EOI may also be used.

6.1.2 Listener Function

The 2532 permits remote control of all functions that the user can perform through the front panel keys, except for operation of the POWER ON/OFF switch and setup of the communications parameters (GPIB addresses) by INTERFACE LOCAL key. The 2532 can also output its setup information in response to commands received from the controller.

The listener function executes operations prescribed by program data received from the talker (Talker) when the ATN (Attention) signal line is "False".

For the 2532, "program data" consists of ASCII character code strings of the form

[**command**] + [**parameter**] + [**terminator**] .

Note : The [**command**] + [**parameter**] string should not exceed 50 characters in length.

Anything beyond the first 50 characters will be ignored.

- Command : Predefined strings of 1 to 3 capital letters.
 - Parameter : Defined as numeric values (ASCII encoded).
 - Terminator :
 - CR+LF
 - LF
 - EOI
 - Semicolon (";")
- } Any of the following will be accepted.

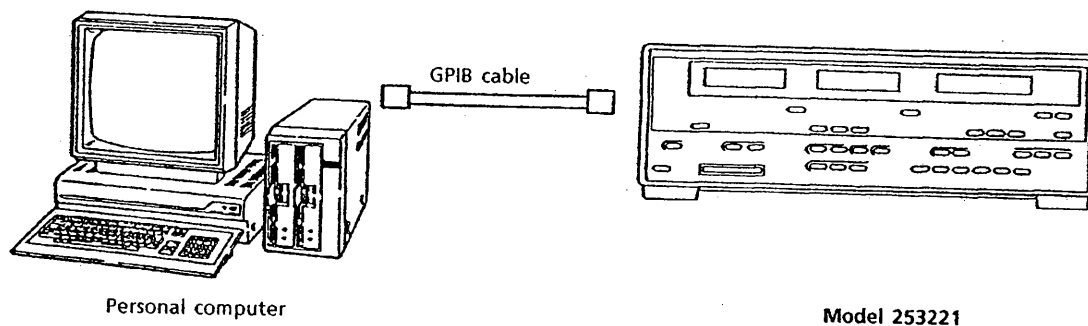

Figure 6.1 Connection Between Computer and 2532 Using GPIB Cable

6.1.3 Talker Function

(1) Talker Function

This function can be used to output measured data and setup information. The talker function can be used to output measured data, panel setup information, integration values, status bytes, and error codes. Measured data can be output in real-time. See (2) in Section 6.1.1 for the address setup procedure.

(2) Measured Data Output Format (␣ indicates a space)

(a) Output Format for Individual Data Items

Header	Data	Terminator
--------	------	------------

• Header

h1	h2	h3	h4	h5	h6
----	----	----	----	----	----

h1~h3 : Data type

V␣ Voltage
 A␣ Current
 W␣ Active power
 VA␣ Apparent power
 Var Reactive power
 PF␣ Power factor
 DEG Phase angle
 Wh␣ Integrated active power (Watt - hour)
 Ah␣ Integrated current (Ampere - hour)
 HzV Frequency (voltage)
 HzA Frequency (current)
 HM␣ Integration time
 MEM Recall data sample number

h4 : "1" if data type is other than HM␣ or MEM.

Space if data type is HM␣ or MEM.

h5 : Data status

If the data type is other than MEM, this indicates one of the following as the data status.

N Normal
 I Overrange
 O Computation overflow

If the data type is MEM, this indicates one of the following as the data status.

N Intermediate data
 E Final (end) data
 P Nth data in N reading mode
 T Single trigger data (generated in response to trigger in recall single mode)
 I Illegal data (generated if memory card is removed during recall)

h6 : Space if data type is other than PF $\bar{_}$ or DEG.

If data type is PF $\bar{_}$ or DEG, indicates the phase - lead or phase - lag detection results.

G LAG (phase - lag)
 D LEAD (phase - lead)
 $\bar{_}$ Detection not possible

• Data

If data type is other than HM $\bar{_}$ or MEM

d1	d2	d3	d4	d5	d6	d7	d8	d9	d10	d11
----	----	----	----	----	----	----	----	----	-----	-----

d1 : Polarity Space (+), -
 d2~d8 : 6-digit numeric value + decimal point
 d9~d11: Exponent E-3 10^{-3} [m]
 E+0 10^0 [1]
 E+3 10^3 [k]
 E+6 10^6 [M]

The following format is used for overrange data.

d1	d2	d3	d4	d5	d6	d7	d8	d9	d10	d11
$\bar{_}$	9	9	9	9	9	9	.	E	+	3

The following format is used for computation overflow data.

d1	d2	d3	d4	d5	d6	d7	d8	d9	d10	d11
$\bar{_}$	8	8	8	8	8	8	.	E	+	0

If the data type is HM $\bar{_}$

d1	d2	d3	d4	d5
----	----	----	----	----

d1~d3 : Integration time "hours", 3-digit numeric value
 d4~d5 : Integration time "minutes", 2-digit numeric value

If the data type is MEM

d1	d2	d3	d4	d5
----	----	----	----	----

d1 : Sign: Space (+), -
 d2~d5 : Recall data No. 4-digit numeric value

- Terminators

CR+LF (+EOI)

LF

EOI

(b) Output Format for Single Data Block

- If the function on Display C is other than Wh or Ah :

For normal data output, the data block contains four lines, for recall data output, it contains five lines.

☆ In the case of a header "MEM" line with "I" (illegal) as the data status, the other lines of recall data output are omitted (the block contains one line only).

M	E	M	┌	N	┌	Data No.	Terminator	Data No., output for recall data only
V	┌	┌	1	N	┌	Data	Terminator	Voltage
A	┌	┌	1	N	┌	Data	Terminator	Current
W	┌	┌	1	N	┌	Data	Terminator	Active power
			1	N	┌	Data	Terminator	Display C data

└──────────┘
Display C function

- If the function on Display C is Wh or Ah :

For normal data output the block contains three lines; for memory data output, it contains four lines.

☆ In the case of a header "MEM" line with "I" (illegal) as the data status, the other lines of recall data output are omitted (the block contains one line only).

M	E	M	┌	N	┌	Data No.	Terminator	Data No., output for recall data only
H	M	┌	┌	N	┌	Data	Terminator	Integration time
W	h	┌	1	N	┌	Data	Terminator	Integrated power value
A	h	┌	1	N	┌	Data	Terminator	Integrated current value

(3) Output Format for Setup Information

Table 6.3

Line	Output information
Line 1	Model (MDL2532)
Line 2	Voltage range Voltage auto range ON/OFF
Line 3	Current range Current auto range ON/OFF External shunt current value
Line 4	Display A function Display B function Display C function
Line 5	EA1 EB1 EC1
Line 6	WR2 Voltage mode (RMS/MEAN) Filter ON/OFF Cut-off frequency User-set cut-off frequency Averaging ON/OFF Scaling ON/OFF Frequency range Sample hold ON/OFF Data update interval
Line 7	Voltage scaling factor Current scaling factor Power scaling factor
Line 8	Integration time
Line 9	INS value Storage rate Storage mode Recall rate Recall mode Recall starting position number

(4) Output Format for Integration Value

The format is the same as the output format for a single data block of normal data.

H	M	_	_	N	_	Integration time	Terminator
W	h	_	1	N	_	Data	Terminator
A	h	_	1	N	_	Data	Terminator

(5) Output Format for Status Byte

bit8	bit7	bit6	bit5	bit4	bit3	bit2	bit1
DIO8	DIO7	DIO6	DIO5	DIO4	DIO3	DIO2	DIO1
Integration BUSY	SRQ	ERROR	Storage/ recall BUSY	OVER	Syntax ERROR	Integration END	Computation END

- DIO8 : "1" while integration is in progress; changes to "0" when integration stops.
- DIO7 : Service request. Set to "1" when any one or more of the status byte interrupt cause bits specified by the IM command (bit 4, 3, 2, 1) changes to "1".
- DIO6 : Set to "1" when an error is generated (when bit 4 or bit 3 changes to "1").
- DIO5 : Set to "1" when data is being stored to a memory card, or when data is being
- DIO4 : Set to "1" in the case of overrange or computation overflow.
- DIO3 : Set to "1" when a command is received via communications and causes a condition classifiable as a "syntax error"; that is, either the command is undefined, or a parameter is outside of the allowed range, or the command cannot be executed by the instrument in the mode currently in effect.
- DIO2 : Set to "1" when a integration time-out occurs in timer mode, or when there is an overflow of integration data in manual mode.
- DIO1 : Set to "1" when measurement or computation is complete.

(6) Output Format for Error Codes



|
Error code, 2 characters

Table 6.4 lists the error codes and their meanings.

Table 6.4 Error Code Table

Error code	Description
11	Command error
12	Parameter error
13	Command received which cannot be executed in the existing mode
51	Measured data overflow
52	Voltage peak overrange
53	Current peak overrange
54	Power factor (PF) function selected, and power factor exceeds 2.
55	Phase angle function selected, and power factor exceeds 2
56	Frequency data overflow
57	Scaling computation overflow
41	Attempted to start integration, in spite of integration data overflow or integration time-out.
42	Attempted to start integration, in spite of integration being in progress, or instrument not being in integration mode
43	Integration stopped due to integration overflow
44	Attempted to stop integration, but integration was not in progress
45	Attempted to reset integration, in spite of integration being still in progress, or instrument not being in integration mode
46	Attempted to start integration, in spite of voltage or current peak overrange having been detected
30	Memory card file data error
31	Memory card not initialized
32	File not on memory card
33	Memory card has no free area
34	Memory card not inserted
35	Memory card failure
36	No recall data
39	Not a 2532 file

6.2 RS-232-C Interface (Standard in Model 253222)

6.2.1 Overview

The RS-232-C interface is an Electronic Industry Association (EIA, US) standard that prescribes specifications for interface between a Data Terminal Equipment (DTE) device and a Data Circuit-terminating Equipment (DCE) device, and which is widely used for communications via telephone circuits.

(1) Overview

The 253222 is equipped with a RS-232-C interface for communications functions, which permit remote control by a personal computer and support output of a variety of data.

- Operations supported by the RS-232-C interface.

Table 6.5

Control	Direction	Function
Normal mode	Receive	<ul style="list-style-type: none"> • Functions performed using panel operations (excluding POWER ON/OFF and RS-232-C MODE) <ul style="list-style-type: none"> V, A range selection Display data type selection Measurement mode selection • Measured data output request • Panel setup information output request • Error code output request • Integrator function operation control
	Transmit	<ul style="list-style-type: none"> • Measured/computed data output • IC memory card data output • Panel setup information output • Error code output • Status byte output • Integration value output
Talk - only mode	Transmit	<ul style="list-style-type: none"> Measured/computed data output IC memory card data output

(2) General Specifications

- Communication : Point-to-point
- Communication : Full-duplex
- Synchronization : Asynchronous (start-stop)
- Communication rate : 75, 150, 300, 600, 1200, 2400, 4800, 9600 bps.
Any one of the above rates can be selected.
- Start bits : 1 bit
Start bit is fixed at 1 bit.
- Data length (word length) : 7 or 8 bits
User can select either 7 bits or 8 bits as the data (word) length
- Parity : User can select even (EVEN), odd (ODD), or no parity.
- Stop bit : 1 or 2 bits
User can select either 1 or 2 stop bits.
- Electrical interface : EIA RS-232-C conformant
- Connector : DBSP-JB25S (JAE) (on rear panel)
Use an interface cable with DB-25P or equivalent connector for mating to the RS-232-C interface connector.
- Hardware handshaking : User can select whether CA, CB, CC, and CD signals will be always TRUE, or will be used for control.
- Software handshaking : User can select whether to control only transmission using X-on and X-off characters, or control both transmission and reception using X-on and X-off characters.
 ◦ X-on.....ASCII 11H ◦ X-off.....ASCII 13H
- Receive buffer size : 64 bytes

6.2.2 Functional Description of the RS-232-C Interface

(1) Connector and Signal Names

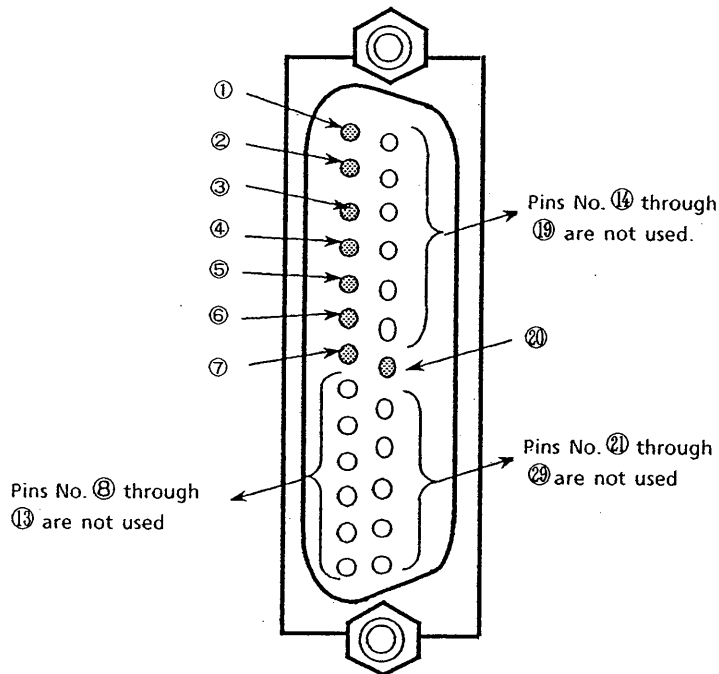

Figure 6.2 RS-232-C Connector (DBSP-JB25S or Equivalent)

Reference : The table below summarizes the signals in the RS-232-C standard, and the abbreviations used for them in the corresponding JIS and CCITT standards.

Table 6.6 RS-232-C Signal Table

Pin number (25-pin connector)	Abbreviations			Name
	RS-232-C	CCITT	JIS	
①	AA (GND)	101	FG	Protective ground
⑦	AB (GND)	102	SG	Signal ground
②	BA (TXD)	103	SD	Transmitted data
③	BB (RXD)	104	RD	Received data
④	CA (RTS)	105	<RS	Request to send
⑤	CB (CTS)	106	CS	Clear to send
⑥	CC (DSR)	107	DR	Data set ready
⑳	CD (DTR)	108/2	ER	Data terminal ready
㉒	CE (RI)	125	CI	Ring indicator
⑧	CF (DCD)	109	CD	Data channel received carrier detector
㉑	CG (—)	110	SQD	Data signal quality detector
㉓	CH/CI (—)	111	SRS	Data signal rate selector
㉔	DA/DB (—)	113/114	ST1/ST2	Transmitter signal element timing
⑰	DD (RXC)	115	RT	Receiver signal element timing
⑭	SBA (—)	118	BSD	Secondary transmitted data
⑮	SBB (—)	119	BRD	Secondary received data
⑱	SCA (—)	120	BRS	Secondary request to send
⑬	SCB (—)	121	BCS	Secondary clear to send
⑫	SCF (—)	122	BCD	Secondary received carrier detector

- ① AA (GND ; Protective Ground) : Grounded to the 2532 case.
- ② BA (TXD ; Transmitted Data) : Data transmitted to personal computer
Signal direction : Output.
- ③ BB (RXD ; Received Data) : Data received from personal computer
Signal direction : Input.
- ④ CA (RTS ; Request to Send) : Signal used to handshake when receiving data from
personal computer signal direction : Output.
- ⑤ CB (CTS ; Clear to Send) : Signal used to handshake when transmitting data
to personal computer signal direction : Input.
- ⑥ CC (DSR ; Data Set Ready) : Signal used to handshake when transmitting data
to personal computer signal direction : Input.
- ⑦ AB (GND ; Signal Ground) : Ground connection for signal.
- ⑧ CD (DTR ; Data Terminal Ready) : Signal used to handshake when receiving data from
personal computer signal direction : Output.

Note : Pins ⑨ through ⑰ and ⑱ through ⑳ are not used.

(2) Handshaking System Combinations

When the 2532 is connected with a personal computer via the RS-232-C interface, some one of a variety of sets of procedures will be implemented by mutual agreement so as to ensure dependable transfers of data. These procedures are based on a technique known as "handshaking." A variety of handshaking systems can be used. The choice must be made according to the personal computer hardware and software used for the interface to the instrument, since the 2532 and the personal computer must be set up to use the same system.

In the 2532 instrument the user can select via the panel keys any of the eight systems shown in Table 6.7.

See (1) in Section 6.2.3 for setup procedures.

Table 6.7

(○ ----- Function used)

Mode selection No.	Transmit (System for control when sending) data control (System for control when sending) data to personal computer				Received (System for control when receiving) data control (System for control when receiving) data from personal computer			
	Software handshake		Hardware handshake		Software handshake		Hardware handshake	
	Stop sending when X - off received, resume when X-on received	Stop sending when CB (CTS) is False, resume when True	Stop sending when CC (DSR) is False, resume when True	No handshake	Send X - off when receive buffer data reaches 3/4 - full, send X - on when buffer reaches 1/4 - full	Set CD (DTR) to False when receive buffer data reaches 3/4 - full, set to True when buffer 1/4 - full	Set CA (RTS) to False when receive buffer data reaches 3/4 - full, set to True when buffer 1/4 - full	No handshake
0				○				○
1	○				○			
2	○					○		
3	○						○	
4		○				○		
5		○					○	
6			○			○		
7			○				○	

(3) Data Control

Even when a data reception control handshake mechanism is in use, data may in some cases still be transmitted from the personal computer despite the handshake mechanism having acted to stop transmission.

If this occurs and the receive buffer becomes full, the excess data will be discarded and lost, regardless of whether handshaking is or is not in use. Data storage to the buffer will begin again when there is free area in the buffer.

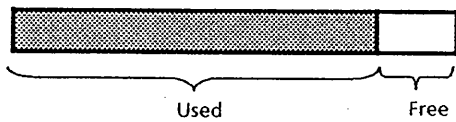

If handshaking is in use, and data cannot be passed to the main program fast enough to keep up with the transmission, then handshaking will attempt to stop transmission when the buffer free area reaches 16 bytes.

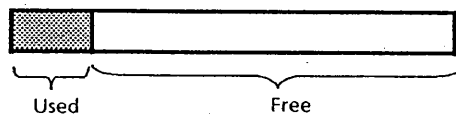

After the above, data continues to be passed to the internal program, and handshaking will allow transmission to resume when the buffer free area reaches 48 bytes.

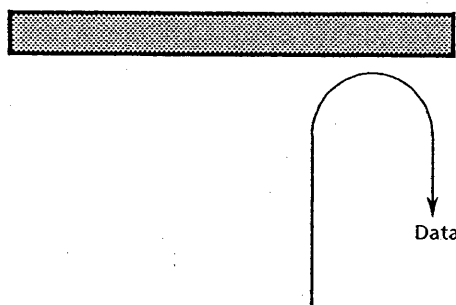

Whether a handshake is performed or not, if the buffer becomes full, data is no longer stored, and is lost.

Figure 6.3 Data Control Configuration Diagram

(4) Data Format for Communications

The internal RS-232-C interface of the 2532 communicates using start - stop synchronization. In start - stop synchronization the devices transmit one character at a time, each character beginning with a start bit, which is followed in sequence by the data bits, a parity bit, and one or two stop bits (see figure below).

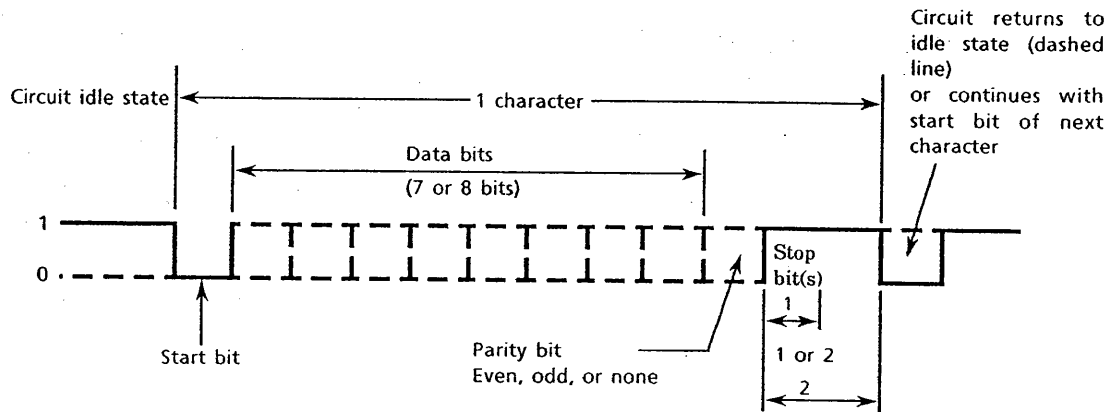

Figure 6.4 Communication Data Format

Table 6.8 Data Format Table

Set value	Start bit	Data length	Parity	Stop bit
0	1	8	None	1
1	1	7	Odd	1
2	1	7	Even	1
3	1	7	None	2

Use the panel INTERFACE key to set up the data format. See (2) in Section 6.2.3 for details.

(5) Connection to a Computer

If connecting this instrument to a computer, use the panel key switches to set the handshake, data transmission rate, data format, etc. to be consistent with those on the computer side.

For details, see (2) in Section 6.2.3. Use an interface cable that meets the specifications for this instrument.

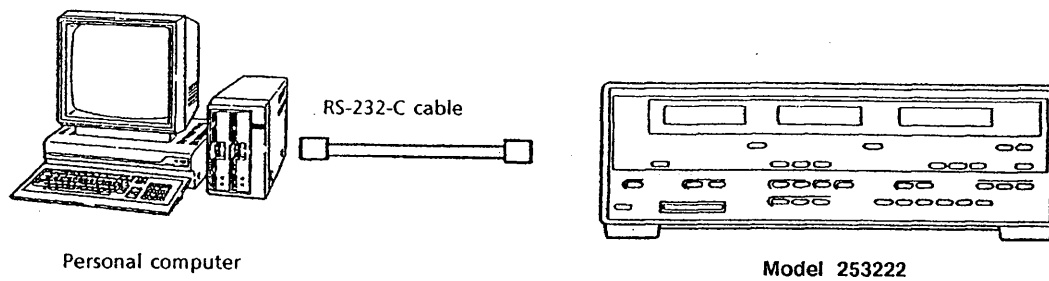
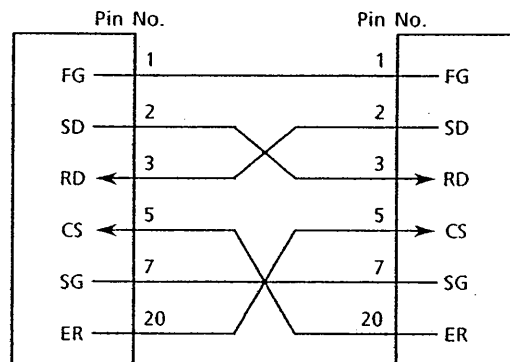

Figure 6.5 Connection Between Computer and this Instrument Using RS-232-C Cable

- Cable Wiring Diagram (Personal Computer and 2532)



Communication mode : 2
Recommended cable : B9801LB

Figure 6.6 RS-232-C Cable Wiring Diagram

6.2.3 Remote Control Functions

The 2532 makes it possible to use remote control for any of those functions that can be performed in normal mode using the panel keys, excluding the "POWER" switch key, and communications setup keys.

(1) General Procedures

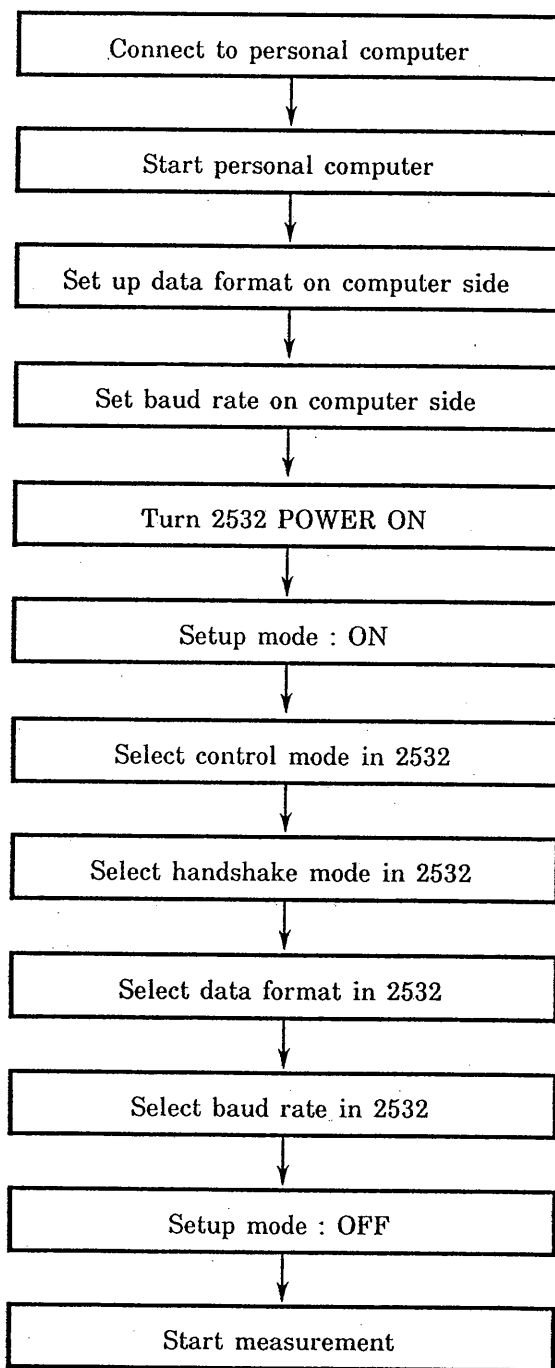

Figure 6.7 General Operating Procedures for Remote Control

(2) RS-232-C Settings

The modes involved in control of the 2532 by means of commands from a personal computer include both setup functions and output functions. The 2532 RS-232-C setup functions can be operated in normal mode, using the panel keys while viewing the display.

For details concerning setup procedures, see Item (2) in Section 3.5.8.

(3) Basic Programming Format

Remote control of this instrument is performed by sending program commands from a personal computer.

The program command data for this instrument is sent as ASCII - encoded character strings representing command + parameter + terminator sequences.

Note : The [command+parameter] string should not exceed 50 characters in length.

Anything beyond the first 50 characters will be ignored.

(Command)	(Parameter)	(Terminator)
RA	m	$\left. \begin{array}{l} \text{CR LF} \\ \text{LF} \\ ; \end{array} \right\}$

- Command : Predefined strings of 1 to 3 capital letters.
- Parameter : Defined as numeric values (ASCII encoded).
- Terminator :
 - CR LF
 - LF
 - Semicolon (“;”) $\left. \vphantom{\begin{array}{l} \circ \\ \circ \\ \circ \end{array}} \right\} \text{Any of the following will be accepted.}$

Note • If the personal computer normally terminates an output line with a CR only (rather than CR + LF), the user should append a semicolon “;” at line end.

6.2.4 Data Output Function

(1) Data Output Function

The 2532 communications functions support output of measured data, panel setup information, integration values, a status byte, and error status codes.

(2) Data Output Format ... Output Using **OD** Command

The output format is the same as for the GPIB interface.
See (2) in Section 6.1.3.

(3) Panel Setup Information Output Format

Reception of an **OS** command causes the panel setup information to be output. Output sequence and contents are the same as for the GPIB interface. See (3) in Section 6.1.3.

(4) Integration Value Format

Reception of an **OI** command causes the integration value to be output, when integration has ended. Output sequence and contents are the same as for the GPIB interface. See (4) in Section 6.1.3.

(5) Status Byte Output Format

Reception of the **ESC S** command causes the status byte to be output. The status byte format is as follows.

bit8	bit7	bit6	bit5	bit4	bit3	bit2	bit1
DIO8	DIO7	DIO6	DIO5	DIO4	DIO3	DIO2	DIO1
Integration BUSY	1	ERROR	Store/recall BUSY	OVER	Syntax ERROR	Integration END	Computation END

- DIO8 : "1" while integration is in progress; "0" when integration is stopped.
- DIO7 : Always "1".
- DIO6 : Set to "1" when an error is generated (when bit 4 or bit 3 changes to "1").
- DIO5 : Set to "1" when data is being stored to a memory card, or when data is being recalled from a memory card.
- DIO4 : Set to "1" in the case of overrange or computation overflow.
- DIO3 : Set to "1" when a command is received via communications and causes a condition classifiable as a "syntax error"; that is, either the command is undefined, or a parameter is outside of the allowed range, or the command cannot be executed by the instrument in the mode currently in effect.
- DIO2 : Set to "1" when a integration time - out occurs in timer mode, or when there is an overflow of integration data in manual mode.
- DIO1 : Set to "1" when measurement or computation is complete.

(6) Error Code Output Format ... Output Using "OC" Command



Error code, 2 characters

Table 6.9 lists the error codes and their meanings.

Table 6.9 Error Code Table

Error code	Description
11	Command error
12	Parameter error
13	Command received which cannot be executed in existing mode
51	Measured data overflow
52	Voltage peak overrange
53	Current peak overrange
54	Power factor (PF) function selected, and power factor exceeds 2.
55	Phase angle function selected, and power factor exceeds 2
56	Frequency data overflow
57	Scaling computation overflow
41	Attempted to start integration, in spite of integration data overflow or integration time - out.
42	Attempted to start integration, in spite of integration being in progress, or instrument not being in integration mode
43	Integration stopped due to integration overflow
44	Attempted to stop integration, but integration was not in progress
45	Attempted to reset integration, in spite of integration being still in progress, or instrument not being in integration mode
46	Attempted to start integration, in spite of voltage peak overrange having been detected
30	Memory card file data error
31	Memory card not initialized
32	File not on memory card
33	Memory card has no free area
34	Memory card not inserted
35	Memory card failure
36	No recall data
39	Not a 2532 file

6.3 Communications Commands

6.3.1 GPIB Command Summary Table (For 253221)

Table 6.10 GPIB Command Summary Table

Program data		Action	
Measurement/ display	Function range	AVm Auto Voltage range	Sets function range
		AAm Auto current(A) range	
		RVm set Range Voltage	
		RAm set Range current (A)	
	Display	DAm set Display A function	Selects display
		DBm set Display B function	
DCm set Display C function			
Functions	Filter	FLm set FiLter	Sets filter
		FCm set Frequency Cut off	Selects cutoff frequency (standard value)
		FUm set Frequency User	Selects cutoff frequency (user-set value)
	RMS value	MNm MeaN	Selects computational formula for RMS value (RMS/MEAN)
	Frequency	FRm set Frequency Range	Selects frequency range
	Integration	ISm Integrate Start/stop	Starts/stops integration
		IR Integrate Reset	Resets integration
		TMh, m set integrate TiMer	Selects integration function and sets integration time
		OI Output Integrate data	Requests output of integration value, if integration has ended
	Data update (Sampling)	HDm sampling Hold	Holds measurement
		E/ST trigger <GET>	Generates trigger
		SIm set Data update Interval	Sets sampling rate
	Averaging	AGm AveraGing	Turns averaging ON/OFF
	Scaling	SCm SCaling	Turns scaling ON/OFF
		KAm K×Ampare	Sets scaling factor
		KVm K×Voltage	
		KWm K×Wattage	
	Shunt	SAM set Shunt current (A)	Sets shunt current value
	IC memory card	SRm Store Rate	Selects store rate
		SMm Store Mode	Selects store mode
		RRm Recall Rate	Selects recall rate
		RMm Recall Mode	Selects recall mode
		NSm set NS	Sets NS value
		RDm Recall Data	Sets data recall starting position
		SS panel Setting Save	Writes panel setup information
		SL panel Setting Load	Reads panel setup information
		CI Card Initialize	Initializes IC memory card
		SOM Store On	Writes data to IC memory card
	ROM Recall On	Reads data from IC memory card	
	Other	Output	OS Output panel Setting
OE Output Error code			Requests output of error code
Control		IMm Interrupt Mask	Sets status byte interrupt cause mask
		DLm DeLimiter	Selects delimiter
		RC Reset Command	Initializes panel setup information

6.3.2 RS-232-C Command Summary Table (For 253222)

Table 6.11 RS-232-C Command Summary Table

Program data		Action		
Measurement/display	Function range	AVm Auto Voltage range	Sets function range	
		AAm Auto current (A) range		
		RVm set Range Voltage		
		RAm set Range current (A)		
	Display	DAm set Display A function	Selects display	
		DBm set Display B function		
DCm set Display C function				
Functions	Filter	FLm set FiLter	Sets filter	
		FCm set Frequency Cut off	Selects cutoff frequency (standard value)	
		FUm set Frequency User	Selects cutoff frequency (user-set value)	
	RMS value	MNm MeaN	Selects computational formula for RMS value (RMS/MEAN)	
	Frequency	FRm set Frequency Range	Selects frequency range	
	Integration	ISm Integrate Start/stop	Starts/stops integration	
		IR Integrate Reset	Resets integration	
		TMh, m set integrate TiMer	Selects integration function and sets integration time	
		OI Output Integrate data	Requests output of integration value, if integration has ended	
	Dta update (Sampling)	HDm sampling HoLD	Holds measurement	
		E/ST Trigger	Generates trigger	
		SIm set Data update Interval	Sets sampling rate	
	Averaging	AGm AveraGing	Turns averaging ON/OFF	
	Scaling	SCm SCaling	Turns scaling ON/OFF	
		KAm K×Ampare	Sets scaling factor	
		KVm K×Voltage		
		KWm K×Wattage		
	Shunt	SAm set Shunt current (A)	Sets shunt current value	
	IC memory card	SRm Store Rate	Selects store rate	
		SMm Store Mode	Selects store mode	
		RRm Recall Rate	Selects recall rate	
		RMm Recall Mode	Selects recall mode	
		NSm set NS	Sets NS value	
		RDm Recall Data	Sets data recall starting position	
		SS panel Setting Save	Writes panel setup information	
		SL panel Setting Load	Reads panel setup information	
		CI Card Initialize	Initializes IC memory card	
		SOm Store On	Writes data to IC memory card	
		ROm Recall On	Reads data from IC memory card	
		Other	Output	OS Output panel Setting
OE Output Error code				Requests output of error code
OD Output Data	Requests output of measured data or of data from IC memory card			
<ESC> S	Requests output of status byte			
IMm Interrupt Mask	Sets status byte interrupt cause mask			
Control	DLm DeLimiter		Selects delimiter	
	RC Reset Command		Initializes panel setup information	
	<ESC> L		Selects local control	
	<ESC> R		Selects remote control	
	<ESC> C		Clears device	

6.3.3 Communication Command Descriptions

(1) Function Range Setup

AV (Auto Voltage range)

AA (Auto current (A) range)

Function	Selects whether the voltage/current range will be automatically selected or fixed.
----------	--

Syntax	AV m <terminator> AA m <terminator> m=0, 1
--------	--

Description	<ul style="list-style-type: none"> • m=0 is fixed range mode. The AUTO key LED lamp is OFF. • m=1 is auto range selection mode. The AUTO key LED lamp is ON. • If "m" is not specified, or has a value of 2 or more, this is treated as a syntax error and ignored, and range mode remains unchanged (error code 12). • The initialized value is m = 0. If battery back-up is used, the value set for local mode is used as the initial value. • These functions are equivalent to operations of the range AUTO key in local mode. • These functions cannot be used while in integration mode, or while recall is in progress; they will generate error code 13 (illegal parameter error).
-------------	--

RV (Range Voltage)

Function	Selects the voltage range in manual range mode.
Syntax	RV m <terminator> m=2 to 9
Description	<ul style="list-style-type: none"> • “m” is assigned as follows. The lamp for the selected voltage range will turn on. <ul style="list-style-type: none"> RV 2 10V range RV 3 15V range RV 4 30V range RV 5 60V range RV 6 100V range RV 7 150V range RV 8 300V range RV 9 600V range • If “m” is “0”, “1”, or “10” or more, this is treated as a syntax error and “m” is ignored, the range remains unchanged (error code 12). • These functions are equivalent to operations of the VOLTAGE RANGE (V) range up/down keys in local mode. • These functions cannot be used while in integration mode, or while recall is in progress, they will generate error code 13 (illegal parameter error).

RA (Range current (A))

Function	Selects the current range in manual range mode.
Syntax	RA m <terminator> m=0 to 7, 15 to 17
Description	<ul style="list-style-type: none"> • “m” is assigned as follows. The lamp for the selected current range will turn on. <ul style="list-style-type: none"> RA 0 20mA RA 1 50mA RA 2 100mA RA 3 200mA RA 4 500mA RA 5 1A RA 6 2A RA 7 5A RA 15 50mV RA 16 100mV RA 17 200mV • If “m” is any value other than “0” to “7” or “15” to “17”, this is treated as a syntax error and “m” is ignored; the range remains unchanged (error code 12). • These functions are equivalent to operations of the CURRENT RANGE (A) range up/down keys in local mode. • Initial value : 7 (5A) • These functions cannot be used while in integration mode, or while recall is in progress, they will generate error code 13 (illegal parameter error).

(2) Display A, B, C Function Selection
DA, DB, DC (Display A, B, C function)

Function Selects the function for Display A, Display B, or Display C.

Syntax DA m <terminator> m=1 to 3
 DB m <terminator> m=1 to 3
 DC m <terminator> m=1 to 11

Description • "m" is assigned as follows.

Parameter "m"	Program data DA m, DB m	Program data DC m
1	V (voltage) display	V (voltage) display
2	A (current) display	A (current) display
3	W (active power) display	W (active power) display
4	_____	var (reactive power) display
5	_____	VA (apparent power) display
6	_____	PF (power factor) display
7	_____	VHz (voltage frequency) display
8	_____	AHz (current frequency) display
9	_____	Wh (integrated power) display
10	_____	Ah (integrated current) display
11	_____	deg (phase angle) display

- Initial values: DA1, DB2, DC3
- These functions are equivalent, individually, to operations of the FUNCTION keys for DISPLAY A, DISPLAY B, and DISPLAY C.
- Only the command for DISPLAY C is prohibited during recall from an IC memory card (it will generate error code 13).
- When in integration mode, transfers between integration mode and other modes is not possible during store operations.

(3) Filter Setup**FL (Set L. P. F)**

Function	Selects whether or not a low-pass filter is used.
Syntax	LF m <terminator> m=0, 1
Description	<ul style="list-style-type: none"> • "m" is assigned as follows. <ul style="list-style-type: none"> FL 0 Low-pass filter not used FL 1 Low-pass filter used • Initial value: "0" (low-pass filter not used) • This function is equivalent to the filter ON/OFF key. • These functions cannot be used while in integration mode, or while recall is in progress; they will generate error code 13.

FC (Frequency Cut off)

Function	Selects the cut off frequency of the low-pass filter (from among the standard values).
Syntax	FC m <terminator> $4 \leq m \leq 7$
Description	<ul style="list-style-type: none"> • "m" is assigned as follows <ul style="list-style-type: none"> FC 4 250Hz FC 5 500Hz FC 6 1000Hz FC 7 2000Hz • If "m" is outside of its valid range, this is treated as a syntax error and "m" is ignored, the cutoff selection remains unchanged. This generates error code 12. • This function is equivalent to the operation of the FILTER fc key and up (\wedge) and down (\vee) keys in local mode. • Initial value : 7 (2000Hz) • These functions cannot be used while in integration mode, or while recall is in progress; they will generate error code 13.

FU (Freq. USER)

Function	Sets the cut off frequency of the low-pass filter (user-set value).
Syntax	FU m <terminator> m=250 to 2000
Description	<ul style="list-style-type: none"> • "m" is an integer from 250 to 2000, units are Hz. • These functions are equivalent to operations of the FILTER fc key and up (\wedge) and down (\vee) keys in local mode, or to the operation of the cursor keys (\wedge , \vee , \lt , and \gt) when USER is selected. • These functions cannot be used while in integration mode, or while recall is in progress; they will generate error code 13.

RMS value computation method selection

MN (Mean)

Function	Selects either true rms effective value (TRUE RMS) computation, or rms-calibrated average rectified value (MEAN) computation.
Syntax	MN m <terminator> m=0, 1
Description	<ul style="list-style-type: none"> • “m” is assigned as follows. <ul style="list-style-type: none"> MN 0TRUE RMS (RMS/MEAN key RMS lamp is on) MN 1MEAN • “m” is omitted, or has a value of 2 or more, this is treated as a syntax error, and the selection remains unchanged. This generates error code 12. • These functions are equivalent to operations of the MODE RMS/MEAN key in local mode. • Initial value : 0 (RMS) • These functions cannot be used while in integration mode, or while recall is in progress; they will generate error code 13.

Frequency range selection

FR (Frequency Range)

Function	Sets the frequency range.
Syntax	FR m <terminator> m=1 to 3
Description	<ul style="list-style-type: none"> • “m” is assigned as follows. <ul style="list-style-type: none"> FR 1 LO (DC, 20Hz to 10kHz) FR 2 MID (DC, 200Hz to 80kHz) FR 3 HI (DC, 2kHz to 400kHz) • Initial value : 1 • This is equivalent to the FREQ RANGE key. • These functions cannot be used while in integration mode, or while recall is in progress; they will generate error code 13.

Averaging function selection

AG (Averaging)

Function	Selects whether or not to perform exponential averaging on voltage, current, and power measurement.
Syntax	AG m <terminator>
Description	<ul style="list-style-type: none"> • “m” is assigned as follows. <ul style="list-style-type: none"> AG 0 Exponential averaging is not performed. AVG key lamp is off. AG 1 Exponential averaging is performed. AVG key lamp is on. • These functions are equivalent to operations of the AVG key in local mode. • Initial value : 0

Integration function operation control

IS (Integrate Start/stop)

Function	Integration function start command.
Syntax	IS m <terminator> m=0, 1
Description	<ul style="list-style-type: none"> • If m=0, the integration function stops, and the START / STOP key lamp turns off. • If m=1, the integration function starts, and the START / STOP key lamp turns on. • This command is equivalent to operations of the INTEGRATOR START / STOP key in local mode. If start is attempted after a data overflow or time-out has occurred, error code 41 is generated. If start is attempted after a peak overvoltage or overcurrent has occurred, error code 46 is generated. If start is attempted when not in integration mode, or when integration is already in progress, error code 42 is generated. If stop is attempted when integration is not in progress, error code 44 is generated. If start is attempted while recall from the memory card is in progress, error code 13 is generated.

IR (Integrate Reset)

Function	Integration function reset command.
Syntax	IR <terminator>
Description	<ul style="list-style-type: none"> • These functions are equivalent to operations of the INTEGRATOR RESET key in local mode. • This command is not accepted while recall is in progress; it will generate error code 13. If these functions are executed while integration is in progress, or in a mode other than integration mode, error code 45 is generated.

TM (set integrate TiMer)

Function	Selects manual mode or timer mode, and sets the integration time for timer mode.
Syntax	TM h, m <terminator> $0 \leq m \leq 59$ $0 \leq h \leq 100$ h, m 0,0 to 100,0 h : Hours, m : Minutes
Description	<ul style="list-style-type: none"> • If the time that is set is outside of the permitted range for “h” and/or “m”, or is over 100hours, this is treated as a syntax error. • This command is not accepted in integration mode, or when store or recall with the memory card is in progress; it will generate error code 13. • Initial value is 0,0.

OI (Output Integrate data)

Function	Causes integration value to be output when integration has been stopped.
Syntax	OI <terminator>
Description	<ul style="list-style-type: none"> • If the OI command is received while integration is stopped, the integration value is output. • Data cannot be read while integration is in progress (function is ignored, no error is output).

Sampling mode operation control

HD (sampling Hold)

Function	Selects whether display data is put on hold, or whether hold is off.
Syntax	HD m <terminator> m=0, 1
Description	<ul style="list-style-type: none"> • If m=0, the hold-off mode key lamp turns off. • If m=1, the hold mode key lamp turns on. • If "m" is omitted or is 2 or more, this is treated as a syntax error, and the selection remains unchanged; this generates error code 12. • These functions are equivalent to operations of the MODE HOLD key in local mode. • If m=1 when in integration mode, data output (display) stops. • This command is not accepted while store or recall with the IC memory card is in progress; it will generate error code 13. • Initial value is 0 (hold off).

E or ST

Function	Generates a trigger.
Syntax	E <terminator>, ST <terminator> Or, GET <interface message>
Description	<ul style="list-style-type: none"> • If this command is received when display update (SAMPLE) is on hold, measurement is performed once, the data display is updated, and that data is output. • If data is being stored to the IC memory card in memory mode, this sets a trigger point. • For N reading store/recall, this starts the operation. In cases where this is not possible, the command is ignored, but no syntax error results. • These functions are equivalent to operations of the TRIG key in local mode.

SI (Sampling Interval)

Function	Selects the display update interval (SAMPLE RATE).
Syntax	SI m <terminator> m=1, 2
Description	<ul style="list-style-type: none"> • “m” is assigned as follows. <ul style="list-style-type: none"> SI 1 Display update interval, 0.4s SI 2 Display update interval, 1.6s • If “m” is omitted, or has a value greater than 2, this is treated as a syntax error, and the selection remains unchanged; this will generate error code 12. • These functions are equivalent to operations of the MODE SAMPLE RATE key in local mode (0.4s/1.6s). • This command is not accepted in integration mode, or while store or recall with the IC memory card is in progress; it will generate error code 13. • Initial value of “m” is 2 (1.6s).

Scaling function operation control SC (SCaling)

Function	Selects whether to display the measured value (SCALING OFF), or to display the product of the measured value and the scaling factor (SCALING ON).
Syntax	SC m <terminator> m=0, 1
Description	<ul style="list-style-type: none"> • “m” is assigned as follows. SC 0 SCALING OFF SC 1 SCALING ON key lamp turns on • If “m” is omitted, or has a value of 2 or more, this is treated as a syntax error, and the selection remains unchanged, this will generate error code 12. • These functions are equivalent to operations of the mode scaling key in local mode. • Initial value of “m” is 0.

KA (K × Ampere) KV (K × Voltage) KW (K × Wattage)

Function	Sets the scaling factor for the voltage, current, or power measured value.
Syntax	KA m <terminator> KV m <terminator> KW m <terminator>
Description	<ul style="list-style-type: none"> • The valid range for the scaling factor is 0.0001 to 10000, where “m” is a floating point or integer number. • If the value of “m” is outside of the permitted range, this is treated as a syntax error, and the factor remains unchanged, this will generate error code 12. • These functions are equivalent to the operations of the SCALING DATA key and up/down keys in local mode. • Initial value: 1.0000, for all • This command is not accepted in integration mode, it will generate error code 13.

SA (Set shunt Current (A))

Function	Sets the shunt current value.
Syntax	SA m <terminator> $0.02 \leq m \leq 100$ (A)
Description	<ul style="list-style-type: none"> • “m” is a floating point or integer number. • If the value of “m” is outside of the permitted range, this is treated as a syntax error, and the factor remains unchanged, this will generate error code 12. • This is equivalent to the scaling data setup operations for an external shunt. • Initial value: 10.0000 (A) • This command is not accepted in integration mode, or when recall is in progress from the IC memory card, it will generate error code 13.

IC memory card operation control SS (panel Setting Save)

Function	Stores current panel key setup to the IC memory card.
Syntax	SS <terminator>
Description	<ul style="list-style-type: none"> • This function is equivalent to the CARD key setup item "SS" in local mode. • The following information is saved. <ul style="list-style-type: none"> Model code Voltage range (V range) Current range (A range, external shunt) Display function (DisplayA, DisplayB, DisplayC) Measurement mode (RMS/MEAN, low-pass filter cutoff frequency, scaling ON / OFF, averaging ON / OFF, frequency range, hold ON / OFF, display update interval) Scaling factor Integration time Card (store rate, recall rate, store mode, recall mode, NS value, recall starting position number) • This command is not accepted in integration mode, or while store or recall with the IC memory card is in progress. This generates error code 13.

SL (panel Setting Load)

Function	Reads the panel key setup previously stored to the IC memory card.
Syntax	SL <terminator>
Description	<ul style="list-style-type: none"> • This function is equivalent to the CARD key setup item "SL" in local mode. • The information that can be read is the same as that written using the "SS" command. • This command is not accepted in integration mode, or while store or recall with the IC memory card is in progress, it will generate error code 13.

CI (Card Initialize)

Function	Initializes the IC memory card.
Syntax	CI <terminator>
Description	<ul style="list-style-type: none"> • This function is equivalent to the CARD key setup item "CI" in local mode. • This command is not accepted in integration mode, or while store or recall with the IC memory card is in progress, it will generate error code 13.

SO (Store On)

Function Selects ON/OFF to specify whether or not measured data is to be stored to the IC memory card.

Syntax SO m <terminator> m=0, 1

Description

- “m” is assigned as follows.

Command	Program data (SO m)
STORE OFF	SO 0
STORE ON	SO 1

- This function is equivalent to store key operations in local mode.
- For STORE ON, the key lamp turns on.

SR (Store Rate)

Function Selects the store rate when store is on.

Syntax SR m <terminator> m=3 to 12 Display update interval,
0.4s (other than integration mode)
m=4 to 12 Display update interval,
1.6s (other than integration mode)
m=4 to 12 In integration mode

Description

- “m” is assigned as follows.

Parameter “m”	Store rate		
	Other than integration mode		Integration mode
	Display update interval, 0.4s	Display update interval, 1.6s	
3	400ms		
4	1.2s	1.6s	1s
5	4s	4.8s	4s
6	10s	9.6s	10s
7	30s	30.4s	30s
8	60s	60.8s	60s
9	300s	272s	300s
10	600s	600s	600s
11	1800s	1800s	1800s
12	3600s	3600s	3600s

- If “m” is omitted, or has a value of 2 or less (3 or less in integration mode, or when display update interval is 1.6s), this is treated as a syntax error, and the selection remains unchanged, this will generate error code 12.
- These functions are equivalent to the store rate setup operations in local mode.
- Initial value: 4
- This command is not accepted while store or recall with the IC memory card is in progress, it will generate error code 13.

SM set (Store mode)

Function	Selects the store mode.
Syntax	SM m <terminator> m = 1 to 2
Description	<ul style="list-style-type: none"> • “m” is assigned as follows. <ul style="list-style-type: none"> SM 1: Auto mode SM 2: N reading mode • Initial value: 1 • This command is not accepted while store or recall with the IC memory card is in progress, it will generate error code 13. • These functions are equivalent to the store mode setup operations in local mode.

NS (Set NS)

Function	In auto mode, sets the pretrigger count; in single mode, sets the preset count; in N reading mode, sets the number of data samples stored for 1 trigger. For recall in N reading mode, sets the number of data samples recalled for 1 trigger.															
Syntax	NS m <terminator> $0 \leq m \leq 3800$															
Description	<ul style="list-style-type: none"> • The valid ranges for “m” are as follows. <table style="margin-left: 40px; border-collapse: collapse;"> <thead> <tr> <th style="text-align: left; padding-right: 10px;">Memory capacity (bytes)</th> <th style="text-align: left; padding-right: 10px;">Other than integration mode</th> <th style="text-align: left;">Integration mode</th> </tr> </thead> <tbody> <tr> <td style="padding-right: 10px;">8K</td> <td style="padding-right: 10px;">1 to 200</td> <td>1 to 360</td> </tr> <tr> <td style="padding-right: 10px;">16K</td> <td style="padding-right: 10px;">1 to 500</td> <td>1 to 900</td> </tr> <tr> <td style="padding-right: 10px;">32K</td> <td style="padding-right: 10px;">1 to 1000</td> <td>1 to 1700</td> </tr> <tr> <td style="padding-right: 10px;">64K</td> <td style="padding-right: 10px;">1 to 2000</td> <td>1 to 3800</td> </tr> </tbody> </table> • If “m” exceeds the permitted maximum value, that maximum value is used for the operation. • If “m” is negative, or greater than 3800, this is treated as a syntax error, and generates error code 12. • This command is not accepted while store or recall with the IC memory card is in progress, it will generate error code 13. • These functions are equivalent to the NS setup operations in local mode. 	Memory capacity (bytes)	Other than integration mode	Integration mode	8K	1 to 200	1 to 360	16K	1 to 500	1 to 900	32K	1 to 1000	1 to 1700	64K	1 to 2000	1 to 3800
Memory capacity (bytes)	Other than integration mode	Integration mode														
8K	1 to 200	1 to 360														
16K	1 to 500	1 to 900														
32K	1 to 1000	1 to 1700														
64K	1 to 2000	1 to 3800														

RO (Recall On)

Function

Selects ON / OFF to specify whether or not to read data from the IC memory card.

Syntax

RO m <terminator> m=0, 1

Description

- "m" is assigned as follows.

Command	Program data (RO m)
RECALL OFF	RO 0
RECALL ON	RO 1

- These functions are equivalent to RECALL key operations in local mode.
- When recall is ON, key lamp turns on.

RR (Recall Rate)

Function

Selects the recall rate applying when recall is on.

Syntax

R m <terminator> m=1 to 5

Description

- "m" is assigned as follows.

Parameter "m"	Recall rate
1	0.1s
2	0.2s
3	0.4s
4	1.2s
5	4s

- If "m" is omitted, or has a value of 6 or more, this is treated as a syntax error, and the selection remains unchanged, this will generate error code 12.
- These functions are equivalent to the recall rate setup operations in local mode.
- Initial value : 1
- This command is not accepted while store or recall with the IC memory card is in progress, it will generate error code 13.

RM (set Recall Mode)

Function

Selects the recall mode.

Syntax

RM m <terminator> m=1 to 2

Description

- "m" is assigned as follows :
 RM 1 : Auto mode
 RM 2 : N reading mode
- These functions are equivalent to the recall mode setup operations in local mode.
- Initial value : 1
- This command is not accepted while store or recall with the IC memory card is in progress, it will generate error code 13.

RD (set Recall Data)

Function	Sets the data sample number for the store data recall start position.															
Syntax	RD m <terminator> m = -3799 to 3799															
Description	<ul style="list-style-type: none"> • The valid ranges for "m" are as follows. <table data-bbox="447 480 1257 634"> <thead> <tr> <th data-bbox="447 480 690 508">Memory capacity (bytes)</th> <th data-bbox="707 480 1053 508">Modes other than integration mode</th> <th data-bbox="1087 480 1257 508">Integration mode</th> </tr> </thead> <tbody> <tr> <td data-bbox="546 512 591 540">8K</td> <td data-bbox="806 512 954 540">-199 to 199</td> <td data-bbox="1103 512 1252 540">-359 to 359</td> </tr> <tr> <td data-bbox="541 544 596 572">16K</td> <td data-bbox="806 544 954 572">-499 to 499</td> <td data-bbox="1103 544 1252 572">-899 to 899</td> </tr> <tr> <td data-bbox="541 576 596 604">32K</td> <td data-bbox="806 576 954 604">-999 to 999</td> <td data-bbox="1087 576 1268 604">-1699 to 1699</td> </tr> <tr> <td data-bbox="541 608 596 636">64K</td> <td data-bbox="794 608 966 636">-1999 to 1999</td> <td data-bbox="1087 608 1268 636">-3799 to 3799</td> </tr> </tbody> </table> • If "m" is greater than 3800, or less than -3800, this is treated as a syntax error, and generates error code 12. • The functions are equivalent to the store data recall start position setup operations in local mode. • This command is not accepted while store or recall with the IC memory card is in progress, it will generate error code 13. 	Memory capacity (bytes)	Modes other than integration mode	Integration mode	8K	-199 to 199	-359 to 359	16K	-499 to 499	-899 to 899	32K	-999 to 999	-1699 to 1699	64K	-1999 to 1999	-3799 to 3799
Memory capacity (bytes)	Modes other than integration mode	Integration mode														
8K	-199 to 199	-359 to 359														
16K	-499 to 499	-899 to 899														
32K	-999 to 999	-1699 to 1699														
64K	-1999 to 1999	-3799 to 3799														

Other

OS (Output panel Setting)

Function	Requests output of the setup information.
Syntax	OS <terminator>
Description	<ul style="list-style-type: none"> • Reception of the OS command causes the setup information to be output. <p>After setup information output is completed, the instrument returns to the measured/computed data output mode.</p>

OE (Output Error code)

Function	Requests output of the error code number.
Syntax	OE <terminator>
Description	<ul style="list-style-type: none"> • Reception of the OE command causes the error number to be output. <p>After error information output is completed, the instrument returns to the measured/computed data output mode.</p> <ul style="list-style-type: none"> • If no error has been generated, error code 00 is output. • For information concerning error codes, see Table 6.4 in (6) of Section 6.1.3, and Table 6.9, "Error Code Table", in (6) of Section 6.2.4.

OD (Output Data) * For RS-232-C only

Function	Requests output of the measured data, or of data from the IC memory card.
Syntax	OD <terminator>
Description	<ul style="list-style-type: none"> • The 2532 outputs the measured / computed data, or data from the IC memory card (see output formats).

IM (Interrupt Mask)

Function Specifies those interrupt causes that will be allowed to generate a status byte interrupt.

Syntax IM m <terminator> m=1 to 15

- Description**
- “m” is assigned as follows.
 - m=1: Interrupt is generated at completion of measurement / computation.
 - m=2: Interrupt is generated for the integration function at time-out (in timer mode), or upon display overflow (in manual mode).
 - m=4: Interrupt is generated by syntax error.
 - If more than one of these causes is to be allowed to generate an interrupt, “m” is set to the sum of the applicable values above.
Example : m=3 Interrupts are generated by integration end and by computation end (1+2).
 - Initial value is m=15.
 - If “m” is omitted, these bits and the SRQ bit (DIO7) will not change to “1”, even if one of these interrupt causes occurs. (This applies for GPIB interface only.)
 - The status byte is automatically cleared after it has been read by serial polling.
 - Integration BUSY and store / recall BUSY cannot be disabled (masked) by this command.

Status byte output format

DIO 8	DIO 7	DIO 6	DIO 5	DIO 4	DIO 3	DIO 2	DIO 1
Integration BUSY	SRQ*	ERROR	Store/ recal BUSY	OVER	Syntax ERROR	Integration END	Computation END
				8	4	2	1

* DIO 7 is always “1” for the RS-232-C interface.

RC (Reset Command)

Function Forcibly initializes the panel setup information (excluding the interface function setup), regardless of the current setup.

Syntax RC <terminator>

- Description**
- This function is equivalent to the panel setup information initialize operation in local mode.

DL (DeLimiter)

Function

Sets the terminator for the output data.

Syntax

DL m <terminator> m=0, 1, 2

Description

- "m" is assigned as follow.

m	GPIB	RS-232C
0	CR, LF+EOI	CR, LF
1	LF	LF
2	EOI	CR

The following commands apply to the RS-232-C interface only.

<ESC> S

Function Requests output of the status byte.

Syntax <ESC> S <ESC> =1BH

Description

- Reception of this command causes the status byte to be output.

<ESC> R

Function Sets the 2532 to remote mode.

Syntax <ESC> R <ESC> =1BH

Description

- When the 2532 is set to remote mode, setup cannot be performed from the panel. Pressing the INTERFACE LOCAL key cancels the remote mode, and sets the instrument to local mode, enabling setup from the panel.

<ESC> L

Function Transfers the 2532 from remote mode to local mode.

Syntax <ESC> L <ESC> =1BH

Description

- When the 2532 is set to local mode, setup can be performed from the panel.
- This function is equivalent to the INTERFACE LOCAL key operation in remote mode.

<ESC> C

Function Device clear

Syntax <ESC> C <ESC> =1BH

Description

- This function sets the instrument to the same status as that to which it is initialized when power is turned ON.

6.4 Sample Program

6.4.1 Function Range Setup

```

110 OPEN "COM1:1200,N,8,1,DS0,CS0,LF" AS #1
120 LF$=CHR$(&HA)
130 PRINT #1,"DA1DB2DC3"
140 PRINT #1,"OS"
150 LINE INPUT #1,D$
155 IF LEFT$(D$,1)=LF$ THEN D$=MID$(D$,2)
160 PRINT D$
170 IF LEFT$(D$,2)<>"NS" THEN GOTO 150
180 END

```

6.4.2 Display A, B, C Function Selection

```

110 OPEN "COM1:1200,N,8,1,DS0,CS0,LF" AS #1
120 LF$=CHR$(&HA)
130 PRINT #1,"RA0"
140 PRINT #1,"OS"
150 LINE INPUT #1,D$
155 IF LEFT$(D$,1)=LF$ THEN D$=MID$(D$,2)
160 PRINT D$
170 IF LEFT$(D$,2)<>"NS" THEN GOTO 150
180 END

```

6.4.3 Integration Function Operation Control

```

110 OPEN "COM1:1200,N,8,1,DS0,CS0,LF" AS #1
120 LF$=CHR$(&HA)
130 PRINT #1,"DC9"
140 INPUT "INTEG START";Y$
150 PRINT #1,"IS1"
155 IF LEFT$(D$,1)=LF$ THEN D$=MID$(D$,2)
160 INPUT "INTEG STOP";Y$
170 PRINT #1,"IS0"
180 '
190 PRINT #1,"OI"
200 LINE INPUT #1,O$
205 IF LEFT$(O$,1)=LF$ THEN O$=MID$(O$,2)
210 PRINT O$
220 IF LEFT$(O$,3)<>"Ah" THEN GOTO 200
230 END

```

6.4.4 Sapmling Mode Operation Control

```
110 OPEN "COM1:1200,N,8,1,DS0,CS0,LF" AS #1
120 LF$=CHR$(&HA)
130 INPUT "HOLD ON (ret)";Y$
140 PRINT #1,"HD1"
150 INPUT "ST (ret)";Y$
160 PRINT #1,"ST"
170 PRINT #1,"OD"
180 LINE INPUT #1,D$
185 IF LEFT$(D$,1)=LF$ THEN D$=MID$(D$,2)
190 PRINT D$
200 LINE INPUT #1,D$
205 IF LEFT$(D$,1)=LF$ THEN D$=MID$(D$,2)
210 PRINT D$
220 LINE INPUT #1,D$
225 IF LEFT$(D$,1)=LF$ THEN D$=MID$(D$,2)
230 PRINT D$
240 LINE INPUT #1,D$
245 IF LEFT$(D$,1)=LF$ THEN D$=MID$(D$,2)
250 PRINT D$
260 END
```

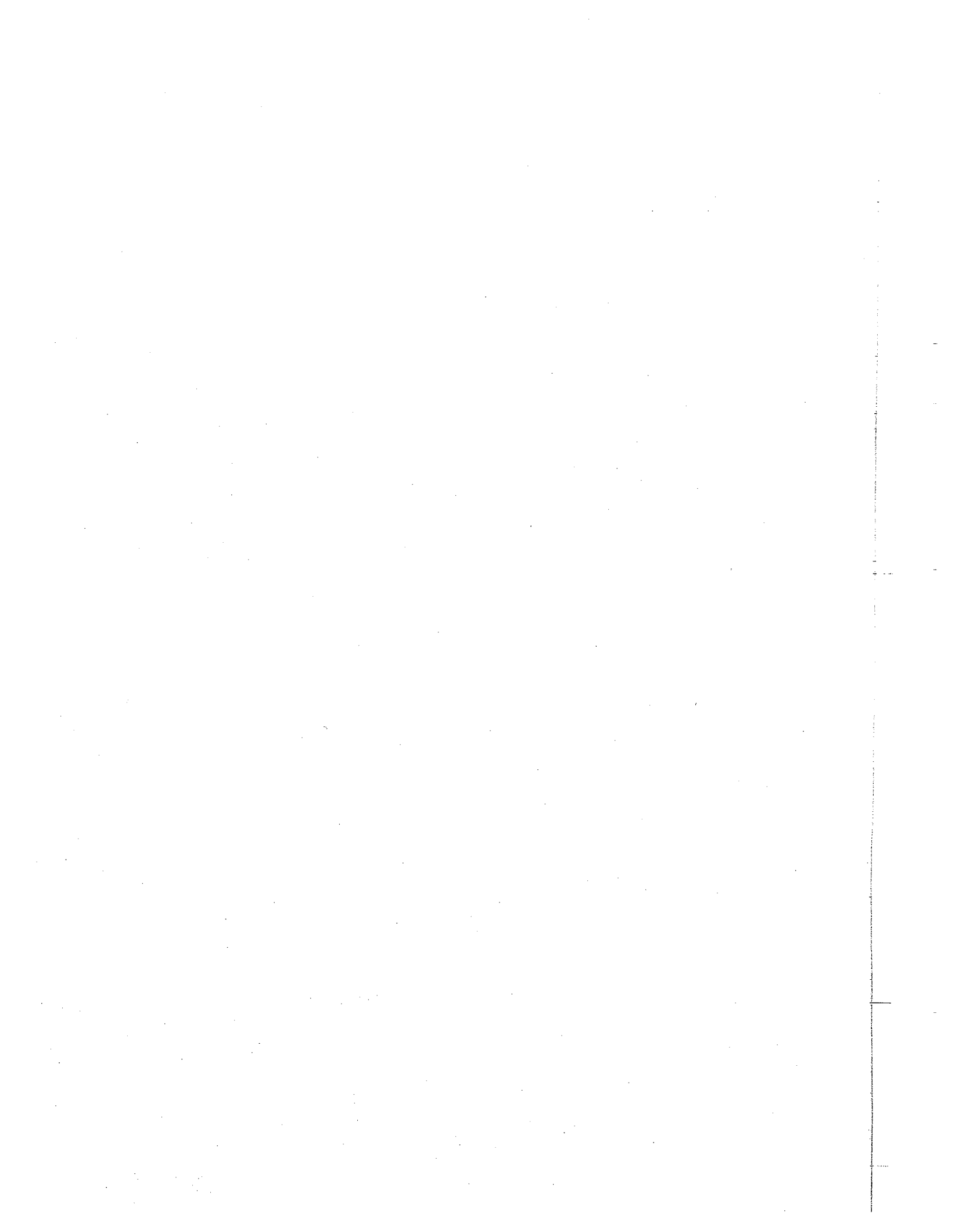

7. MAINTENANCE

7.1 Storage

When storing the instrument, avoid...

- Excessive humidity
- Direct sunlight, and high temperatures
- Locations near high - temperature heat sources
- Severe mechanical vibration
- Locations exposed to high levels of dust, dirt, corrosive gasses, or salt

7.2 Adjustment, Calibration, and Repair

In the event of any of the following, contact YOKOGAWA. Addresses may be found on the back cover of this manual.

- The instrument does not operate normally, requiring repair.
- Adjustment or calibration is needed.

7.3 Fuse Replacement

■ Rear Fuse

If the power supply fuse blows, replace it with the spare 1A time-lag fuse supplied with the accessories (Depends on the suffix code referred to on page 1-4, for both 100V and 200V power voltage systems).

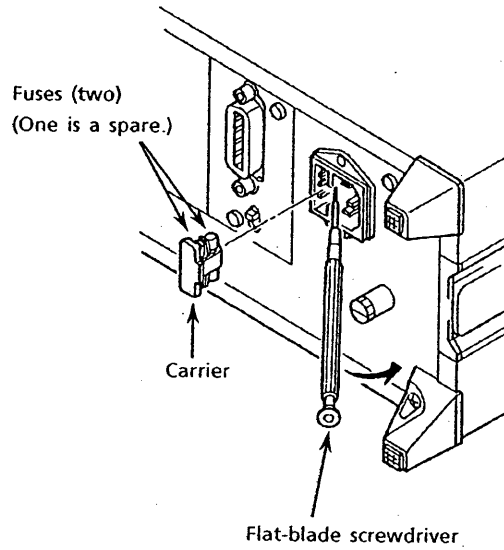

Figure 7.1 Fuse Replacement

To replace the fuse, remove the power cord from the power outlet, and use a flat-blade screwdriver, etc. to remove the carrier. The carrier can hold one spare fuse.

7.4 Panel Setup Information Backup Battery

A panel setup information backup battery is provided on the printed circuit board inside the 2532, to back up the functions, ranges, and other setup information when power is lost, or the power switch is turned OFF.

Under normal usage, the life of the battery is approximately five years.

(1) Charging the Battery

The self-test that is performed when power is turned on (ON) checks the voltage of the panel setup information backup battery.

If the battery voltage is below the rated value, panel setup information will be lost when power is turned OFF; if this has occurred, error code 60 (**Err 60**) is displayed on DISPLAY C, after which display of the opening messages will continue.

Whenever power is ON, the 2532 will charge the panel setup information backup battery. If error code 60 is displayed, leave power on for at least 24 hours to fully charge the battery.

If the battery is sufficiently charged, panel setup information will be protected for up to approximately three months with 2532 power OFF.

(2) Replacing the Battery





















If error code 60 (**Err 60**) is displayed by the power-ON self-test even though the battery has been charged, the battery has reached the end of its life, and must be replaced.

To have the battery replaced, contact YOKOGAWA or YOKOGAWA's sales representative.

(3) Setup Information Backed Up by the Battery

Table 7.1 shows the setup information that is backed up by the panel setup information back-up battery.

Table 7.1

Item	Panel display	Description	
Display mode	V A W 	DISPLAY A setup parameters	
	V A W 	DISPLAY B setup parameters	
	V A W VA VbF PF   deg Wh Ah VHz AHZ	DISPLAY C setup parameters	
Display mode		Selected mode (RMS/MEAN)	
	 SCALING  FILTER 	Individual modes (ON/OFF)	
Display update	 	Selected mode (ON/OFF)	
Measurement range	 10 15 30 60 100 150 300 600 PEAK OVER	Selected range	
		Selected mode (ON/OFF)	
	 20 50 100 200 500 1 2 5 PEAK OVER 50 100 200 EXT SMART mV	Selected range	
		Selected mode (ON/OFF)	
Scaling value	DISPLAY A		PT ratio setting
	DISPLAY B		CT ratio setting, shunt current setting
	DISPLAY C		SCALING FACTOR setting
Timer time		Timer setting	
Filter		Filter setup	
Memory card	MEM CARD   	Setup information (store mode, recall mode, NS value, recall start position data No., store rate, recall rate)	
Interface	 LOCAL	Setup information (GPIB interface, or RS-232-C interface mode)	

Note 1 : Display modes VHz and AHZ for DISPLAY C are valid only when the frequency measurement function (option suffix code /FRQ) is added as an option.

Note 2 : The following parameters associated with the GPIB or RS-232-C interface are not backed up:

- Service request mask : IM**
- Output data terminator : DL* (GPIB only)

8. REFERENCE INFORMATION

The following table shows error codes that are generated during panel operations, at power - ON, and during measurement.

Summary of Panel Operation Error Messages	
Error code	Description
Err 12	Parameter set value outside of range (Scaling, fc, nS, rd)
Err 13	Key operation protected by instrument mode <ul style="list-style-type: none"> • Attempted to operate key protected prior to reset in integration mode • IC memory card: Attempted key operation prohibited while store is in progress • IC memory card: Attempted key operation prohibited while recall is in progress
Err 30	Error in IC memory card file data
Err 31	IC memory card is not initialized (During panel setup information save/store)
Err 32	IC memory card has'nt a file (During panel setup information load/recall)
Err 33	No free area on IC memory card
Err 34	IC memory card not inserted
Err 35	IC memory card failure
Err 36	No recall data
Err 39	Not a 2532 file
Err 41	Attempted to start integration, in spite of integration data overflow or integration time-out.
Err 42	Attempted to start integration, in spite of instrument not being in integration mode
Err 45	Attempted to reset integration in spite of integration still in progress; instrument not in integration mode, or DISPLAY C function in mode other than Wh or Ah.
Err 46	Attempted to start integration, in spite of voltage or current peak overrange having been detected

Summary of Power - ON Test Function Error Messages	
Error code	Description
<i>Err50</i>	Failure in voltage or current input section, or DSP
<i>Err60</i>	Low voltage in panel setup information backup battery. Or, memory contents damaged or lost.
<i>Err61</i> <i>Err64</i> <i>Err65</i> <i>Err66</i>	} Calibration data storage memory failure
<i>Err70</i>	GPIB interface failure
<i>Err71</i>	RS-232-C interface failure
<i>Err80</i>	CPU RAM (memory) failure
<i>Err81</i>	Failure in data exchange with voltage input DMAC, or DMAC failure
<i>Err84</i>	Failure in data exchange with current input DMAC, or DMAC failure
<i>Err87</i>	Failure in data exchange with DSP, or DSP failure
<i>Err90</i>	DIP switch setting error (Change in switch whose manipulation is prohibited.)
<i>Err91</i>	Communications interface (GPIB or RS-232-C) not installed

Summary of Measurement Error Messages	
Error code	Description
<i>--oF--</i>	Computation overflow
<i>--oL--</i>	Input exceeds rated value.
<i>ErrLo</i>	Input level too low in frequency measurement mode, or input frequency outside of measurement range (below lower limit)
<i>ErrHi</i>	Input frequency for frequency measurement outside of measurement range (above upper limit)
<i>PFErr</i>	Power factor computation result exceeded 2.000
<i>dEEErr</i>	Power factor computation result exceeded 2.000 during phase angle measurement

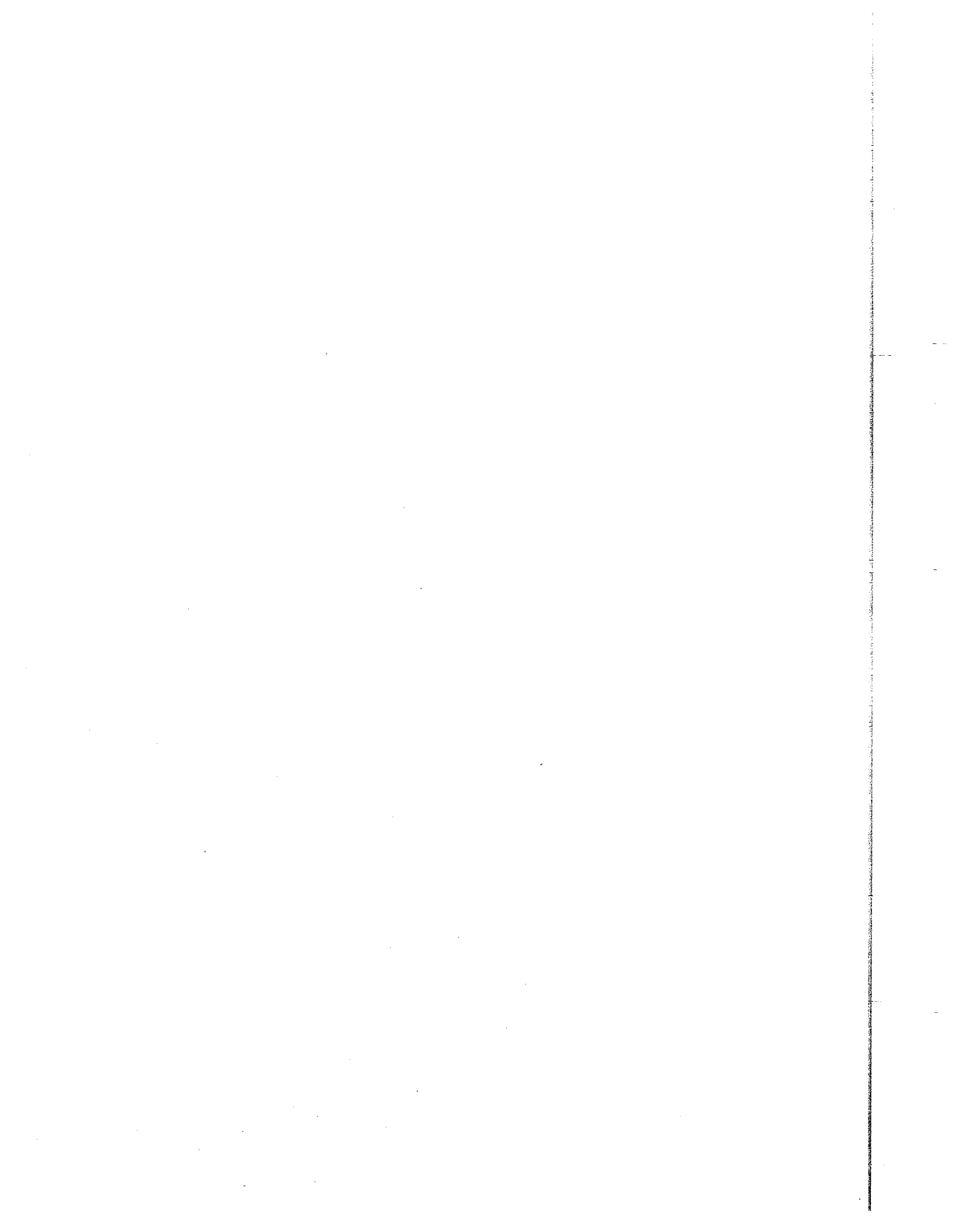

YOKOGAWA

YOKOGAWA ELECTRIC CORPORATION

Headquarters

2-9-32, Nakacho, Musashino-shi, Tokyo, 180 JAPAN

Tokyo Office

Shinjuku Center Bldg. (50F)

1-25-1, Nishi-shinjuku, Shinjuku-ku, Tokyo, 163-06 JAPAN

Fax : 81-3-3348-3705

Telex : J27584 YEW TOK

Branch Sales Offices

Nagoya, Osaka, Hiroshima, Fukuoka, Sapporo, Sendai, Ichihara, Toyoda, Kanazawa, Takamatsu, Okayama, and Kitakyusyu.

Overseas Representative Offices / Service Centers

Beijing, Shanghai (The People's Republic of China), Jakarta (Indonesia)

Kuala Lumpur (Malaysia), Bangkok (Thailand)

YOKOGAWA CORPORATION OF AMERICA

Headquarters

2 Dart Road, Newnan, Ga. 30265-1094, U.S.A.

Phone : 1-770-253-7000

Fax : 1-770-251-2088

Branch Sales Offices / Chagrin Falls, Elk Grove Village, Santa Fe Springs, Colorado, Houston, San Jose

JOHNSON YOKOGAWA CORPORATION

Headquarters

4 Dart Road, Newnan, Ga. 30265-1040, U.S.A.

Phone : 1-770-254-0400 Fax : 1-770-254-0928

Branch Sales Offices / Carrollton, Norwalk, Winter Park, Houston, Philadelphia, Greenwood, Bartlesville, Aurora

YOKOGAWA EUROPE B. V.

Headquarters

Radiumweg 30, 3812 RA, Amersfoort, THE NETHERLANDS

Phone : 31-334-64-1611 Fax : 31-334-63-1202

Telex : 79118 YEF NL

Branch Sales Offices / Maarssen (Netherlands), Wien (Austria), Zaventem (Belgium), Ratingen (Germany), Madrid (Spain), Bratislava (Slovakia), Runcom (United Kingdom), Milano (Italy)

YOKOGAWA ELECTRICA DO BRASIL IND. E COM. LTDA.

Praca Acapulco, No.31, Parque Industrial Jurubatuba, CEP 04675-190 Santo

Amaro, Sao Paulo, SP, BRAZIL

Phone : 55-11-548-2666 Telex : 38-1157755 YOKO BR

Fax : 55-11-522-5231

YOKOGAWA ELECTRIC ASIA PTE. LTD.

Head Office

11 Tampines Street 92, Singapore 528872, SINGAPORE

Phone : 65-783-9537 Fax : 65-786-2606

Telex : RS-26137 YASSIN

HANKUK YOKOGAWA ELECTRIC CO., LTD.

Head Office

K.P.O.Box : 1481, Korean Reinsurance Bldg. 2F,

80 Susong-Dong, Chongro-ku, Seoul, KOREA

Phone : 82-2-3701-0630 / 0650 Fax : 82-2-739-3987

YOKOGAWA AUSTRALIA PTY. LTD.

Head Office (Sydney)

Private mail bag 24, Centre Court D3, 25-27 Paul Street North, North Ryde,

N.S.W.2113, AUSTRALIA

Phone : 61-2-805-0699 Fax : 61-2-888-1844

YOKOGAWA BLUE STAR LTD.

Head Office

40 / 4 Lavelle Road, Bangalore 560 001, INDIA

Phone : 91-80-2271513 Fax : 91-80-2274270

Telex : 81-8458702 YBCO IN

YOKOGAWA CONTROLE BAILEY S. A.

Headquarters

Velizy Valley 18-20, Rue Grange Dame Rose 78140, VELIZY VILLACOUBLAY,

FRANCE

Phone : 33-1-39-26-1000 Fax : 33-1-39-26-1030